

Jetstream® CPX-1000 Release Notes

Release 3.2

Document Number 1000-A2-GK41-20
March 2003

Introduction

Release 3.2 is a major release for the CPX-1000.

This release note identifies the new features and describes known and resolved issues.

New in Release 3.2

CPX-1000 Release 3.2 supports the following:

- 12 port E1 PSTN interface with integrated compression.
- Support for 2000 IADs.
- Support for 2000 simultaneous calls with six 12 port E1 cards.
- 16 V5.2/V5.1 Interface Groups
 - 2000 ports per Interface Group
 - 16000 ports per chassis
- Scheduled database backup.
- Fax/modem auto-detection.
- Dynamic Echo Cancellation and Compression for POTs and ISDN.

New Components in Release 3.2

Component
Release 3.2 Software
3.2 Software Upgrade Kit
JetCraft Software 3.2
JetVision Windows Software 3.2
JetVision Solaris Software 3.2
JetVision Client Software 3.2
12 port E1 ECAC

New CPX-1000 PDU

Some models of the CPX-1000 are shipping with a different type of PDU than the one shown in the user documentation.

The new PDU contains two plunger-type circuit breakers instead of one double-pole switch. To remove power from the PDU, pull each circuit breaker plunger out. To apply power to the PDU, push each circuit breaker plunger completely in and release.

The new PDU is shown below.

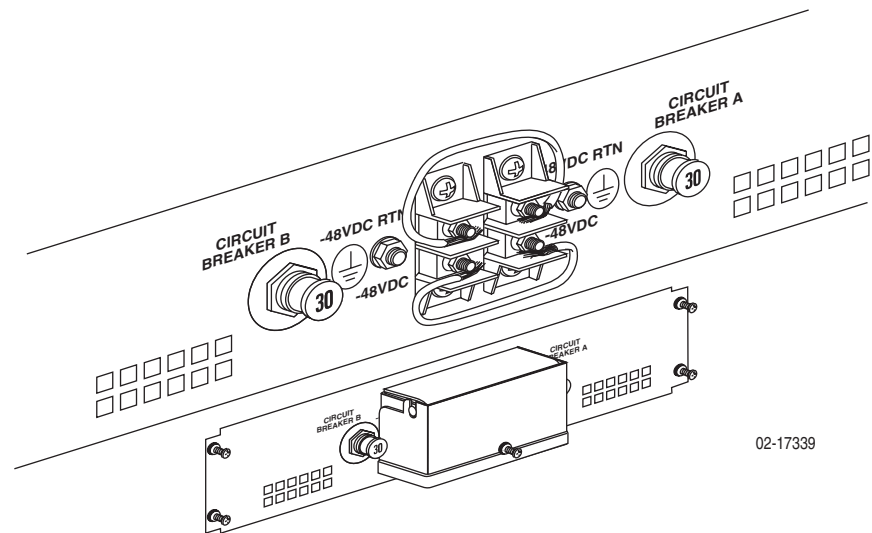

System Requirements for Release 3.2

Feature	CP	MP	ATM	12 port E1 ECAC	8 port E1	EC/ECAC
2000 IADs	CP1/CP2	MP3	2 ATM for redundancy	Supported	Supported	Supported (8 port only)
2000 calls	CP2	MP3	4 ATM for redundancy	360 calls/card Max Call limit: 2000 (6 cards)	240 calls/card Max Call limit: 1000 (5 cards)	672 calls/card (8 port only)
- Auto config - Fax Modem Detect - Dyn ECAN pots/ISDN	CP1/CP2	MP3	Supported	Supported	Supported	Supported (8 port only)

Upgrading from Previous Releases

Upgrading CPX-1000 shelves from release 3.1.2 to 3.2 requires:

- 3.2 software upgrade kit
- Upgrade cannot be completed while the CPX-1000 is up and running. This upgrade needs to be performed during a maintenance window as it is service-affecting.

Interoperability with Other Jetstream Products

JetCraft

JetCraft release 3.2 is compatible with CPX-1000 release 3.2 and not with previous releases. Previous versions of JetCraft will not interoperate with CPX-1000 release 3.2.

JetVision

JetVision release 3.2 is compatible with CPX-1000 release 3.2. Previous versions of JetVision will not interoperate with CPX-1000 release 3.2.

CPX-1000 System Compatibility

This table illustrates the CPX-1000 components of release 3.2.

CPX-1000 Component	Part Number
Common Equipment	
CPX-1000 Shelf – Redundant	1000-B1-510
CPX-1000 Shelf Redundant Enhanced	1000-B1-512
Software Release	
Release 3.2	1000-D1-004
Mounting Ears	
Bell Rack Mount Ears	1000-F1-001
NEBS 2000 Rack Mount Ears	1000-F1-002
I/O Modules	
PSTN Interface	
TDM 8 Port T1	1001-B1-001
TDM 12 Port T1 with ECAC	1001-B1-002
Packet Interface	
ATM-OC3S	1002-B1-001
ATM-OC3M	1002-B1-002
Resource Modules	
Echo Cancellation	1003-B1-001
Echo Cancellation and Compression	1003-B1-002
Common Equipment Spares	
CP for HA systems	1000-F1-200
CP2 for HA systems	1000-F1-201
HSC-HA/HS	1000-F1-202
PDU2 Power Unit for 200 AC chassis	1000-F1-802
MP-HA/HS	1000-F1-203
Other Spares	
CPX-1000 empty shelf	1000-F1-800
Power Supply Mod. – 48VDC	1000-F1-801
Direct Power Distribution Module	1000-F1-802
Fan Module	1000-F1-803
Alarm Module HA	1000-F1-804
Fan Filter	1000-F1-805
CPU Cables	1000-F1-502
Reset Button Cover Plate Assy.	1000-F1-910
Peripheral Components	
Cable Management System	1000-F1-500
Bezel Assembly	1000-F1-900
JetCraft 3.2	1000-D1-008
JetVision Windows 3.2	1010-D1-007
JetVision Solaris 3.2	1010-D1-008
Technical Documentation	
CPX-1000 Library 3.2	1000-M1-004
JetVision Library 3.2	1010-M1-004

Release 3.2 Considerations

System Configuration

Installation of any base module (front card) paired with a transition module (rear card) requires the following steps:

- When *removing* modules, remove the base module first, followed by the transition module.
- When *installing* modules, install the transition module first, followed by the base module.

The default setting for 1+1 ATM protection switching is set to OFF.

The MP module must always be installed in slot 6.

Use ports 1, 2, 3, 7, or 8 only as the clock sources on the Octal E1 cards.

If the CPX-1000 V5 Interface is connected to a Class V switch that has CRC4 set to OFF, and then the E1 card is removed, and the CPX-1000 is rebooted without the E1 card in place, then replace the E1 card after reboot and change the CRC4 setting to OFF for each applicable E1 port.

If a V5 Interface Group on the Class V switch has CRC set to OFF:

1. Create a V5 Interface Group.
2. Change CRC4 setting to OFF for each applicable E1 port.
3. Unlock the newly created V5 Interface Group.

IAD Configuration

To benefit from IAD notification of dynamic echo cancellation, the IAD must be compatible with Call Control Release 2.2.

Hot Swap/Growth

Perform hot swaps and hot growth one card at a time, ensuring that the swapped or new card initiates properly before hot-swapping or adding any other cards.

Hot Swap is only supported with a like card. If you remove a card, replace it with the same type of card.

If the tabs on a base module (front card) are accidentally unlatched, you must remove and re-insert the module to return it to the active state.

When performing an unplanned hot swap of any MP card, after releasing the latches, wait 120 seconds to remove the card.

When performing an unplanned hot swap of any other card, after releasing the latches, wait 10 seconds to remove the card.

When performing a hot swap of a CP card, always release the latch first. *Do not pull* the CP-to-CP cable before releasing the latch on the CP card.

Jetstream recommends performing hot swap and hot growth actions as scheduled maintenance activities.

Mixed PSTN Systems (12 port & 8 port)

If 12 port E1 and the Octal E1 cards are used in the same CPX chassis. The Octal card(s) must always provide the clock source. This is a hardware limitation of the Octal cards.

CP Card Behavior

The reset button on both CP cards should be pressed simultaneously for the entire CPX system to reset. Pressing a single reset button will not reset the CPX and may result in degradation of system performance. Customers may mount an optional cover plate (orderable with each CP) to prevent access to the reset and abort buttons.

Miscellaneous

When powering down the CPX or rebooting the system, backup the database first. Then use JetVision or JetCraft for the shutdown and reboot.

JetCraft and JetVision do not support Variant modifications. You must first delete and re-add the Variant ID.

If the CPX is restored with an old database (a DB backed up prior to new IAD provisioning), it will not provision new IADs until the DB is updated (synchronized) with the most recent IAD information (IADs which were added or deleted since last backup).

Removing an EC or ECAC card does not generate a **card removed or missing** alarm.

The CPX does not support alarm notification of transition cards.

Serial number information is not available on all components through the software.

Synchronize timing to ports 1, 2, 3, 7, or 8 on a valid Octal E1 card. Clocking is not supported for ports 4, 5, or 6 of any Octal E1 card.

If the database is configured, the CPX system requires installation of at least one line card to boot up properly.

The CPX-1000 does not support concurrent clock sources.

On rare occasions, IAD modifications may fail. This is due to the CPX's inaccurate status of the V5 Interface Group. Should this occur simply lock and unlock the Interface Group from JetVision or JetCraft.

Known Issues in Release 3.2

Description	Workaround
Timing problems with mixed 8 port and 12 port PSTN systems.	Enter all 8 port E1 cards in the clocking table as higher priority than 12 port E1 cards.
When using an external SNMP management tool to query IADs subtended from a scaled CPX-1000 system, the SNMP manager may time out due to the time it takes for the query to execute.	Increase the timer value on the SNMP management tool more than 20 seconds.
While an STM-1 card is unlocked, and a port is locked no alarm will be generated.	For this single port STM-1 card, lock at the card level only.
When a new interface group is first provisioned, and the IG is locked at the LE, no alarm will be raised.	Unlock IG at LE prior to unlocking IG at CPX.
A screech can sometimes be heard, if hot swapping the Octal E1 card during phone calls.	Hot swap Octal E1 during a scheduled maintenance window.

Issues Resolved in Release 3.2

Description	Status
If a V5 Interface Group is in an unlocked/disabled state, the interface will revert to a Locked state after CP Switchover, even though JetCraft/JetVision show the interface unlocked/disabled.	Resolved.
False alarms may be raised for a few seconds if the link (short cable) is removed between the two CP modules.	Resolved.
DS1 clock source is not correct after a planned hot swap of an E1 card.	Resolved.

Warranty, Sales, Service, and Training Information

Contact your local sales representative, service representative, or distributor directly for any help needed. For additional information concerning warranty, sales, service, repair, installation, documentation, training, distributor locations, or Paradyne worldwide office locations, use one of the following methods:

- **Internet:** Visit the Paradyne World Wide Web site at **www.paradyne.com**. (Be sure to register your warranty at **www.paradyne.com/warranty**.)
- **Telephone:** Call our automated system to receive current information by fax or to speak with a company representative.
 - Within the U.S.A., call 1-800-870-2221
 - Outside the U.S.A., call 1-727-530-2340