



AREA CODE CHANGE

Please note that the area code for Paradyne Corporation in Largo, Florida has changed from 813 to 727.

For any Paradyne telephone number that appears in this manual with an 813 area code, dial 727 instead.

HotWire 5216 Remote Termination Unit (RTU) Customer Premises Installation Instructions

Document Number 5216-A2-GN10-00

October 1997

Before You Begin

An optional POTS (Plain Old Telephone Service) splitter is available for the 5446 RTU. When a POTS splitter is installed, the telephone and 5216 RADSL (Rate Adaptive Digital Subscriber Line) RTU can function at the same time over the same pair of copper wires. In order to confirm the RTU installation, the POTS splitter should be installed first. To install a POTS splitter, refer to the appropriate POTS splitter document:

Document Number	Document Title
5030-A2-GN10	<i>HotWire 5030 POTS Splitter Customer Premises Installation Instructions</i>
5034-A2-GN10	<i>HotWire 5034 Indoor POTS Splitter Customer Premises Installation Instructions</i>

Wiring and Cables Needed

The following wiring and standard connectors are used with this product:

- New or existing unshielded twisted-pair wiring (CAT3 or better). The CAT3 wiring must meet EIA/TIA-568 specifications with 24 AWG (.5 mm) or 26 AWG (.4 mm).
- Standard RJ11 wall jack.
- Standard Ethernet crossover cable with an 8-pin, non-keyed modular plug for a PC or workstation. Refer to *Installing the RTU*, page 6, for Ethernet cable details.

Package Checklist

Verify that your package contains the following:

- Model 5216 Remote Termination Unit (RTU)
- DSL interface cable with RJ11 modular plugs
- Power cord with power transformer
- Ferrite choke
- Warranty card

Refer to *Cables & Connectors*, page 11, for standard pin numbers.

What Does the HotWire RTU Do?

The 5216 RTU is a component in the DSL Access System. This system provides high-speed Internet or corporate LAN access over traditional twisted-pair copper telephone wiring.

DSL Access with a POTS Splitter

Copper pairs run from the central office (CO) to the customer premises (CP) to create the local loop. The local loop terminates on the customer premises at the demarcation point in a punchdown block or network interface device (NID).

When a POTS splitter is used at both ends of the local loop, wiring is connected:

- From the demarcation point to the CP POTS splitter, and
- From the demarcation point to the DSL jack.

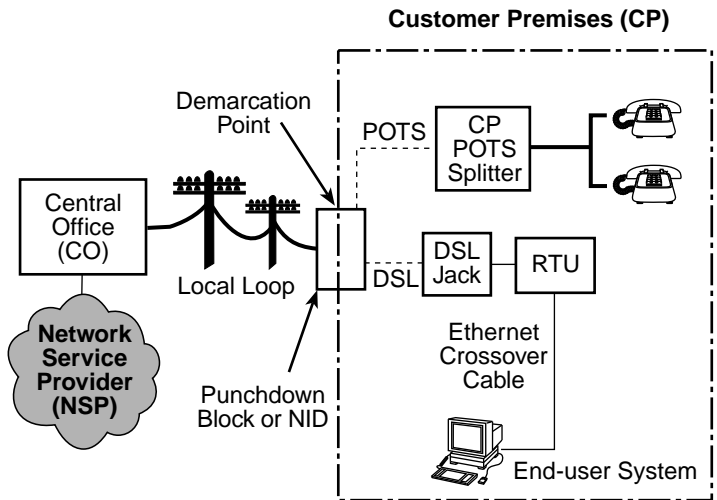

97-15608

DSL - Digital Subscriber Line POTS - Plain Old Telephone Service
NID - Network Interface Device RTU - Remote Termination Unit

----- New Wiring Connections — Existing Wiring (POTS)

NOTES:

- PC is used to represent any end-user system with an Ethernet connection and DSL-based service.
- Network Service Provider (NSP) is used to represent any Internet Service Provider (ISP) or internal LAN administrator.

DSL Access without a POTS Splitter

When the 5126 RTU is installed without a POTS splitter, a second telephone wiring pair is needed for DSL access.

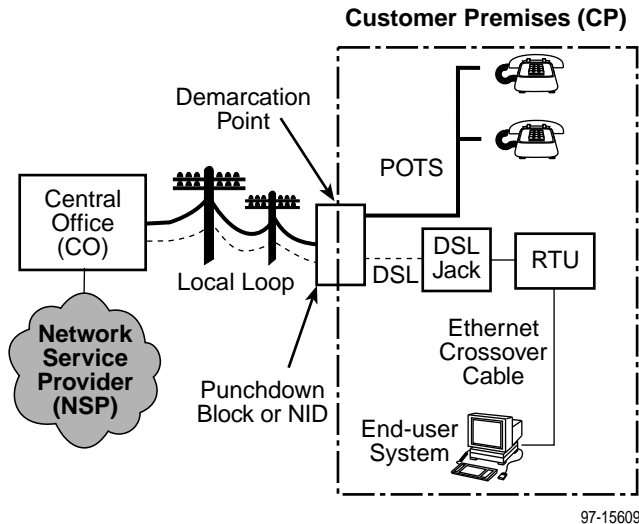

DSL - Digital Subscriber Line

NID - Network Interface Device

POTS - Plain Old Telephone Service

RTU - Remote Termination Unit

----- New Wiring Connections

———— Existing Wiring (POTS)

Installing the DSL Access Wiring

The local loop ends at the punchdown block or NID. Wiring must be connected from the customer premises side of the punchdown block or the NID to the DSL jack. Typically, the punchdown block is installed in commercial locations and the NID is installed in residential locations.

► Procedure

1. Access the punchdown block or NID. Disconnect the DSL access pair from the local loop.

⚠ WARNING:

Do not continue unless the DSL access line from the local loop has been disconnected at the NID or punchdown block. Refer to *Important Safety Instructions*, page 13.

A punchdown block is used without a POTS splitter in the following example.

Punchdown Block

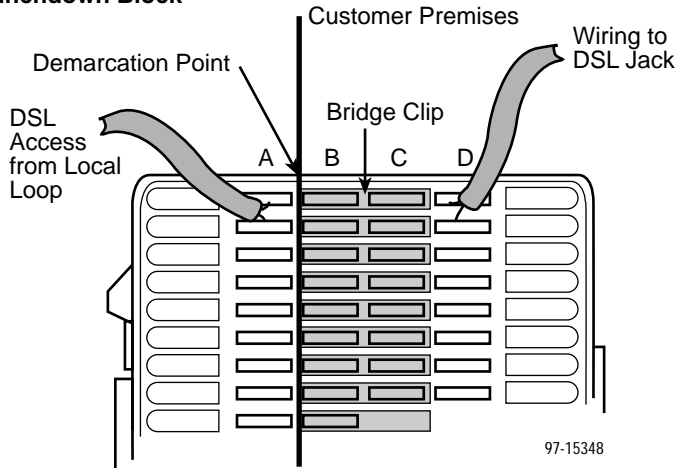

Green (T1) and red (R1) are the standard wiring colors used in the next two illustrations.

In the next example, a NID is used without a POTS splitter. It includes an existing POTS line and a second pair installed for DSL access. The pair for the POTS line does not need to be disconnected unless a POTS splitter is going to be installed.

Telephone Network Interface Device (NID)

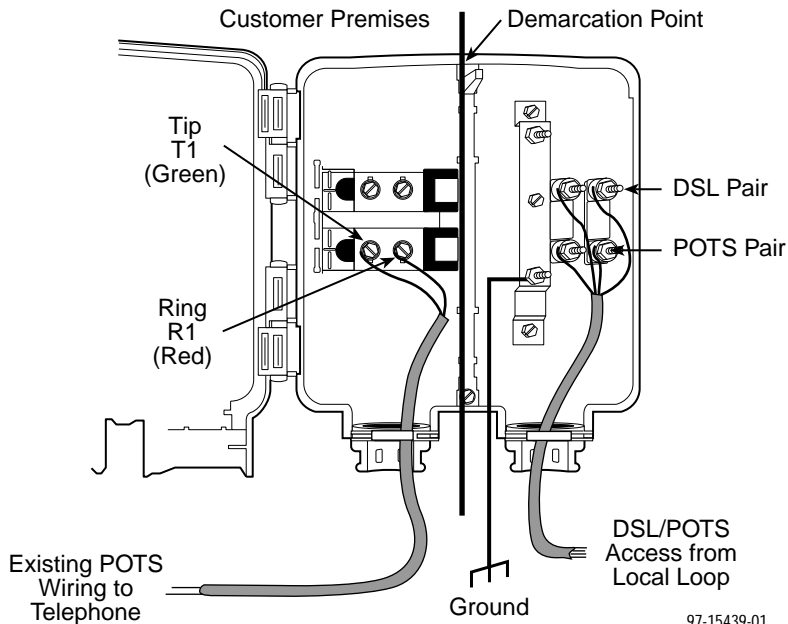

2. Locate the DSL pair of T1/R1 connectors on the customer premises side of the NID or punchdown block. Attach the wiring that will be connected to the DSL jack. Tighten both terminal screws with a flat-blade screwdriver.

Telephone Network Interface Device (NID)

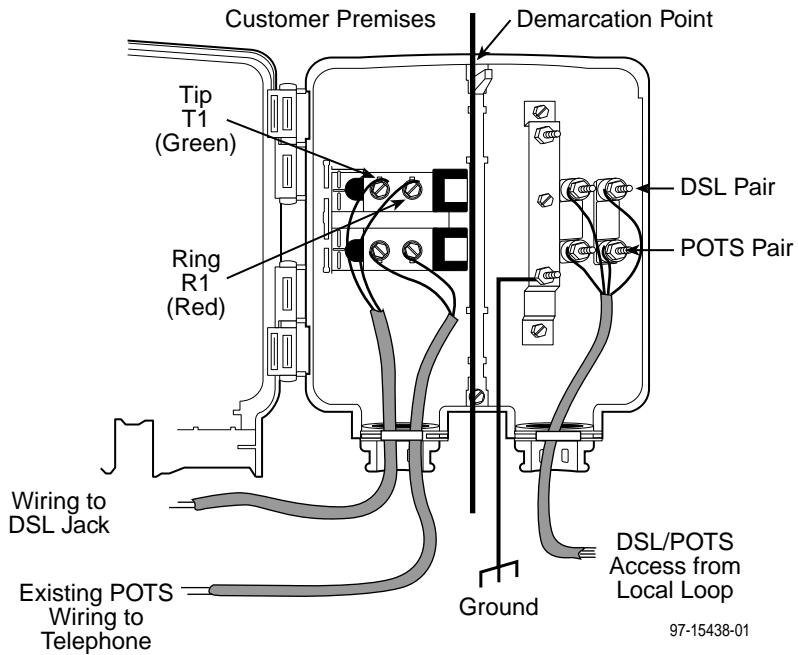

DSL Jack Installation

The RTU connects to the local loop via wiring from the demarcation point to an RJ11 wall jack. The DSL twisted-pair wiring from the local loop terminates at a new or existing wall jack. It may be necessary to install a standard single RJ11 jack or replace a single jack with a double RJ11 jack.

The RJ11 6-pin jack uses the center two pins. For pin assignments, refer to *Cables & Connectors*, page 11.

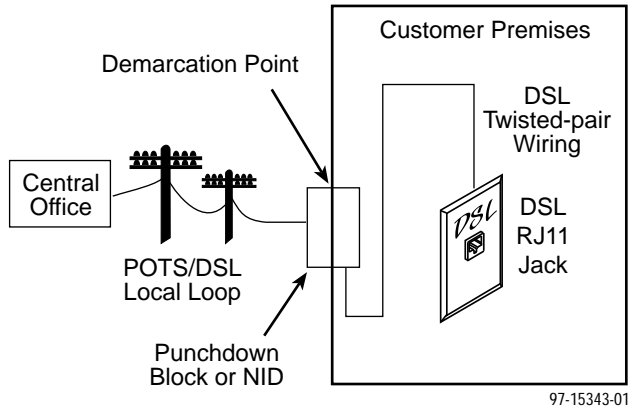

► Procedure

1. Wiring can be run from the punchdown block or NID to a new or existing wall jack. Match the pair colors on both ends.
2. Label the DSL jack.

RJ11 Wall Jack

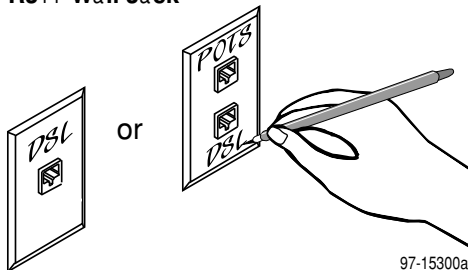

3. At the demarcation point, reconnect the DSL access wire pair to the local loop. Refer to *Installing the DSL Access Wiring*, page 3. Tighten both terminal screws with a flat-blade screwdriver.

Installing the RTU

Place the 5216 RTU on a flat surface with clearance for the rear connectors.

► Procedure

1. Use the RJ11 6-pin cable for the DSL connection. Insert one end of the cable into the jack labeled DSL. Insert the other end into the wall jack labeled DSL.

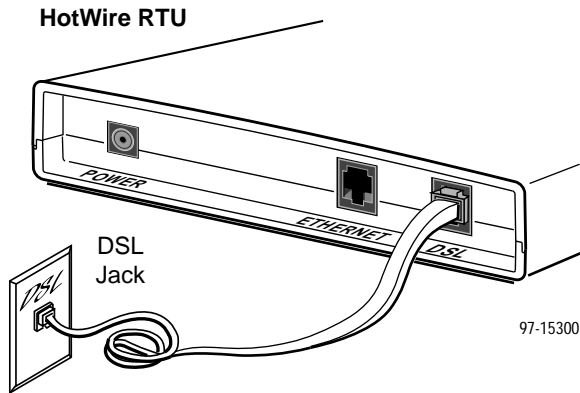

2. Use an 8-pin Ethernet crossover cable for the Ethernet connection. Insert one end of the cable into the jack labeled ETHERNET. Connect the other end to a PC with an Ethernet Network Interface Card (NIC).

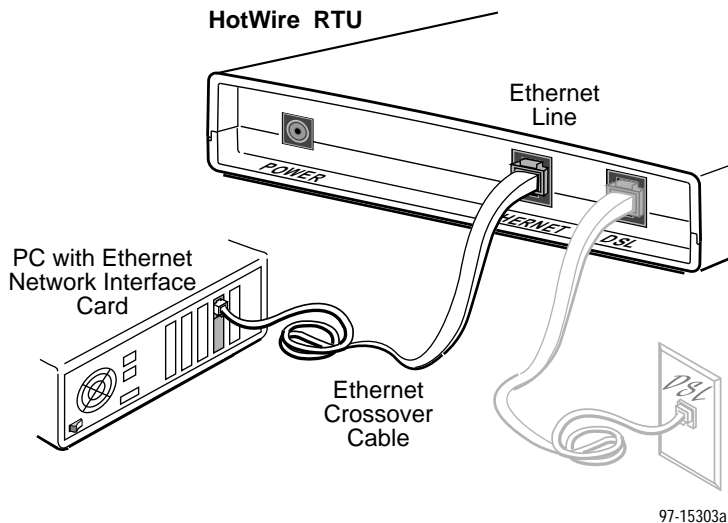

For RTU cable pin assignments, refer to *Cables & Connectors*, page 11.

- Place the supplied ferrite choke on the Ethernet cable as closely as possible to the RTU. Pass the Ethernet cable through the ferrite choke twice, creating a loop as shown.

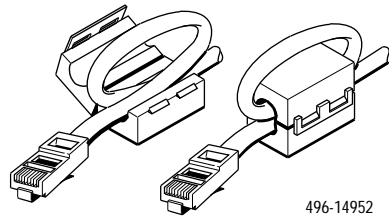

- Close the two halves around the cable and snap the ferrite choke shut. Press down on the plastic latch to secure the ferrite choke in place around the cable.

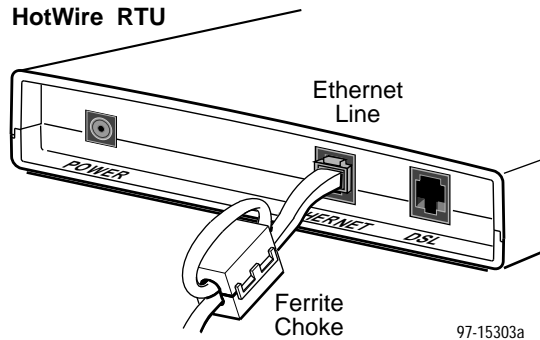

- Insert the power cord's round end into the jack labeled POWER. Plug the transformer into an AC outlet.

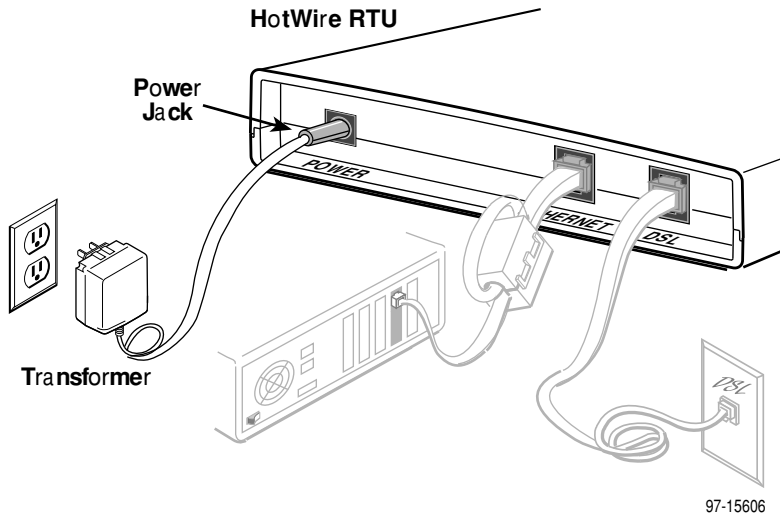

The RTU hardware installation is now complete. When the power cord is installed, the RTU goes through a power-on self-test.

Power-On

When power is applied, the RTU performs self-diagnostics and the PWR LED is on. The self-diagnostics includes a power-on self-test. During the power-on self-test, all of the LEDs turn on for one second.

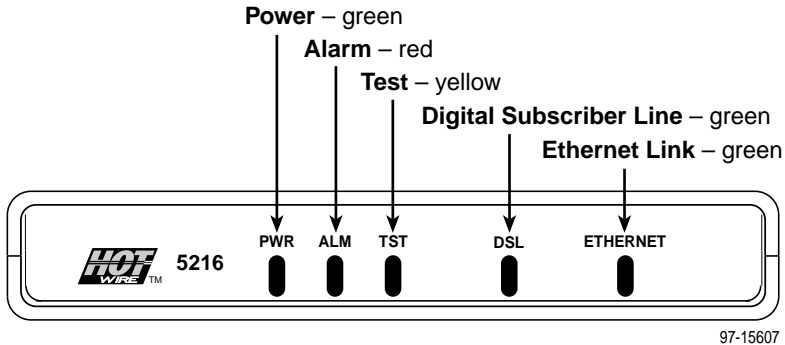

Refer to *Troubleshooting*, page 10, for LED indications requiring action.

Status LEDs

All of the LEDs turn on and off during the power-on self-test. After a successful self-test, the LEDs should appear as indicated in **BOLD** in the Condition column below.

LED	Condition	Status
PWR	ON	RTU has power.
ALM	OFF	No active alarms.
	ON	An alarm condition exists.
TST	OFF	No active tests.
	ON	The TST LED is on during the power-on self-test and during a test initiated by the NSP.
DSL	Blinking	RTU is establishing the DSL link. The LED blinks on and off about five times per second.
	ON	The DSL link is now active and ready to transmit and receive data.
	OFF	The DSL link has not been established.
ETHERNET	ON	The Ethernet 10BaseT connection to the end-user system is active.
	OFF	No Ethernet 10BaseT device is detected.

Firmware Download

The firmware download feature is available via the Ethernet port for future upgrades. During a firmware download, the LED displays are:

- ON: ALM, ETHERNET, PWR, and TST
- OFF: DSL

Troubleshooting

LED Symptom	Action
All LEDs are on.	The RTU is not functional. Contact the NSP.
ALM LED remains on.	The power-on self-test may have failed. Unplug the unit and reapply power. If the alarm light is still on, contact the NSP.
ALM and TST LEDs remain on.	Refer to <i>Firmware Download</i> . If the LEDs remain on after five minutes, contact the NSP.
DSL LED is off.	Verify that the DSL cable is securely installed on both ends.
	If the RTU is not in firmware download mode, unplug the RTU and reapply power. If problem continues, contact the NSP.
DSL LED continues to blink after the power-on self-test.	The RTU is attempting to establish the DSL link. If the DSL LED continues to blink for more than five minutes, contact the NSP.
DSL LED is on and there is no data transmission.	The DSL link has been established but there is no data transmission. First, verify the Ethernet connection. If the problem persists, contact the NSP.
DSL and Ethernet LEDs are on and there is no data transmission.	The DSL link and the Ethernet link have been established. If the problem continues, contact the NSP.
Ethernet LED is off.	Verify that: <ul style="list-style-type: none">■ The Ethernet 10BaseT cable is securely installed at both ends, and■ At least one PC is connected and powered on.
	Verify that the correct crossover cable is installed. Refer to <i>Cables & Connectors</i> , page 11.

LED Symptom	Action
PWR LED is off.	Check that the power cord is securely installed on both ends.
	If no LEDs are on, the power supply may be defective. Try a different outlet to test the power supply. If problem persists, contact the NSP.
	If other LEDs are on, the PWR light may be burned out. Unplug the unit and reapply power; watch all LEDs during the power-on self-test to verify that other LEDs are functioning.
TST LED is on.	A test initiated by the NSP may be active. Wait five minutes. If the TST LED does not go off, contact the NSP.

Cables & Connectors

Obtain standard twisted-pair CAT3 or better cables.

This section is reference information.

- The DSL interface connector uses a 6-pin, non-keyed modular plug.

RJ11 6-Pin Connector

Pin #	Function
1 & 2	Not used
3	DSL Ring
4	DSL Tip
5 & 6	Not used

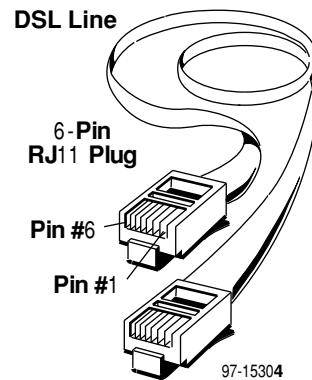

- The Ethernet interface crossover cable connector uses an 8-pin, non-keyed modular plug.

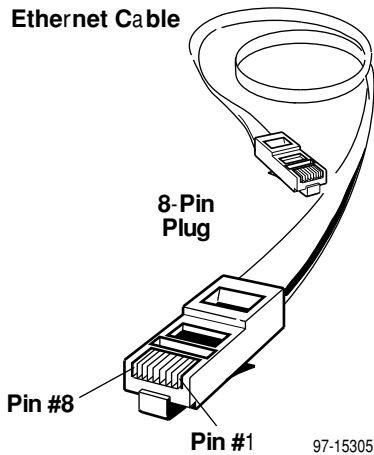

8-Pin Ethernet Crossover Cable

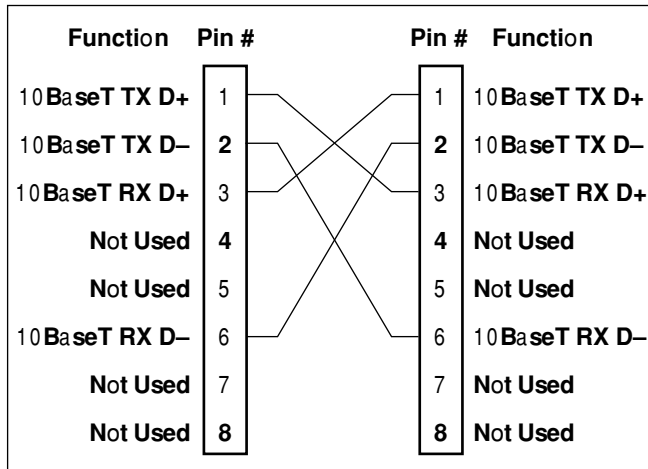

97-15316

Model 5216 RTU Technical Specifications

Item	Specification*
Height x Width x Depth	1.35" x 6.00" x 8.75" (3.43 cm x 15.35 cm x 22.23 cm)
Weight	1 lb. 1 oz. (0.48 kg)
Power Class 2 Transformer normal service input voltage range	Input: 100 Vac, 50 Hz; 120 Vac, 60 Hz; or 230 Vac, 50/60 Hz Output: 15 Vdc nominal ($\pm 10\%$), minimum 0.6A
Approvals FCC Part 15 CISPR 22 Safety Certifications	Class B Subpart B digital device Class B Refer to equipment's label for approvals on product.
Physical Environment Operating temperature Storage temperature Relative humidity Shock and vibration	32° F to 104° F (0° C to 40° C) -4° F to 158° F (-20° C to 70° C) 5% to 95% (noncondensing) Withstands normal shipping and handling
Heat Dissipation	40.9 Btu/hr. (max.) at nominal input voltage
Interface Connectors DSL Interface Ethernet Type II Frame	RJ11 6-pin 10BaseT 8-pin
* Technical Specifications subject to change without notification.	

Important Safety Instructions

1. Read and follow all warning notices and instructions marked on the product or included in the manual.
2. Slots and openings in the cabinet are provided for ventilation. To ensure reliable operation of the product and to protect it from overheating, these slots and openings must not be blocked or covered.
3. Do not allow anything to rest on the power cord and do not locate the product where persons will walk on the power cord.
4. Do not attempt to service this product yourself, as opening or removing covers may expose you to dangerous high voltage points or other risks. Refer all servicing to qualified service personnel.

-
5. General purpose cables are used with this product for connection to the network. Special cables, which may be required by the regulatory inspection authority for the installation site, are the responsibility of the customer. Use a UL Listed, CSA certified, minimum No. 24 AWG line cord for connection to the Digital Subscriber Line (DSL) network.
 6. When installed in the final configuration, the product must comply with the applicable Safety Standards and regulatory requirements of the country in which it is installed. If necessary, consult with the appropriate regulatory agencies and inspection authorities to ensure compliance.
 7. A rare phenomenon can create a voltage potential between the earth grounds of two or more buildings. If products installed in separate buildings are **interconnected**, the voltage potential may cause a hazardous condition. Consult a qualified electrical consultant to determine whether or not this phenomenon exists and, if necessary, implement corrective action prior to interconnecting the products.
 8. Input power to this product must be provided by one of the following: (1) a UL Listed/CSA certified power source with a Class 2 or Limited Power Source (LPS) output for use in North America, or (2) a certified transformer, with a Safety Extra Low Voltage (SELV) output having a maximum 240 VA available, for use in the country of installation.
 9. In addition, since the equipment is to be used with telecommunications circuits, take the following precautions:
 - Never install telephone wiring during a lightning storm.
 - Never install telephone jacks in wet locations unless the jack is specifically designed for wet locations.
 - Never touch uninsulated telephone wires or terminals unless the telephone line has been disconnected at the network interface.
 - Use caution when installing or modifying telephone lines.
 - Avoid using a telephone (other than a cordless type) during an electrical storm. There may be a remote risk of electric shock from lightning.
 - Do not use the telephone to report a gas leak in the vicinity of the leak.

CE Marking

When the product is marked with the CE mark on the equipment label, this demonstrates full compliance with the following European Directives:

- Directive 73/23/EEC – Council Directive of 19 February 1973 on the harmonization of the laws of the member states relating to electrical equipment designed for use within states relating to electrical equipment designed for use within certain voltage limits, as amended by Directive 93/68/EEC.
- Directive 89/336/EEC – Council Directive of 3 May 1989 on the approximation of the laws of the member states relating to Electro-Magnetic Compatibility (EMC), as amended by Directive 93/68/EEC.

Japan

Class 2 ITE

この装置は、情報処理装置等電波障害自主規制協議会（VCCI）の基準に基づく第二種情報技術装置です。この装置は、家庭環境で使用することを目的としていますが、この装置がラジオやテレビジョン受信機に近接して使用されると、受信障害を引き起こすことがあります。
取扱説明書に従って正しい取り扱いをして下さい。

This is a Class 2 product based on the standard of the Voluntary Control Council for Interference from Information Technology Equipment (VCCI). If this is used near a radio or television receiver in a domestic environment, it may cause radio interference. Install and use the equipment according to the instruction manual.

Declaration of Conformity

This Declaration of Conformity is made by Paradyne Corporation pursuant to Parts 2 and 15 of the Federal Communications Commission's Rules. This compliance information statement pertains to the following products:

Trade Name: HotWire
Model Number: 5216-A1-200

This device complies with Part 15 of the FCC Rules. Operation is subject to the following two conditions: (1) this device may not cause harmful interference, and (2) this device must accept any interference received, including interference that may cause undesired operation.

The name, address, and telephone number of the responsible party is given below:

Paradyne Corporation
8545 126th Avenue North
Largo, FL 33773-1502
Phone: (813) 530-2000

The authority to operate this equipment is conditioned by the requirement that no modifications will be made to the equipment unless the changes or modifications are expressly approved by Paradyne Corporation.

In order to maintain compliance with Part 15, FCC rules, the clamp-on ferrite choke must be installed on the Ethernet cable in accordance with the installation instructions.

EMI Warnings

WARNING:

To Users of Digital Apparatus in Canada:

This Class B digital apparatus meets all requirements of the Canadian interference-causing equipment regulations.

Cet appareil numérique de la classe B respecte toutes les exigences du règlement sur le matériel brouilleur du Canada.

Notice to Users of the Canadian Telephone Network

The Industry Canada label identifies certified equipment. This certification means that the equipment meets telecommunications network protective, operational and safety requirements as prescribed in the appropriate Terminal Equipment Technical Requirements document(s). The Department does not guarantee the equipment will operate to the user's satisfaction.

Before installing this equipment, users should ensure that it is permissible to be connected to the facilities of the local telecommunications company. The equipment must also be installed using an acceptable method of connection. The customer should be aware that compliance with the above conditions may not prevent degradation of service in some situations.

Repairs to certified equipment should be coordinated by a representative designated by the supplier. Any repairs or alterations made by the user to this equipment, or equipment malfunctions, may give the telecommunications company cause to request to disconnect the equipment.

Users should ensure for their own protection that the electrical ground connections of the power utility, telephone lines and internal metallic water pipe system, if present, are connected together. This precaution may be particularly important in rural areas.

CAUTION:

Users should not attempt to make such connections themselves, but should contact the appropriate electric inspection authority, or electrician, as appropriate.

The Ringer Equivalence Number (REN) assigned to each terminal device provides an indication of the maximum number of terminals allowed to be connected to a telephone interface. The termination on an interface may consist of any combination of devices subject only to the requirement that the sum of the Ringer Equivalence Numbers of all the devices does not exceed 5.

If your equipment is in need of repair, refer to the next section.

Warranty, Sales, and Service Information

Contact your sales or service representative directly for any help needed. For additional information concerning warranty, sales, service, repair, installation, documentation, or training, use one of the following methods:

- **Via the Internet:** Visit the Paradyne World Wide Web site at <http://www.paradyne.com>
- **Via Telephone:** Call our automated call system to receive current information via fax or to speak with a company representative.
 - Within the U.S.A., call 1-800-870-2221
 - International, call 813-530-2340



5216-A2-GN10-00