

Hotwire® 5216 RTU Customer Premises Installation Instructions

Document Number 5216-A2-GN10-30

August 2000

Contents

What Does the Hotwire 5216 RTU Do?	1
Installing the DSL Access Wiring	5
Installing the Hotwire 5216 RTU	8
Status LEDs	10
Troubleshooting	11
Cables & Connectors	12
Important Safety Instructions	16

What Does the Hotwire 5216 RTU Do?

The Hotwire® 5216 RTU (Remote Termination Unit) is a component in the Hotwire RADSL Access System and interoperates with the Hotwire 8540 DSL Card in the DSLAM (Digital Subscriber Line Access Multiplexer) system. This system provides high-speed Internet or corporate LAN access over traditional twisted-pair copper telephone wiring.

Copper pairs run from the central office (CO) to the customer premises (CP) to create the local loop. The local loop terminates on the customer premises at the demarcation point in a punchdown block or network interface device (NID).

Optional POTS Splitter

An optional POTS (plain old telephone service) splitter can be installed to block out the DSL signal and allow the POTS frequencies to pass through. At the customer premises, the 5216 RTU and a telephone can function simultaneously over the same pair of copper wires when either:

- A Hotwire 5030 or 5038 POTS Splitter is installed near the demarcation point for all telephones on the same POTS line as DSL, *or*
- A Hotwire 5038 Distributed POTS Filter is installed on each telephone on the same POTS line as DSL.

NOTES:

In this document:

- End-user system is used to represent any host with an Ethernet connection.
- Service provider is used to represent any Internet Service Provider (ISP) or remote LAN access provider.

DSL Access without a POTS Splitter

When the Hotwire 5216 RTU is installed without a POTS splitter, the DSL line is used for data only and does not provide telephone services.

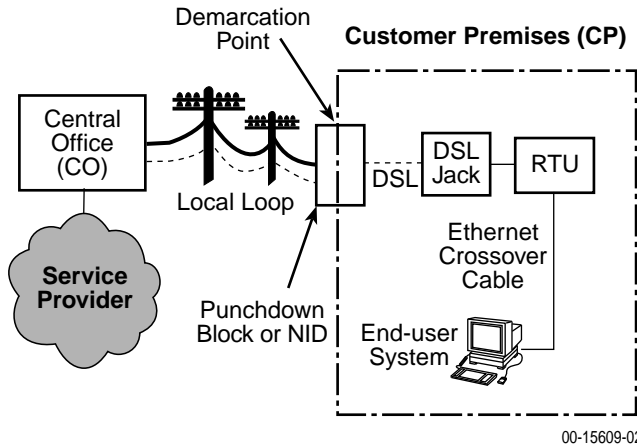

DSL – Digital Subscriber Line
NID – Network Interface Device

RTU – Remote Termination Unit
----- New Wiring Connections

DSL Access with a Hotwire 5030 or 5038 POTS Splitter

When a Hotwire POTS splitter is used at both ends of the local loop, wiring is connected:

- From the demarcation point to the CP POTS splitter, and
- From the demarcation point to the DSL jack.

The Hotwire 5030 POTS splitter is designed for outdoor or indoor installation. The Hotwire 5038 Distributed POTS Splitter is designed for indoor use only.

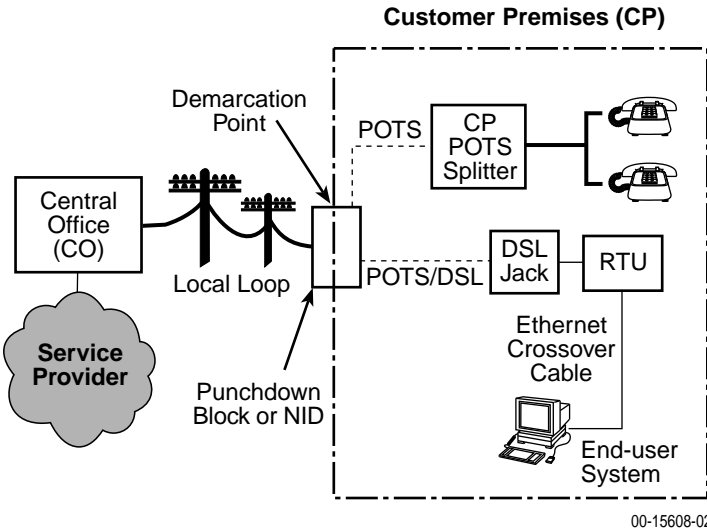

DSL – Digital Subscriber Line POTS – Plain Old Telephone Service
 NID – Network Interface Device RTU – Remote Termination Unit

----- New Wiring Connections — Existing Wiring (POTS)

DSL Access with a Hotwire 5038 Distributed POTS Splitter

When a Hotwire 5038 Distributed POTS Splitter is used, one 5038 Distributed POTS Splitter is installed as a phone filter for each telephone on the same POTS line as DSL.

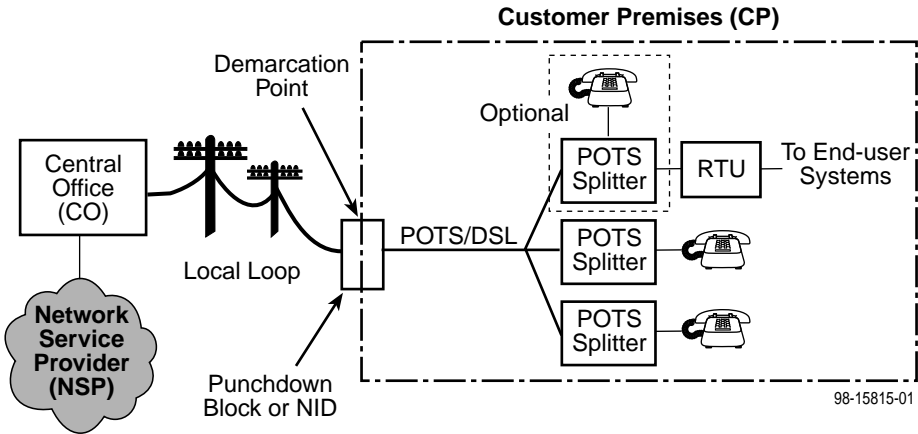

DSL – Digital Subscriber Line POTS – Plain Old Telephone Service
 NID – Network Interface Device RTU – Remote Termination Unit

Product-Related Documents

To install a POTS splitter, refer to the appropriate POTS splitter document:

Document Number	Document Title
5030-A2-GN10	<i>Hotwire 5030 POTS Splitter Customer Premises Installation Instructions</i>
5038-A2-GN10	<i>Hotwire 5038 Distributed POTS Splitter Customer Premises Installation Instructions</i>

Contact your sales or service representative to order additional product documentation.

Paradyne documents are available on the World Wide Web at **www.paradyne.com**.
Select *Library* → *Technical Manuals* → *Hotwire DSL & MVL Systems*.

Package Checklist

Verify that your package contains the following:

- Model 5216 Remote Termination Unit (RTU)
- DSL interface cable with RJ11 modular plugs
- Power cord with power transformer

Wiring and Cables You Need

The following wiring and standard connectors are used with this product:

- Standard RJ11 wall jack for the DSL cabling.
- DSL cabling: New or existing unshielded twisted-pair wiring (CAT3 or better). The CAT3 wiring must meet EIA/TIA-568 specifications with 24 AWG (.5 mm) or 26 AWG (.4 mm).
- Ethernet cabling: Standard Ethernet crossover cable with an 8-pin, non-keyed modular plug for a PC or workstation. Refer to *Installing the Hotwire 5216 RTU* on page 8 for Ethernet cable details.

Refer to *Cables & Connectors* on page 12 for standard pin numbers.

Installing the DSL Access Wiring

The local loop terminates at the punchdown block or NID. Wiring must be connected from the customer premises side of the punchdown block or the NID to an RJ11 jack. Typically, the punchdown block is installed in commercial locations and the NID is installed in residential locations.

► Procedure

1. Access the punchdown block or NID.
2. Disconnect the DSL access pair from the local loop.

⚠ WARNING:

Do not continue unless the DSL access line from the local loop has been disconnected at the NID or punchdown block. Refer to *Important Safety Instructions* on page 16.

A punchdown block is used without a POTS splitter in the following example.

Punchdown Block

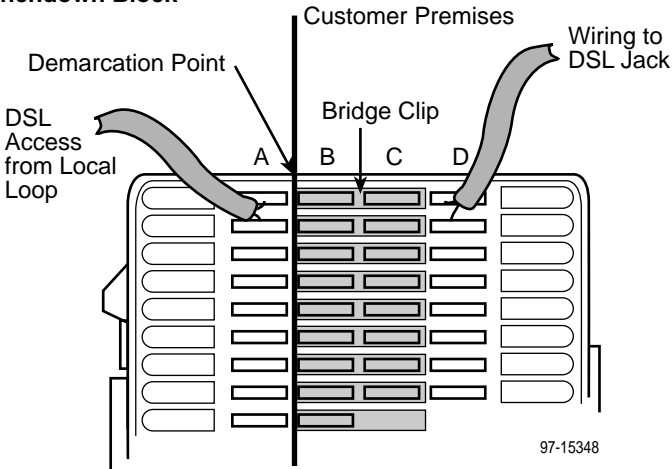

3. Locate the DSL pair of T1/R1 connectors on the customer premises side of the NID or punchdown block. Attach the wiring that will be connected to the DSL jack. In the following example, a NID is used without a POTS splitter. It includes an existing POTS line and a second pair installed for DSL access.

Telephone Network Interface Device (NID)

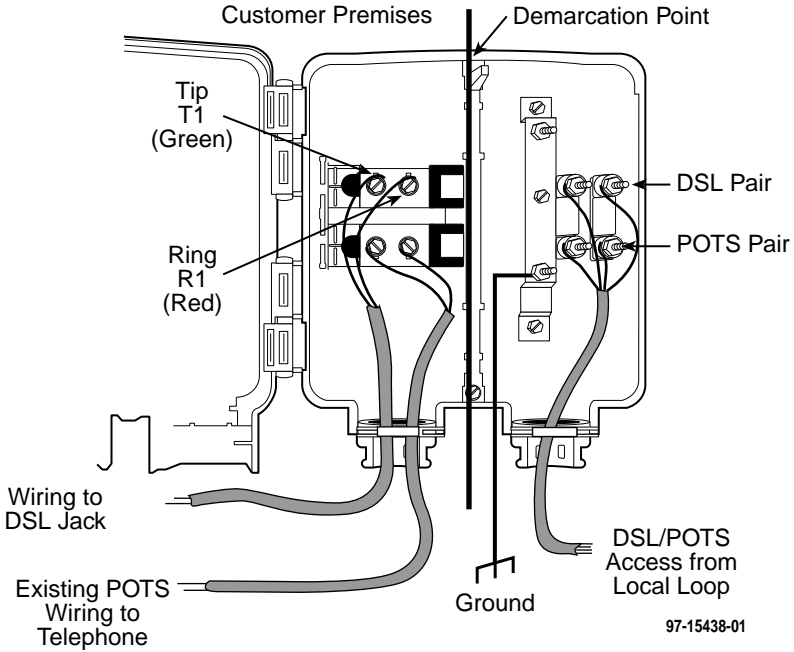

Connecting to the DSL Access Wiring

The Hotwire 5216 RTU connects to the local loop via wiring from the demarcation point to an RJ11 wall jack. The DSL twisted-pair wiring from the local loop terminates at a new or existing wall jack. It may be necessary to install a standard single RJ11 jack or replace a single jack with a double RJ11 jack.

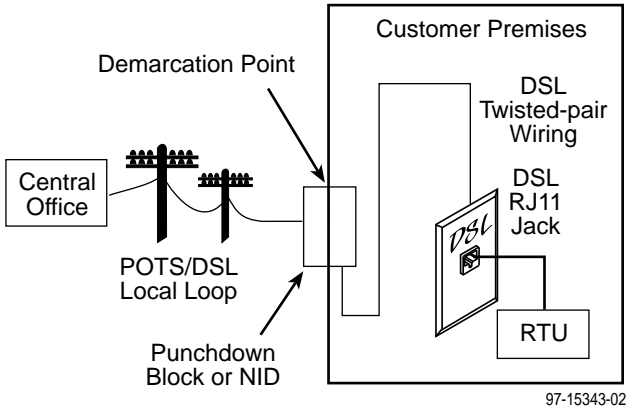

► Procedure

1. Wiring can be run from the punchdown block or NID to a new or existing wall jack. Match the pair colors on both ends.
2. Label the DSL jack.
3. Reconnect the DSL access pair at the punchdown block or NID. Refer to *Installing the DSL Access Wiring* on page 5. Tighten both terminal screws with a flat-blade screwdriver.

RJ11 Wall Jack

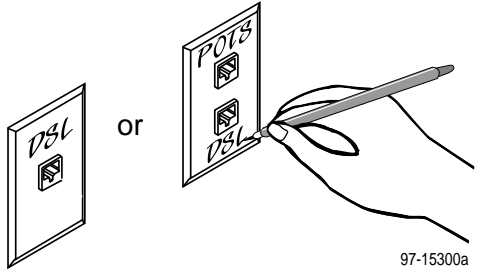

The RJ11 6-pin jack uses the center two pins. For pin assignments, refer to *Cables & Connectors* on page 12.

Installing the Hotwire 5216 RTU

Place the Hotwire 5216 RTU on a flat surface with clearance for the rear connectors.

► Procedure

1. Use the supplied RJ11 6-pin interface cable for the DSL connection. Insert one end of the cable into the jack labeled DSL. Insert the other end into the wall jack labeled DSL.

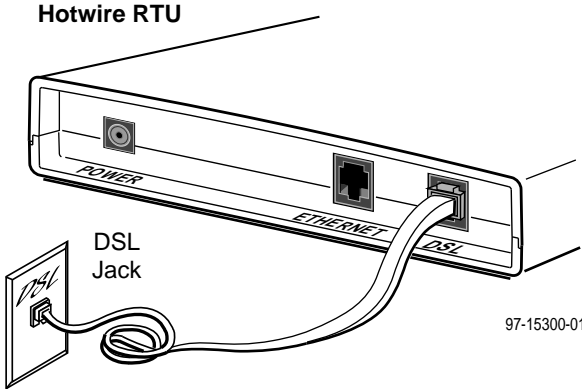

If the Hotwire 5216 RTU is installed on the same line as POTS, a Hotwire 5038 Distributed POTS Splitter can be used as a phone filter. One 5038 Distributed POTS splitter is installed as a phone filter for each telephone on the POTS/DSL line, as shown below. To install the Hotwire 5038 Distributed POTS splitter, refer to the *Hotwire 5038 Distributed POTS Splitter Customer Premises Installation Instructions*.

Customer Premises (CP)

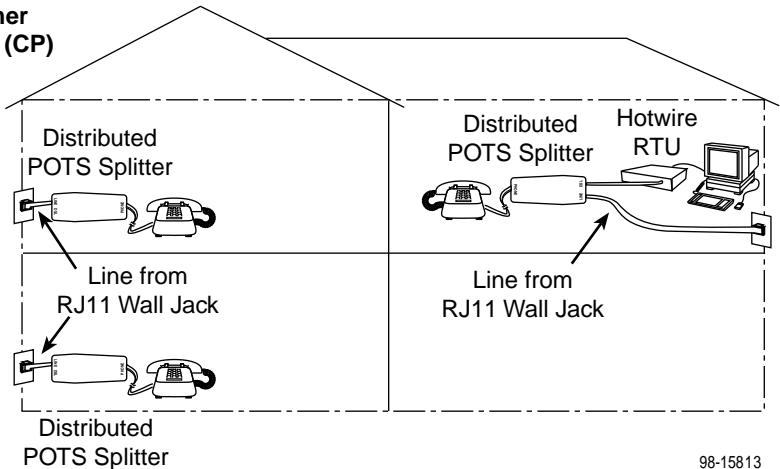

-
2. Use an 8-pin Ethernet crossover cable for the Ethernet connection. Insert one end of the cable into the jack labeled ETHERNET. Connect the other end to the Ethernet Network Interface Card (NIC) installed in the PC.

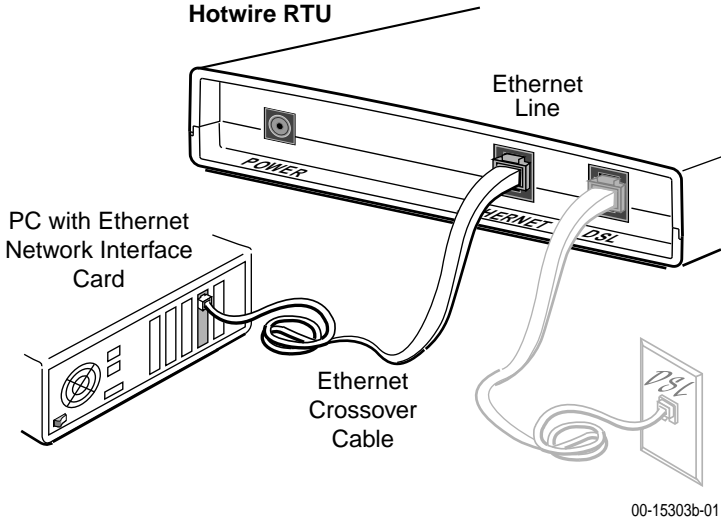

For RTU cable pin assignments, refer to *Cables & Connectors* on page 12.

3. Insert the supplied power cord's round end into the jack labeled POWER. Plug the transformer into an AC outlet.

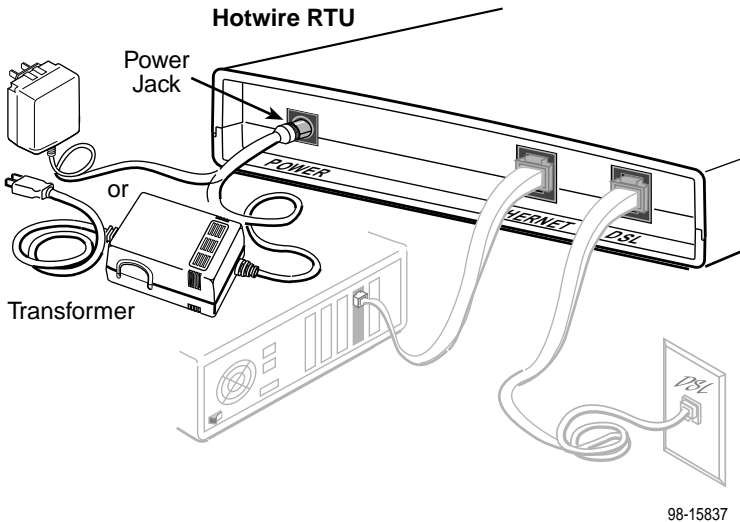

The RTU hardware installation is now complete. When the power cord is installed, the RTU goes through a power-on self-test.

Power-On

When power is applied, the RTU performs self-diagnostics and the PWR LED is on. The self-diagnostics includes a power-on self-test. During the power-on self-test, all of the LEDs turn on for one second.

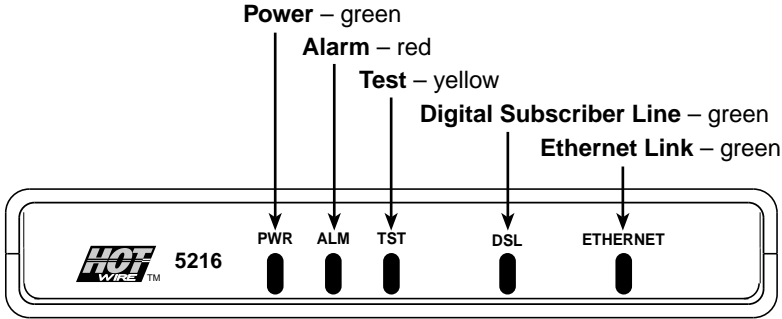

97-15607

Refer to *Troubleshooting* on page 11 for LED indications requiring action.

Status LEDs

All of the LEDs turn on and off during the power-on self-test. After a successful self-test, the LEDs should appear as indicated in **BOLD** in the Condition column below.

LED	Condition	Status
PWR	ON	The RTU has power.
ALM	OFF	No active alarms.
	ON	An alarm condition exists.
TST	OFF	No active tests.
	ON	The TST LED is on during the power-on self-test and during a test initiated by the service provider.
DSL	Blinking	RTU is establishing the active DSL link. The LED blinks on and off about five times per second.
	ON	The DSL link is now active and ready to transmit and receive data.
	OFF	The DSL link has not been established.
ETHERNET	ON	The Ethernet connection is active.
	OFF	No Ethernet device is detected.

Troubleshooting

LED Symptom	Action
All LEDs are on.	If the LEDs remain on for more than ten minutes, the RTU is not functional. Unplug the unit and reapply power. If the ALM LED is still on, contact the service provider.
ALM LED remains on.	The power-on self-test may have failed. Unplug the unit and reapply power. If the alarm light is still on, contact the service provider.
ALM and TST LEDs are blinking.	Firmware download may be in progress. If firmware download is not in progress or the LEDs continue blinking for more than ten minutes, contact the service provider. Do not unplug the unit, unless instructed to do so by the service provider.
DSL LED is off.	Verify that the DSL cable is securely installed on both ends. Unplug the unit and reapply power. If the problem continues, contact the service provider.
DSL LED continues to blink after the power-on self-test.	The RTU is attempting to establish the DSL link or adjusting the rate of the DSL line due to line conditions. If the DSL LED continues to blink for more than ten minutes, contact the service provider.
DSL LED is on and there is no data transmission.	The DSL link has been established but there is no data transmission. Verify the Ethernet connection. If the problem persists, contact the service provider.
DSL and Ethernet LEDs are on and there is no data transmission.	The DSL and the Ethernet links have been established but there is no data transmission. If the problem continues, contact the service provider.
Ethernet LED is off.	Verify that the Ethernet cable is securely installed at both ends, and that at least one PC is connected and powered on.
	Verify that the correct crossover cable is installed. Refer to <i>Installing the Hotwire 5216 RTU</i> on page 8.
PWR LED is off.	Check that the power cord is securely installed on both ends.
	If no LEDs are on, the power supply may be defective. Test the outlet to verify power. If the problem persists, contact the service provider.
	If other LEDs are on, the PWR light may be burned out. Unplug the unit and reapply power; watch all LEDs during the power-on self-test to verify that the PWR LED is functioning.
TST LED is on.	A test initiated by the service provider may be active. Wait ten minutes. If the TST LED does not go off, contact the service provider.

Cables & Connectors

Use standard twisted-pair CAT3 or better cables.

This section is reference information.

- **DSL interface** connector uses a 6-pin, non-keyed modular plug.

RJ11 6-Pin Connector

Pin #	Function
1 & 2	Not used
3	DSL Ring
4	DSL Tip
5 & 6	Not used

- **Ethernet interface** crossover cable connector uses an 8-pin, non-keyed modular plug.

DSL Cable

6-Pin RJ11 Plug

Pin #6

Pin #1

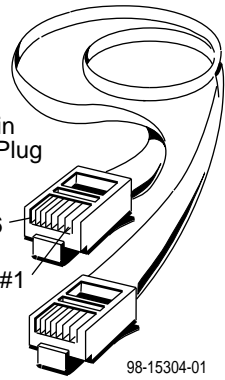

98-15304-01

Ethernet Cable

8-Pin Plug

Pin #8

Pin #1

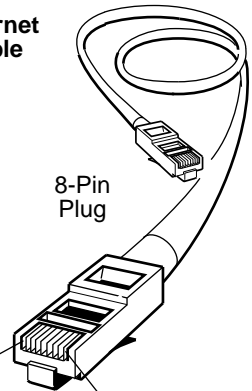

98-16055a

8-Pin Ethernet Crossover Cable

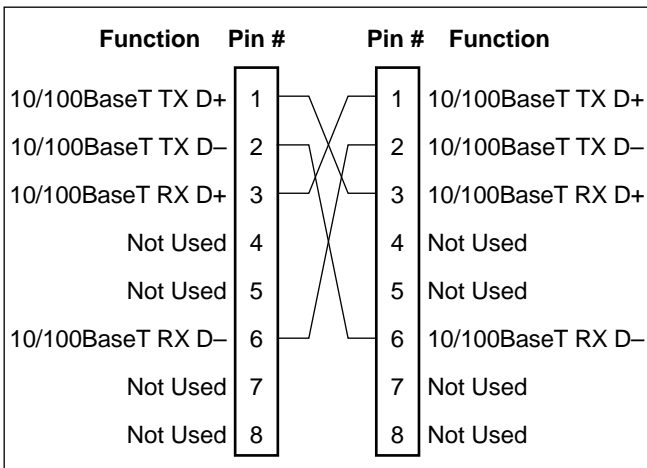

Pin #1/2 = Orange/White Twisted Pair

Pin #3/6 = Blue/White Twisted Pair

99-16518

Optional RTU Wall Placement

The Hotwire 5216 RTU is designed for tabletop placement. The RTU can also be mounted on a wall. To mount an RTU, you will need:

- Three slotted-head #6 self-threading screws with molly bolts
- Drill and 3/16" drill bit for the molly bolts
- Screwdriver

A template with the dimensions for the three screws is provided. See *RTU Hardware Template* on page 14.

► Procedure

To mount the RTU:

1. Use a drill to install the plastic anchors (molly bolts).
2. Use a screwdriver to install the screws. Do not install the screws flush with the wall. Leave enough clearance to hang the RTU housing from the screws.

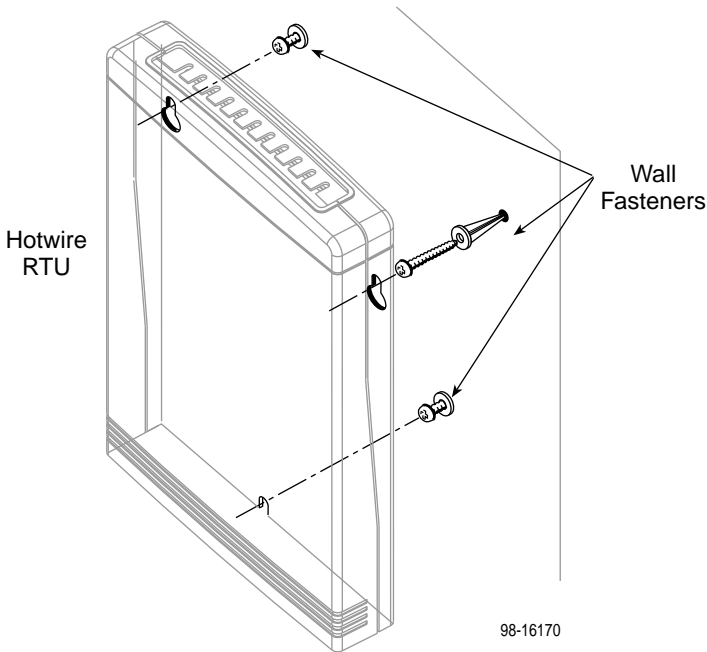

RTU Hardware Template

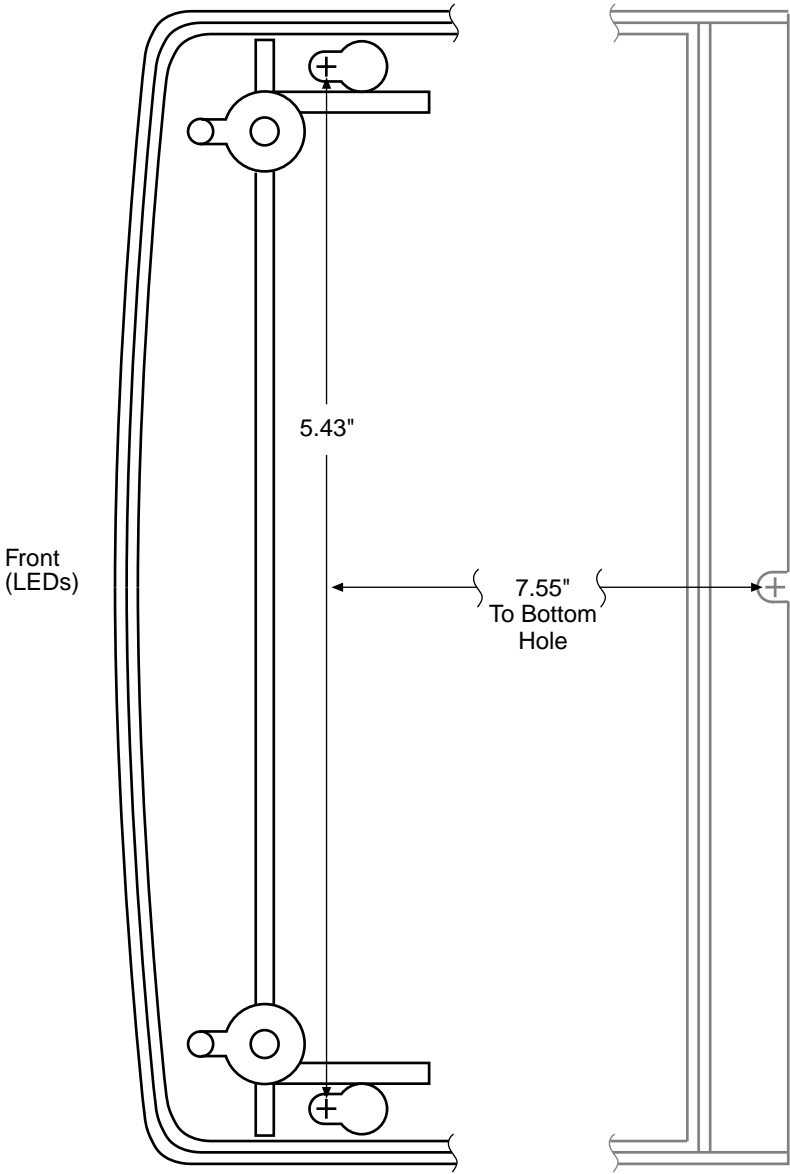

Technical Specifications for Model 5216 RTU

Item	Specification*
Height x Width x Depth	1.25" x 6.00" x 8.75" (3.18 cm x 15.24 cm x 22.23 cm)
Weight	1 lb. 1 oz. (0.48 kg)
Power Class 2 Transformer normal service input voltage range	Input: 100 VAC ($\pm 10\%$), 50 Hz; 120 VAC ($\pm 10\%$), 60 Hz; or 230 VAC ($\pm 10\%$), 50/60 Hz Output: 18 VDC nominal at 0.8A
Approvals FCC Part 15 CISPR 22 Safety Certifications	Class B Subpart B digital device Class B Refer to equipment's label for approvals on product.
Physical Environment Operating temperature Storage temperature Relative humidity Shock and vibration	32°F to 104°F (0°C to 40°C) -4°F to 158°F (-20°C to 70°C) 5% to 95% (noncondensing) Withstands normal shipping and handling
Heat Dissipation	40.9 Btu/hr. (max.) at nominal input voltage
Interface Connectors DSL Interface Ethernet Type II Frame	RJ11 6-pin 10BaseT 8-pin
* Technical Specifications subject to change without notification.	

▲ Important Safety Instructions

1. Read and follow all warning notices and instructions marked on the product or included in the manual.
2. Slots and openings in the cabinet are provided for ventilation. To ensure reliable operation of the product and to protect it from overheating, these slots and openings must not be blocked or covered.
3. Do not allow anything to rest on the power cord and do not locate the product where persons will walk on the power cord.
4. Do not attempt to service this product yourself, as opening or removing covers may expose you to dangerous high voltage points or other risks. Refer all servicing to qualified service personnel.
5. General purpose cables are used with this product for connection to the network. Special cables, which may be required by the regulatory inspection authority for the installation site, are the responsibility of the customer. Use a UL Listed, CSA certified, minimum No. 24 AWG line cord for connection to the Digital Subscriber Line (DSL) network.
6. When installed in the final configuration, the product must comply with the applicable Safety Standards and regulatory requirements of the country in which it is installed. If necessary, consult with the appropriate regulatory agencies and inspection authorities to ensure compliance.
7. A rare phenomenon can create a voltage potential between the earth grounds of two or more buildings. If products installed in separate buildings are **interconnected**, the voltage potential may cause a hazardous condition. Consult a qualified electrical consultant to determine whether or not this phenomenon exists and, if necessary, implement corrective action prior to interconnecting the products.
8. Input power to this product must be provided by one of the following: (1) a UL Listed/CSA certified power source with a Class 2 or Limited Power Source (LPS) output for use in North America, or (2) a certified transformer, with a Safety Extra Low Voltage (SELV) output having a maximum 240 VA available, for use in the country of installation.
9. In addition, since the equipment is to be used with telecommunications circuits, take the following precautions:
 - Never install telephone wiring during a lightning storm.
 - Never install telephone jacks in wet locations unless the jack is specifically designed for wet locations.
 - Never touch uninsulated telephone wires or terminals unless the telephone line has been disconnected at the network interface.
 - Use caution when installing or modifying telephone lines.
 - Avoid using a telephone (other than a cordless type) during an electrical storm. There may be a remote risk of electric shock from lightning.
 - Do not use the telephone to report a gas leak in the vicinity of the leak.

Declaration of Conformity

This Declaration of Conformity is made by Paradyne Corporation pursuant to Parts 2 and 15 of the Federal Communications Commission's Rules. This compliance information statement pertains to the following products:

Trade Name: Hotwire
Model Number: 5216-A3-200

This device complies with Part 15 of the FCC Rules. Operation is subject to the following two conditions: (1) this device may not cause harmful interference, and (2) this device must accept any interference received, including interference that may cause undesired operation.

The name, address, and telephone number of the responsible party is given below:

Paradyne Corporation
8545 126th Avenue North
Largo, FL 33773-1502
Phone: (727) 530-2000

The authority to operate this equipment is conditioned by the requirement that no modifications will be made to the equipment unless the changes or modifications are expressly approved by Paradyne Corporation.

Japan

Notices

この装置は、情報処理装置等電波障害自主規制協議会（VCCI）の基準に基づくクラス B 情報技術装置です。この装置は、家庭環境で使用することを目的としていますが、この装置がラジオやテレビジョン受信機に近接して使用されると、受信障害を引き起こすことがあります。
取扱説明書に従って正しい取り扱いをして下さい。

This is a Class B product based on the standard of the Voluntary Control Council for Interference from Information Technology Equipment (VCCI). If this is used near a radio or television receiver in a domestic environment, it may cause radio interference. Install and use the equipment according to the instruction manual.

CE Marking

When the product is marked with the CE mark on the equipment label, this demonstrates full compliance with the following European Directives:

- **Directive 73/23/EEC** – Council Directive of 19 February 1973 on the harmonization of the laws of the member states relating to electrical equipment designed for use within states relating to electrical equipment designed for use within certain voltage limits, as amended by Directive 93/68/EEC.
- **Directive 89/336/EEC** – Council Directive of 3 May 1989 on the approximation of the laws of the member states relating to Electro-Magnetic Compatibility (EMC), as amended by Directive 93/68/EEC.

CANADA – EMI NOTICE:

This Class B digital apparatus meets all requirements of the Canadian interference-causing equipment regulations.

Cet appareil numérique de la classe B respecte toutes les exigences du règlement sur le matériel brouilleur du Canada.

Government Requirements

Certain governments require that instructions pertaining to connection to the telephone network be included in the installation and operation manual. Specific instructions are listed in the following sections.

United States – Notice to Users of the Telephone Network

1. This equipment complies with Part 68 of the FCC rules. On the equipment is a label that contains, among other information, the FCC registration number and Ringer Equivalence Number (REN) for this equipment. The label is located on the bottom of your RTU.
2. The Hotwire 5216 RTU connects to the Public Switched Telephone Network (PSTN) using the Universal Service Order Code (USOC) RJ11C or RJ14C.
3. The Ringer Equivalence Number (REN) is used to determine the quantity of devices which may be connected to the telephone line. Excessive RENs on the telephone line may result in the devices not ringing in response to an incoming call. In most, but not all areas, the sum of the RENs should not exceed five (5.0). To be certain of the number of devices that may be connected to the line, as determined by the total RENs, contact the telephone company to determine the maximum RENs for the calling area.
4. If the RTU causes harm to the telephone network, the telephone company will notify you in advance that temporary discontinuance of service may be required. But if advance notice is not practical, the telephone company will notify the customer as soon as possible. Also, you will be advised of your right to file a complaint with the FCC if you believe it is necessary.

-
5. The telephone company may make changes in its facilities, equipment, operations, or procedures that could affect the operation of the equipment. If this happens, the telephone company will provide advance notice in order for you to make the necessary modifications in order to maintain uninterrupted service.
 6. If you experience trouble with this equipment, please contact your sales or service representative (as appropriate) for repair or warranty information. If the product needs to be returned to the company service center for repair, contact them directly for return instructions using one of the following methods:
 - **Internet:** Visit the Paradyne World Wide Web site at www.paradyne.com. (Be sure to register your warranty at www.paradyne.com/warranty.)
 - **Telephone:** Call our automated system to receive current information via fax or to speak with a company representative.
 - Within the U.S.A., call 1-800-870-2221
 - Outside the U.S.A., call 1-727-530-2340

If the trouble is causing harm to the telephone network, the telephone company may request that you remove the equipment from the network until the problem is resolved.

7. The user is not authorized to repair or modify the equipment.
8. This equipment cannot be used on public coin service provided by the telephone company. Connection to Party Line Service is subject to state tariffs. (Contact the state public utility commission, public service commission or corporation commission for information.)
9. An FCC compliant telephone cord with modular plugs may be provided with this equipment. This equipment is designed to be connected to the telephone network or premises wiring using a compatible modular jack which is Part 68 compliant.

Notice to Users of the Canadian Telephone Network

The Industry Canada label identifies certified equipment. This certification means that the equipment meets telecommunications network protective, operational and safety requirements as prescribed in the appropriate Terminal Equipment Technical Requirements document(s). The Department does not guarantee the equipment will operate to the user's satisfaction.

Before installing this equipment, users should ensure that it is permissible to be connected to the facilities of the local telecommunications company. The equipment must also be installed using an acceptable method of connection. The customer should be aware that compliance with the above conditions may not prevent degradation of service in some situations.

Repairs to certified equipment should be coordinated by a representative designated by the supplier. Any repairs or alterations made by the user to this equipment, or equipment malfunctions, may give the telecommunications company cause to request to disconnect the equipment.

Users should ensure for their own protection that the electrical ground connections of the power utility, telephone lines and internal metallic water pipe system, if present, are connected together. This precaution may be particularly important in rural areas.

CAUTION:

Users should not attempt to make such connections themselves, but should contact the appropriate electric inspection authority, or electrician, as appropriate.

The Ringer Equivalence Number (REN) assigned to each terminal device provides an indication of the maximum number of terminals allowed to be connected to a telephone interface. The termination on an interface may consist of any combination of devices subject only to the requirement that the sum of the Ringer Equivalence Numbers of all the devices does not exceed 5.

If your equipment is in need of repair, refer to *Warranty, Sales, Service, and Training Information*.

Warranty, Sales, Service, and Training Information

Contact your local sales representative, service representative, or distributor directly for any help needed. For additional information concerning warranty, sales, service, repair, installation, documentation, training, distributor locations, or Paradyne worldwide office locations, use one of the following methods:

- **Internet:** Visit the Paradyne World Wide Web site at www.paradyne.com. (Be sure to register your warranty at www.paradyne.com/warranty.)
- **Telephone:** Call our automated system to receive current information by fax or to speak with a company representative.
 - Within the U.S.A., call 1-800-870-2221
 - Outside the U.S.A., call 1-727-530-2340

Document Feedback

We welcome your comments and suggestions about this document. Please mail them to Technical Publications, Paradyne Corporation, 8545 126th Ave. N., Largo, FL 33773, or send e-mail to userdoc@paradyne.com. Include the number and title of this document in your correspondence. Please include your name and phone number if you are willing to provide additional clarification.

Trademarks

Hotwire is a registered trademark of Paradyne Corporation. All other products and services mentioned herein are the trademarks, service marks, registered trademarks or registered service marks of their respective owners.



5216-A2-GN10-30

Copyright © 2000 Paradyne Corporation. Printed in U.S.A.