

## Hotwire® 5620 RTU Installation Instructions

Document Number 5620-A2-GN11-40

September 2001

---

### Contents

Hotwire 5620 RTU Overview .....	1
Product Documentation Online .....	4
Getting Started .....	5
Installing the DSL Access Wiring .....	6
Connecting to the DSL Access Wiring .....	8
Installing the Hotwire 5620 RTU .....	9
Power-On .....	13
Troubleshooting .....	14
Increasing the Number of End-User Systems .....	15
Cables & Connectors .....	15
Optional RTU Wall Placement .....	17
Technical Specifications for the Hotwire 5620 RTU .....	19
Important Safety Instructions .....	20
Government Requirements .....	22
Warranty, Sales, Service, and Training Information .....	24

### Hotwire 5620 RTU Overview

The Hotwire® 5620 RTU (Remote Termination Unit) is a component in the Hotwire RADSL Access System and interoperates with the Hotwire 8373, 8374, or 8510 DSL Card in the DSLAM (Digital Subscriber Line Access Multiplexer) system. This system provides high-speed Internet or corporate LAN access over traditional twisted-pair copper telephone wiring.

Copper pairs run from the central office (CO) to the customer premises (CP) to create the local loop. The local loop terminates on the customer premises at the demarcation point in a punchdown block or network interface device (NID).

**NOTE:**

In this document:

- End-user system is used to represent any host with an Ethernet connection.
- Service provider is used to represent any Internet Service Provider (ISP) or remote LAN access provider.

**DSL Access with a Hotwire 5030 POTS Splitter**

An optional POTS (plain old telephone service) splitter can be installed to block out the DSL signal and allow the POTS frequencies to pass through. At the customer premises, the Hotwire 5620 RTU and a telephone can function simultaneously over the same pair of copper wires when a Hotwire 5030 POTS Splitter is installed near the demarcation point for all telephones on the same POTS line as DSL.

When a Hotwire 5030 POTS splitter is used at both ends of the local loop, wiring is connected:

- From the demarcation point to the CP POTS splitter, and
- From the demarcation point to the DSL jack.

The Hotwire 5030 POTS Splitter is designed for outdoor or indoor installation.

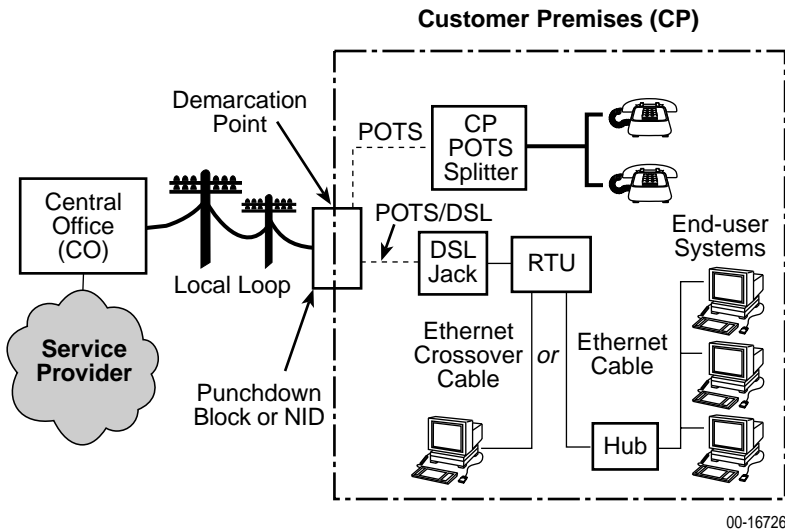

DSL – Digital Subscriber Line  
NID – Network Interface Device

POTS – Plain Old Telephone Service  
RTU – Remote Termination Unit

----- New Wiring Connections      — Existing Wiring (POTS)

## DSL Access without a POTS Splitter

When the Hotwire 5620 RTU is installed without a POTS splitter, the DSL line is used for data only and does not provide telephone services.

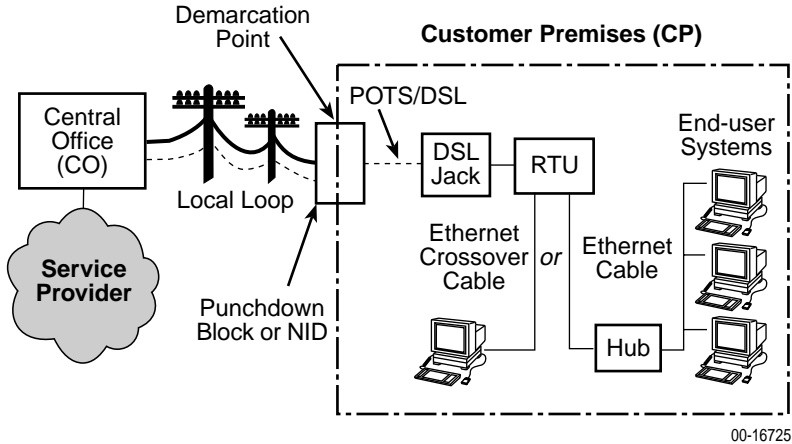

DSL – Digital Subscriber Line      RTU – Remote Termination Unit  
 NID – Network Interface Device      ----- New Wiring Connections

## Phone Filters

For optimum performance, if the wiring for the RTU is also used for voice (POTS), a phone filter should be installed on each voice line with a phone, modem, fax machine, or other telecommunications device attached. One Hotwire phone filter can be used with multiple telecommunications devices (for example, a phone and fax machine can be supported using a single filter) if a multiple line adapter is used.

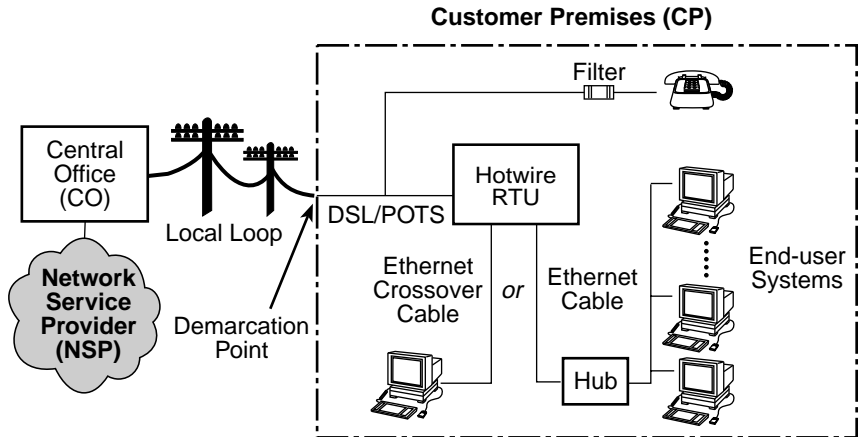

DSL – Digital Subscriber Lines  
 POTS – Plain Old Telephone Service

There are two Hotwire phone filters that can be used with the 5620 RTU:

- Hotwire 6035 Universal Phone Filter is designed for use with a tabletop phone.
- Hotwire 6040 Universal Wall Jack Phone Filter is designed for use with a wall phone.

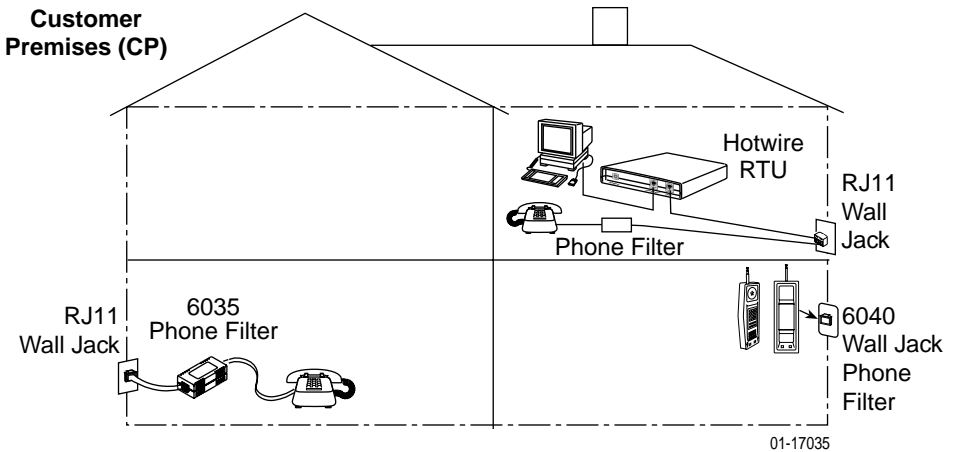

If installing the router on the wall instead of a table or desk, refer to [Optional RTU Wall Placement](#) on page 17 before installing the router and cables.

## Product Documentation Online

Complete documentation for this product is available at [www.paradyne.com](http://www.paradyne.com).  
Select *Library* → *Technical Manuals* → *Hotwire DSL Systems*.

To install a POTS splitter or phone filter, refer to the appropriate document:

Document Number	Document Title
5030-A2-GN10	<i>Hotwire 5030 POTS Splitter Customer Premises Installation Instructions</i>
6035-A2-GN11	<i>Hotwire 6035 Universal Phone Filter Installation Instructions</i>
6040-A2-GN11	<i>Hotwire 6040 Universal Wall Jack Phone Filter Installation Instructions</i>

---

# Getting Started

Before beginning your RTU's installation, make sure that you have all the equipment you will need.

## Package Checklist

In addition to these instructions, verify that your package contains the following:

- Model 5620 Remote Termination Unit (RTU)
- DSL interface cable with RJ11 modular plugs
- Power cord with power transformer

## Wiring and Connectors You Will Need

The following wiring and standard connectors are used with this product:

- Standard RJ11 wall jack for the DSL cabling.
- Multiple line adapter if a telephone and RTU are connected in the same location.
- DSL cabling: New or existing unshielded twisted-pair wiring (CAT3 or better). The CAT3 wiring must meet EIA/TIA-568 specifications with 24 AWG (.5 mm) or 26 AWG (.4 mm).
- Ethernet cabling: Standard Ethernet 8-pin, non-keyed modular plug for a PC or workstation. An Ethernet straight-through or crossover cable is used. Refer to procedures in *Installing the Hotwire 5620 RTU* on page 9 for Ethernet cable details.

Refer to *Cables & Connectors* on page 15 for standard pin numbers.

# Installing the DSL Access Wiring

The local loop terminates at the punchdown block or NID. Wiring must be connected from the customer premises side of the punchdown block or the NID to an RJ11 jack. Typically, the punchdown block is installed in commercial locations and the NID is installed in residential locations.

## ► Procedure

1. Access the punchdown block or NID.
2. Disconnect the DSL access pair from the local loop.

## ⚠ WARNING:

**Do not continue unless the DSL access line from the local loop has been disconnected at the NID or punchdown block. Refer to [Important Safety Instructions](#) on page 20.**

A punchdown block is used without a POTS splitter in the following example.

### Punchdown Block

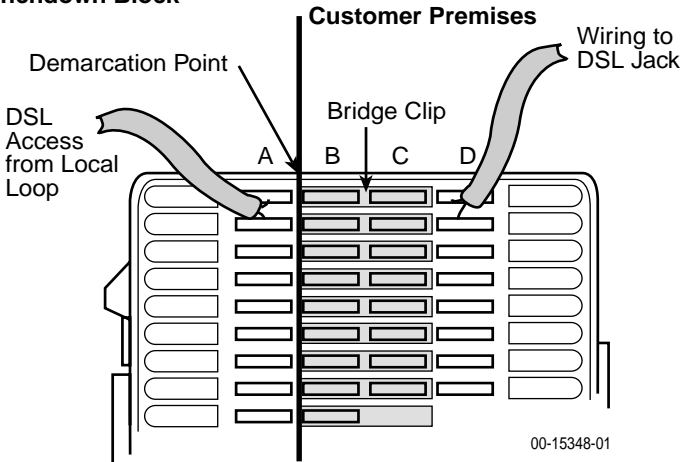

3. Locate the DSL pair of T1/R1 connectors on the customer premises side of the NID or punchdown block. Attach the wiring that will be connected to the DSL jack.

In the following example, a NID is used without a POTS splitter. It includes an existing POTS line and a second pair installed for DSL access.

### Telephone Network Interface Device (NID)

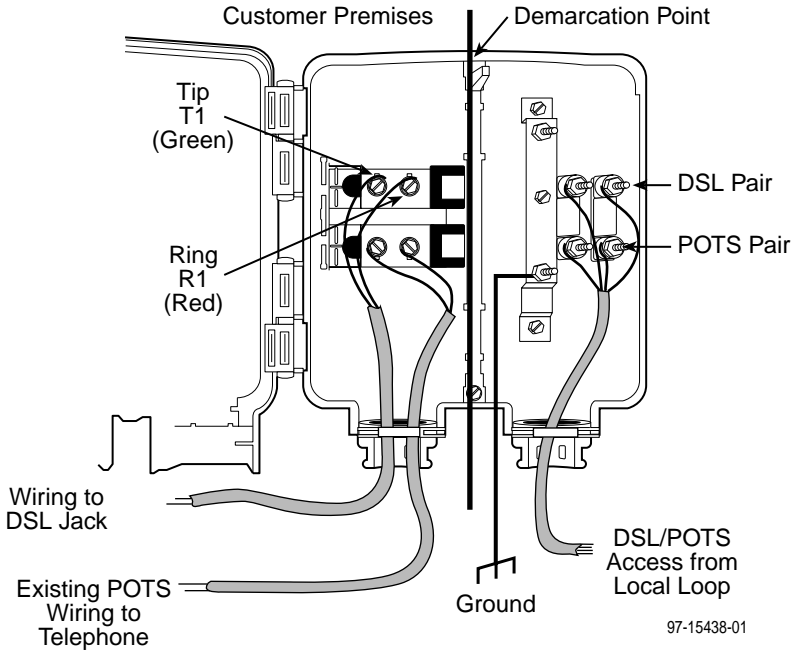

# Connecting to the DSL Access Wiring

The Hotwire 5620 RTU connects to the local loop via wiring from the demarcation point to an RJ11 wall jack. The DSL twisted-pair wiring from the local loop terminates at a new or existing wall jack. It may be necessary to install a standard single RJ11 jack or replace a single jack with a double RJ11 jack.

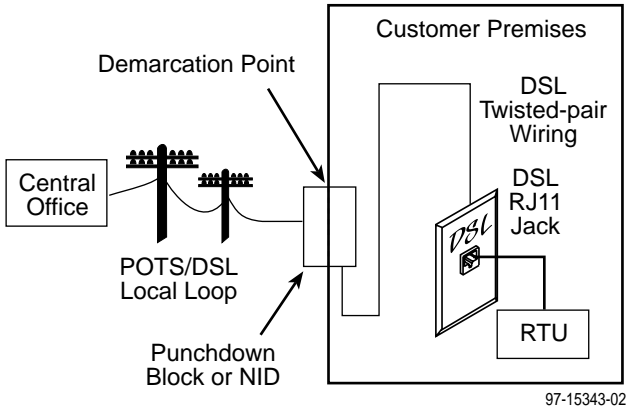

## ► Procedure

1. Wiring can be run from the punchdown block or NID to a new or existing wall jack. Match the pair colors on both ends.
2. Label the DSL jack.
3. Reconnect the DSL access pair at the punchdown block or NID. Refer to [Installing the DSL Access Wiring](#) on page 6. Tighten both terminal screws with a flat-blade screwdriver.

### RJ11 Wall Jack

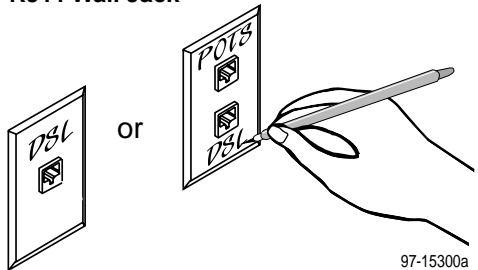

The RJ11 6-pin jack uses the center two pins. For pin assignments, refer to [Cables & Connectors](#) on page 15.

---

# Installing the Hotwire 5620 RTU

Place the Hotwire 5620 RTU on a flat surface with clearance for the rear connectors.

## Connecting the DSL Line in a Home Environment (Phone and RTU in the Same Location)

Use the supplied RJ11 6-pin cable for the DSL connection. You will also need a multiple line adapter and a phone filter (see [Phone Filters](#) on page 3).

### ► Procedure

1. Insert a multiple line adapter into the wall jack.
2. Insert one end of the cable into the **DSL** jack on the RTU.
3. Insert the other end of the cable into one of the jacks (**Line 1** or **Line 2**) on the multiple line adapter.
4. Insert the line cord from the **LINE** jack on the filter into the empty jack on the multiple line adapter.
5. Insert the phone line cord from the phone into the **PHONE** jack on the filter.

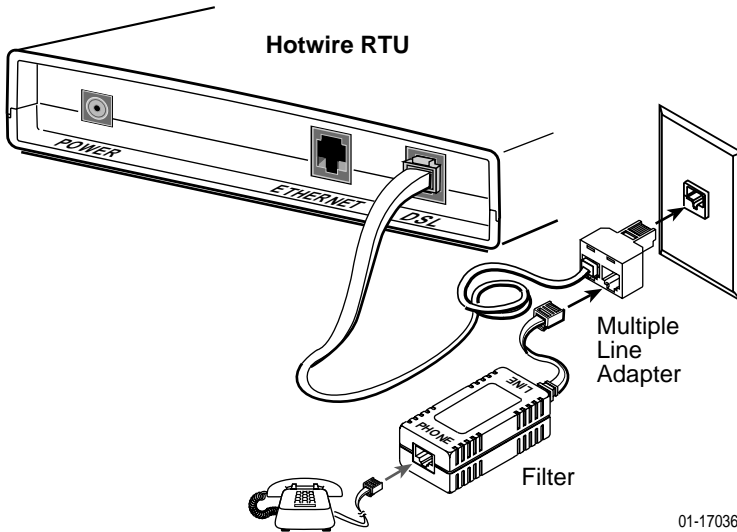

01-17036

---

## Connecting the DSL Line in All Other Environments

Use the supplied RJ11 6-pin cable for the DSL connection.

### ► Procedure

1. Insert one end of the cable into the **DSL** jack on the RTU.
2. Insert the other end into the wall jack.

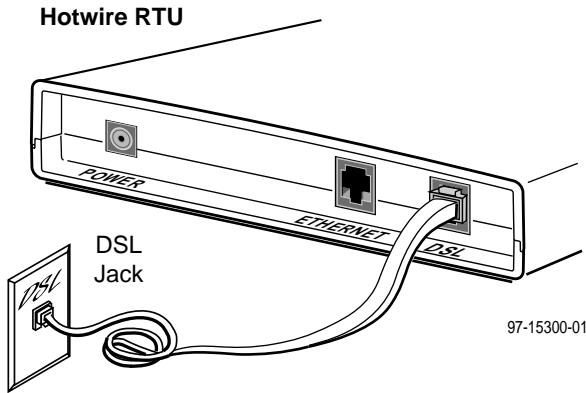

## Connecting the Ethernet Cable

Use an 8-pin Ethernet straight-through or crossover cable for the Ethernet connection.

### ► Procedure

To connect an Ethernet Hub using a straight-through cable:

- Insert one end of the straight-through cable into the **ETHERNET** jack on the router and connect the other end to an Ethernet hub. Do not connect it to the hub's optional Uplink connection; the Uplink connection requires an Ethernet crossover cable. To support multiple end-user systems, refer to [Increasing the Number of End-User Systems](#) on page 15.

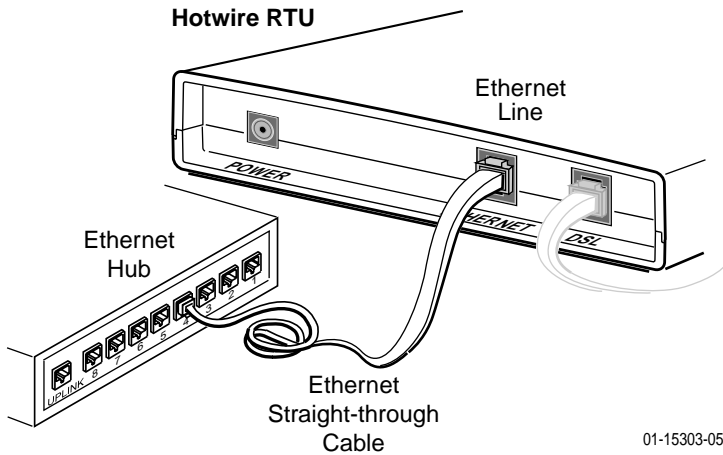

To connect a PC using a crossover cable:

- Insert one end of the crossover cable into the **ETHERNET** jack on the router and connect the other end of the cable to a PC with an Ethernet Network Interface Card (NIC) installed.

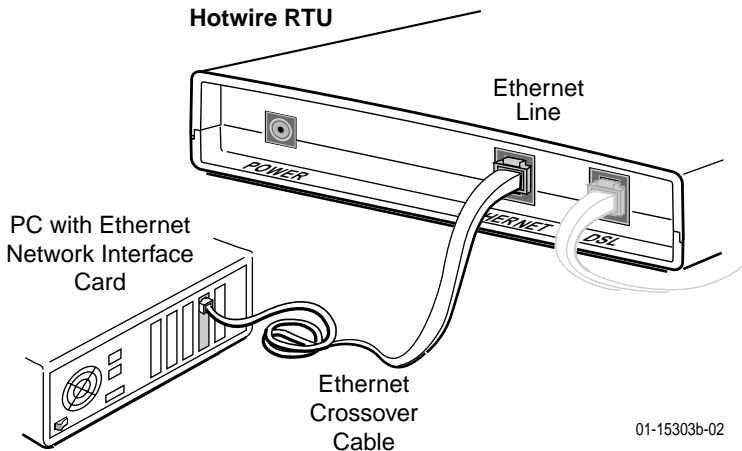

---

## Connecting Power

### ► Procedure

1. Insert the supplied power cord's round end into the **POWER** jack on the RTU.
2. Plug the transformer into an AC outlet.

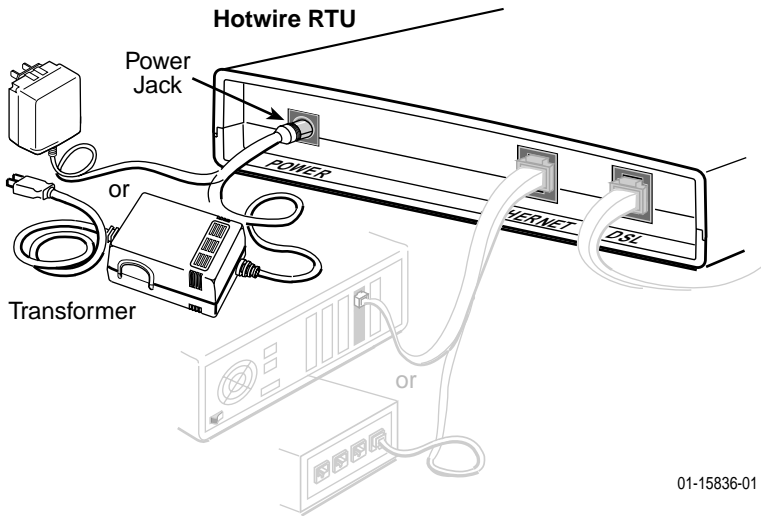

01-15836-01

The RTU hardware installation is now complete. When the power cord is installed, the RTU goes through a power-on self-test.

# Power-On

When power is applied, the RTU performs self-diagnostics and the PWR LED is on. The self-diagnostics includes a power-on self-test. During the power-on self-test, all of the LEDs turn on for one second.

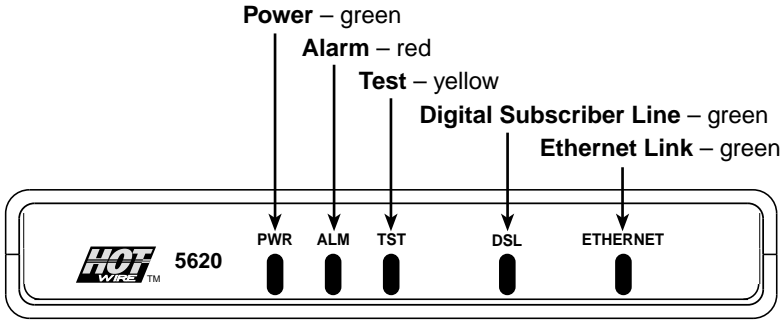

98-15835

## Status LEDs

All of the LEDs turn on and off during the power-on self-test. After a successful self-test, the LEDs should appear as indicated in **BOLD** in the Condition column below.

LED	Condition	Status
PWR	<b>ON</b>	The RTU has power.
ALM	<b>OFF</b>	No active alarms.
	<b>ON</b>	An alarm condition exists.
TST	<b>OFF</b>	No active tests.
	<b>ON</b>	The TST LED is on during the power-on self-test and during a test initiated by the service provider.
DSL	Blinking	The RTU is establishing the active DSL link. The LED blinks on and off about five times per second.
	<b>ON</b>	The DSL link is ready to transmit and receive data.
	<b>OFF</b>	The DSL link has not been established.
ETHERNET	<b>ON</b>	The Ethernet connection is active.
	<b>OFF</b>	No Ethernet device is detected.

Refer to [Troubleshooting](#) on page 14 for LED indications requiring action.

# Troubleshooting

LED Symptom	Action
All LEDs are on.	If the LEDs remain on for more than ten minutes, the RTU is not functional. Unplug the unit and reapply power. If the ALM LED is still on, contact the service provider.
ALM LED remains on.	The power-on self-test may have failed. Unplug the unit and reapply power. If the alarm LED is still on, contact the service provider.
ALM and TST LEDs are blinking.	Firmware download may be in progress. If firmware download is not in progress or the LEDs continue blinking for more than ten minutes, contact the service provider. Do not unplug the unit, unless instructed to do so by the service provider.
DSL LED is off.	Verify that the DSL cable is securely installed on both ends. Unplug the unit and reapply power. If the problem continues, contact the service provider.
DSL LED continues to blink after the power-on self-test.	The RTU is attempting to establish the DSL link or adjusting the rate of the DSL line due to line conditions. If the DSL LED continues to blink for more than ten minutes, contact the service provider.
DSL LED is on and there is no data transmission.	The DSL link has been established but there is no data transmission. Verify the Ethernet connection. If the problem persists, contact the service provider.
DSL and Ethernet LEDs are on and there is no data transmission.	The DSL link and the Ethernet link have been established but there is no data transmission. If the problem continues, contact the service provider.
Ethernet LED is off.	Verify that the Ethernet cable is securely installed at both ends, and at least one PC is connected and powered on.
	Verify that the correct straight-through or crossover cable is installed. Refer to <a href="#">Connecting the Ethernet Cable</a> on page 11.
PWR LED is off.	Check that the power cord is securely installed on both ends.
	If no LEDs are on, the power supply may be defective. Test the outlet to verify power. If the problem persists, contact the service provider.
	If other LEDs are on, the PWR LED may be burned out. Unplug the unit and reapply power; watch all LEDs during the power-on self-test to verify that the PWR LED is functioning.
TST LED is on.	A test initiated by the service provider may be active. Wait ten minutes. If the TST LED does not go off, contact the service provider.

# Increasing the Number of End-User Systems

A single end-user system is attached to the Hotwire 5620 RTU by using an Ethernet crossover cable. To increase the number of end-user systems, connect all end-user systems to an Ethernet hub using a straight-through cable. See [Connecting the Ethernet Cable](#) on page 11.

The Hotwire 5620 RTU can support up to 32 end-user systems. Verify any changes with the service provider.

## Cables & Connectors

This section is reference information.

Use standard twisted-pair CAT3 or better cables.

- **DSL interface** connector uses a 6-pin, non-keyed modular plug.

### RJ11 6-Pin Connector

Pin #	Function
1 & 2	Not used
3	DSL Ring
4	DSL Tip
5 & 6	Not used

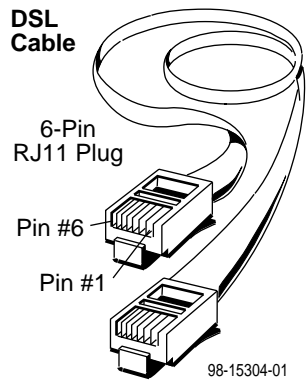

- **Ethernet interface** connector uses an 8-pin, non-keyed modular plug. Use shielded twisted-pair CAT5 or better cables.

- To connect to an Ethernet hub, use the straight-through connection.

**8-Pin Straight-through Connection**

Pin #	Function
1	10BaseT TX D+
2	10BaseT TX D-
3	10BaseT RX D+
4 & 5	Not used
6	10BaseT RX D-
7 & 8	Not used

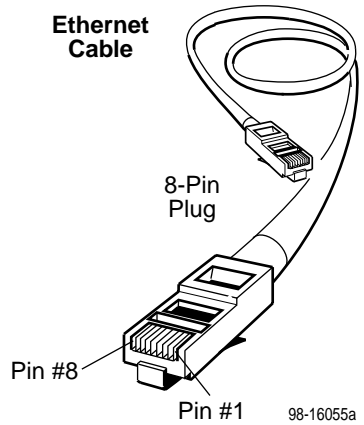

– or –

- To connect directly to a PC with an Ethernet NIC card, use an Ethernet Crossover cable.

**8-Pin Ethernet Crossover Cable**

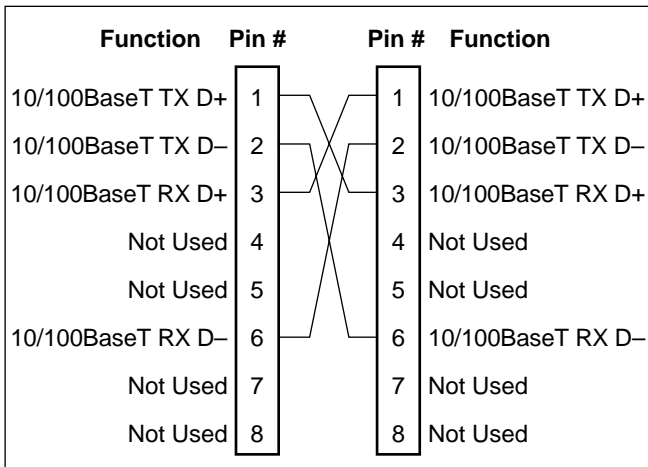

Pin #1/2 = Orange/White Twisted Pair

Pin #3/6 = Blue/White Twisted Pair

99-16518

# Optional RTU Wall Placement

The Hotwire 5620 RTU is designed for tabletop placement. The RTU can also be mounted on a wall.

To mount the RTU, you will need:

- Three #6 pan-head screws with anchors (for example, molly bolts, plastic or lead anchors)
- Drill, and the correct size drill bit for the anchors
- Screwdriver

A template with the dimensions for the three screws is provided. See [RTU Hardware Template](#) on page 18.

## ► Procedure

To mount the RTU:

1. Drill the correct size hole for the anchors and install them. Use the template to gauge their placement.
2. Screw the pan-head screws into the installed anchors. Do not make them flush with the wall. Leave enough clearance to hang the router housing from the screws.

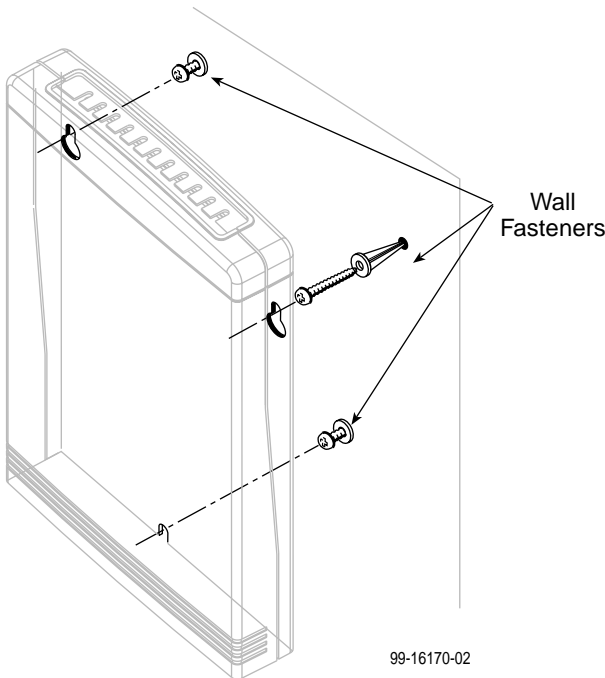

99-16170-02

# RTU Hardware Template

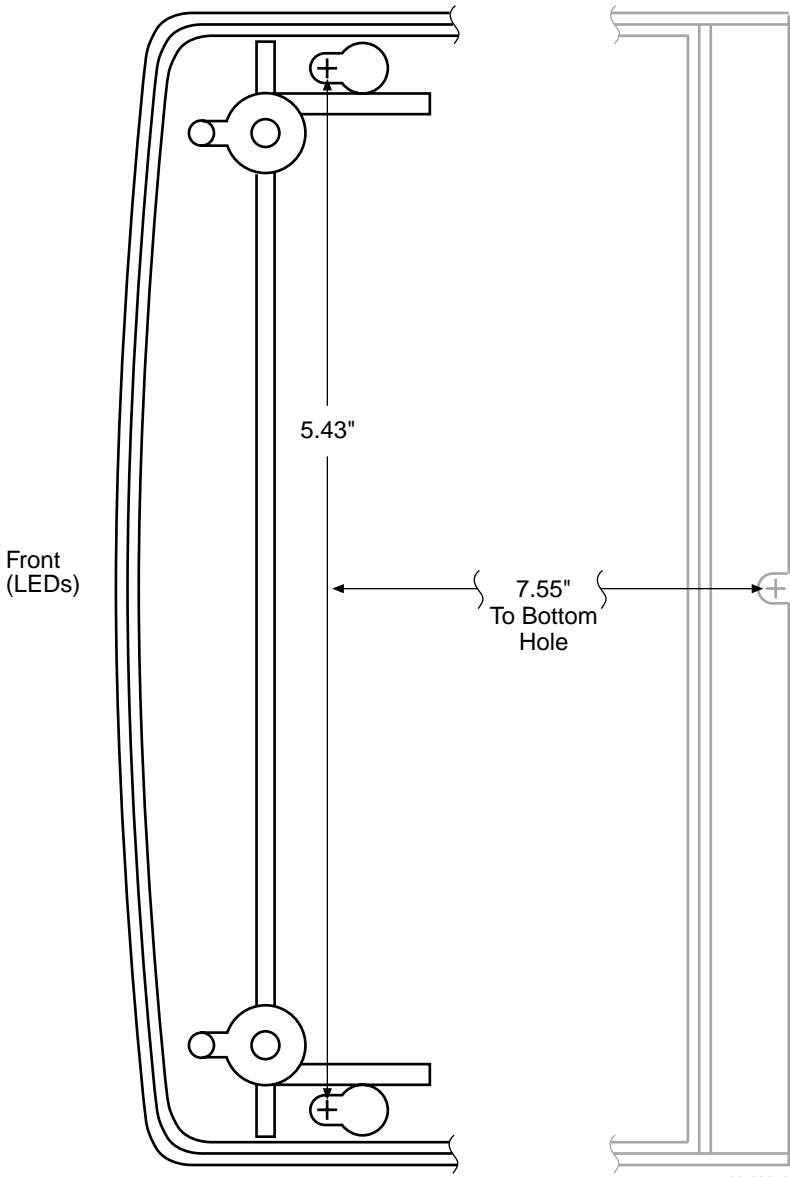

# Technical Specifications for the Hotwire 5620 RTU

Item	Specification*
<b>Height x Width x Depth</b> With Feet Without Feet	1.43" x 6.00" x 8.75" (3.64 cm x 15.24 cm x 22.23 cm) 1.25" x 6.00" x 8.75" (3.15 cm x 15.24 cm x 22.23 cm)
<b>Weight</b>	1 lb. 1 oz. (0.48 kg)
<b>Power</b> Class 2 Transformer normal service input voltage range	Input: 100 VAC ( $\pm 10\%$ ), 50 Hz; 120 VAC ( $\pm 10\%$ ), 60 Hz; or 230 VAC ( $\pm 10\%$ ), 50/60 Hz Output: 18 VDC nominal at 0.8A
<b>Approvals</b> FCC Part 15 CISPR 22 Safety Certifications	Class B Subpart B digital device Class B Refer to equipment's label for approvals on product.
<b>Physical Environment</b> Operating temperature Storage temperature Relative humidity Shock and vibration	32°F to 104°F (0°C to 40°C) -4°F to 158°F (-20°C to 70°C) 5% to 95% (noncondensing) Withstands normal shipping and handling
<b>Heat Dissipation</b>	40.9 Btu/hr. (max.) at nominal input voltage
<b>Interface Connectors</b> DSL Interface Ethernet Type II Frame	RJ11 6-pin 10BaseT 8-pin

\* Technical Specifications subject to change without notification.

---

## Important Safety Instructions

1. Read and follow all warning notices and instructions marked on the product or included in the manual.
2. Slots and openings in the cabinet are provided for ventilation. To ensure reliable operation of the product and to protect it from overheating, these slots and openings must not be blocked or covered.
3. Do not allow anything to rest on the power cord and do not locate the product where persons will walk on the power cord.
4. Do not attempt to service this product yourself, as opening or removing covers may expose you to dangerous high voltage points or other risks. Refer all servicing to qualified service personnel.
5. General purpose cables are used with this product for connection to the network. Special cables, which may be required by the regulatory inspection authority for the installation site, are the responsibility of the customer. Use a UL Listed, CSA certified, minimum No. 24 AWG line cord for connection to the Digital Subscriber Line (DSL) network.
6. When installed in the final configuration, the product must comply with the applicable Safety Standards and regulatory requirements of the country in which it is installed. If necessary, consult with the appropriate regulatory agencies and inspection authorities to ensure compliance.
7. A rare phenomenon can create a voltage potential between the earth grounds of two or more buildings. If products installed in separate buildings are **interconnected**, the voltage potential may cause a hazardous condition. Consult a qualified electrical consultant to determine whether or not this phenomenon exists and, if necessary, implement corrective action prior to interconnecting the products.
8. Input power to this product must be provided by one of the following: (1) a UL Listed/CSA certified power source with a Class 2 or Limited Power Source (LPS) output for use in North America, or (2) a certified transformer, with a Safety Extra Low Voltage (SELV) output having a maximum 240 VA available, for use in the country of installation.
9. In addition, since the equipment is to be used with telecommunications circuits, take the following precautions:
  - Never install telephone wiring during a lightning storm.
  - Never install telephone jacks in wet locations unless the jack is specifically designed for wet locations.
  - Never touch uninsulated telephone wires or terminals unless the telephone line has been disconnected at the network interface.
  - Use caution when installing or modifying telephone lines.
  - Avoid using a telephone (other than a cordless type) during an electrical storm. There may be a remote risk of electric shock from lightning.
  - Do not use the telephone to report a gas leak in the vicinity of the leak.

---

## CE Marking

When the product is marked with the CE mark on the equipment label, this demonstrates full compliance with the following European Directives:

- **Directive 73/23/EEC** – Council Directive of 19 February 1973 on the harmonization of the laws of the member states relating to electrical equipment designed for use within states relating to electrical equipment designed for use within certain voltage limits, as amended by Directive 93/68/EEC.
- **Directive 89/336/EEC** – Council Directive of 3 May 1989 on the approximation of the laws of the member states relating to Electro-Magnetic Compatibility (EMC), as amended by Directive 93/68/EEC.

## Japan – Notices

この装置は、情報処理装置等電波障害自主規制協議会（VCCI）の基準に基づくクラス B 情報技術装置です。この装置は、家庭環境で使用することを目的としていますが、この装置がラジオやテレビジョン受信機に近接して使用されると、受信障害を引き起こすことがあります。  
取扱説明書に従って正しい取り扱いをして下さい。

This is a Class B product based on the standard of the Voluntary Control Council for Interference from Information Technology Equipment (VCCI). If this is used near a radio or television receiver in a domestic environment, it may cause radio interference. Install and use the equipment according to the instruction manual.

## Declaration of Conformity

This Declaration of Conformity is made by Paradyne Corporation pursuant to Parts 2 and 15 of the Federal Communications Commission's Rules. This compliance information statement pertains to the following products:

Trade Name: Hotwire  
Model Number: 5620-A3-200

This device complies with Part 15 of the FCC Rules. Operation is subject to the following two conditions: (1) this device may not cause harmful interference, and (2) this device must accept any interference received, including interference that may cause undesired operation.

The name, address, and telephone number of the responsible party is given below:

Paradyne Corporation  
8545 126th Avenue North  
Largo, FL 33773-1502  
Phone: (727) 530-2000

---

The authority to operate this equipment is conditioned by the requirement that no modifications will be made to the equipment unless the changes or modifications are expressly approved by Paradyne Corporation.

This equipment has been tested and found to comply with the limits for a Class B digital device, pursuant to Part 15 of the FCC Rules. These limits are designed to provide reasonable protection against harmful interference in a residential installation. This equipment generates, uses, and can radiate radio frequency energy and, if not installed and used in accordance with the instructions, may cause harmful interference to radio communications. However, there is no guarantee that interference will not occur in a particular installation. If this equipment does cause harmful interference to radio or television reception, which can be determined by turning the equipment off and on, the user is encouraged to try to correct the interference by one or more of the following measures:

- Reorient or relocate the receiving antenna.
- Increase the separation between the equipment and receiver.
- Connect the equipment into an outlet on a circuit different from that to which the receiver is connected.
- Consult the dealer or an experienced radio/TV technician for help.

 **CANADA – EMI NOTICE:**

**This Class B digital apparatus meets all requirements of the Canadian interference-causing equipment regulations.**

**Cet appareil numérique de la classe B respecte toutes les exigences du règlement sur le matériel brouilleur du Canada.**

## **Government Requirements**

Certain governments require that instructions pertaining to connection to the telephone network be included in the installation and operation manual. Specific instructions are listed in the following sections.

### **United States – Notice to Users of the Telephone Network**

1. This equipment complies with Part 68 of the FCC rules. On the equipment is a label that contains, among other information, the FCC registration number and Ringer Equivalence Number (REN) for this equipment. The label is located on the bottom of your RTU.
2. The Hotwire 5620 RTU connects to the Public Switched Telephone Network (PSTN) using the Universal Service Order Code (USOC) RJ11C or RJ14C.
3. The Ringer Equivalence Number (REN) is used to determine the quantity of devices which may be connected to the telephone line. Excessive RENs on the telephone line may result in the devices not ringing in response to an incoming call. In most, but not all areas, the sum of the RENs should not exceed five (5.0). To be certain of the number of devices that may be connected to the line, as determined by the total RENs, contact the telephone company to determine the maximum RENs for the calling area.

- 
4. If the RTU causes harm to the telephone network, the telephone company will notify you in advance that temporary discontinuance of service may be required. But if advance notice is not practical, the telephone company will notify the customer as soon as possible. Also, you will be advised of your right to file a complaint with the FCC if you believe it is necessary.
  5. The telephone company may make changes in its facilities, equipment, operations, or procedures that could affect the operation of the equipment. If this happens, the telephone company will provide advance notice in order for you to make the necessary modifications in order to maintain uninterrupted service.
  6. If you experience trouble with this equipment, please contact your sales or service representative (as appropriate) for repair or warranty information. If the product needs to be returned to the company service center for repair, contact them directly for return instructions using one of the following methods:
    - **Internet:** Visit the Paradyne World Wide Web site at **www.paradyne.com**.
    - **Telephone:** Call our automated system to receive current information via fax or to speak with a company representative.  
Within the U.S.A., call 1-800-870-2221  
Outside the U.S.A., call 1-727-530-2340

If the trouble is causing harm to the telephone network, the telephone company may request that you remove the equipment from the network until the problem is resolved.

7. The user is not authorized to repair or modify the equipment.
8. This equipment cannot be used on public coin service provided by the telephone company. Connection to Party Line Service is subject to state tariffs. (Contact the state public utility commission, public service commission or corporation commission for information.)
9. An FCC compliant telephone cord with modular plugs may be provided with this equipment. This equipment is designed to be connected to the telephone network or premises wiring using a compatible modular jack which is Part 68 compliant.

## **Notice to Users of the Canadian Telephone Network**

The Industry Canada label identifies certified equipment. This certification means that the equipment meets telecommunications network protective, operational and safety requirements as prescribed in the appropriate Terminal Equipment Technical Requirements document(s). The Department does not guarantee the equipment will operate to the user's satisfaction.

Before installing this equipment, users should ensure that it is permissible to be connected to the facilities of the local telecommunications company. The equipment must also be installed using an acceptable method of connection. The customer should be aware that compliance with the above conditions may not prevent degradation of service in some situations.

Repairs to certified equipment should be coordinated by a representative designated by the supplier. Any repairs or alterations made by the user to this equipment, or equipment malfunctions, may give the telecommunications company cause to request to disconnect the equipment.

---

Users should ensure for their own protection that the electrical ground connections of the power utility, telephone lines and internal metallic water pipe system, if present, are connected together. This precaution may be particularly important in rural areas.

**CAUTION:**

**Users should not attempt to make such connections themselves, but should contact the appropriate electric inspection authority, or electrician, as appropriate.**

The Ringer Equivalence Number (REN) assigned to each terminal device provides an indication of the maximum number of terminals allowed to be connected to a telephone interface. The termination on an interface may consist of any combination of devices subject only to the requirement that the sum of the Ringer Equivalence Numbers of all the devices does not exceed 5.

If your equipment is in need of repair, refer to *Warranty, Sales, Service, and Training Information* on page 24.

## Warranty, Sales, Service, and Training Information

Contact your local sales representative, service representative, or distributor directly for any help needed. For additional information concerning warranty, sales, service, repair, installation, documentation, training, distributor locations, or Paradyne worldwide office locations, use one of the following methods:

- **Internet:** Visit the Paradyne World Wide Web site at [www.paradyne.com](http://www.paradyne.com).  
(Be sure to register your warranty at [www.paradyne.com/warranty](http://www.paradyne.com/warranty).)
- **Telephone:** Call our automated system to receive current information by fax or to speak with a company representative.
  - Within the U.S.A., call 1-800-870-2221
  - Outside the U.S.A., call 1-727-530-2340

## Document Feedback

We welcome your comments and suggestions about this document. Please mail them to Technical Publications, Paradyne Corporation, 8545 126th Ave. N., Largo, FL 33773, or send e-mail to [userdoc@paradyne.com](mailto:userdoc@paradyne.com). Include the number and title of this document in your correspondence. Please include your name and phone number if you are willing to provide additional clarification.

## Trademarks

Hotwire is a registered trademark of Paradyne Corporation. All other products and services mentioned herein are the trademarks, service marks, registered trademarks, or registered service marks of their respective owners.



\*5620-A2-GN11-40\*