

## Hotwire® 6341/6342 SDSL Routers Installation Instructions

Document Number 6341-A2-GN10-20

March 2001

---

### Contents

Hotwire 6341/6342 SDSL Routers Overview .....	1
Product Documentation Online .....	3
Package Checklist .....	3
Wiring and Cables You Will Need .....	4
Installing DSL Access Wiring .....	5
Connecting to the DSL Access Wiring .....	6
Installing the Hotwire 6341/6342 SDSL Router .....	7
Power-On .....	10
Status LEDs .....	11
Troubleshooting .....	12
Configuration Setup .....	13
SDSL Router Technical Specifications .....	19
Cables and Connectors .....	14
Optional Wall Placement .....	17
Important Safety Instructions .....	20
Government Requirements .....	21
Warranty, Sales, Service, and Training Information .....	24

### Hotwire 6341/6342 SDSL Routers Overview

Hotwire® 6341 and 6342 SDSL (Symmetric Digital Network Digital Subscriber Line) Routers are components in the Hotwire DSLAM (Digital Subscriber Line Access Multiplexer) system.

- Hotwire 6341 SDSL Router with one Ethernet port
- Hotwire 6342 SDSL Router with a 4-port Ethernet hub

Both Hotwire SDSL Routers interoperate with either the Hotwire 8343 or 8344 SDSL Line Card.

Both the Hotwire SDSL Routers operate as IP routers, connecting a DSL link to an Ethernet network to provide high-speed Internet or corporate LAN access over traditional twisted-pair copper telephone wiring. These packet-based products are configurable from 144 kbps up to 2.3 Mbps.

**Network with a Hotwire 6341 SDSL Router**

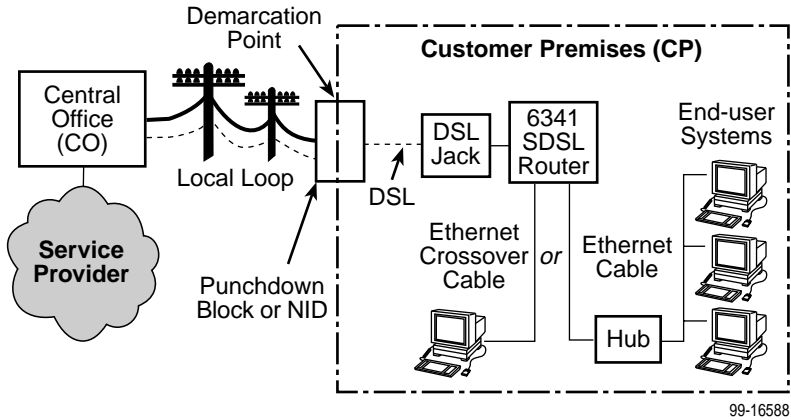

DSL – Digital Subscriber Line      - - - - - New Wiring Connections  
 NID – Network Interface Device

**Network with a Hotwire 6342 SDSL Router**

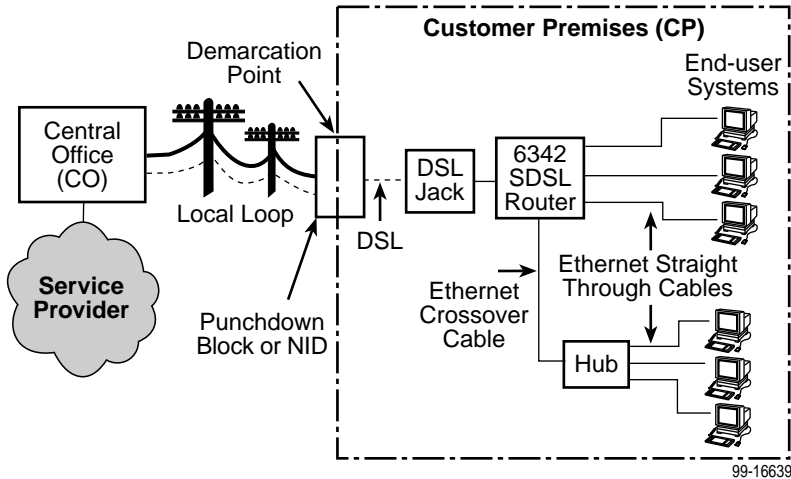

DSL – Digital Subscriber Line      - - - - - New Wiring Connections  
 NID – Network Interface Device

---

Copper pairs run from the central office to the customer premises to create the local loop. The local loop terminates on the customer premises at the demarcation point in a punchdown block or network interface device (NID).

If installing the router on the wall instead of a table or desk, refer to [Optional Wall Placement](#) on page 17 before installing the router and cables.

**NOTE:**

In this document:

- End-user system is used to represent any host with an Ethernet connection.
- Service provider is used to represent any Internet Service Provider (ISP) or remote LAN provider.

## Product Documentation Online

Complete documentation for this product is available at [www.paradyne.com](http://www.paradyne.com).  
Select *Library* → *Technical Manuals* → *Hotwire DSL and MVL Systems*.

Select the following document:

6371-A2-GB20  
*Hotwire DSL Routers User's Guide*

To order a paper copy of a Paradyne document:

- Within the U.S.A., call 1-800-PARADYNE (1-800-727-2396)
- Outside the U.S.A., call 1-727-530-8623

## Package Checklist

In addition to these instructions, verify that your package contains the following:

- Hotwire 6341 or 6342 SDSL Router
- DSL interface cable with RJ11 modular plugs
- Power cord with power transformer

---

## Wiring and Cables You Will Need

The following wiring and standard connectors are used with this product:

- Standard RJ11 wall jack for the DSL cable.
- DSL wiring: Unshielded twisted-pair wiring (CAT3, or better). The CAT3 wiring must meet EIA/TIA-568 specifications, with 24 AWG (.5 mm) or 26 AWG (.4 mm).
- Ethernet wiring: Shielded twisted-pair wiring (CAT5, or better). The CAT5 wiring must meet EIA/TIA-568 specifications, with 24 AWG (.5 mm) or 26 AWG (.4 mm). A straight-through or crossover Ethernet cable is used.

Refer to [Installing the Hotwire 6341/6342 SDSL Router](#) on page 7 to install cables.

### Optional Cable and Adapters

Hotwire 6341/6342 SDSL Routers are typically configured remotely by the service provider. The following optional cable and adapters are only used when configuring the router locally:

- Console cable: Straight-through cable with 8-pin, non-keyed modular plugs (Part No. 035-0276-1431)
- Console adapter:
  - 8-pin modular-to-DB9 adapter plug (Part No. 002-0093-0031), or
  - A configurable DB9-to-RJ45 adapter, wired as shown on [page 16](#) of [Cables and Connectors](#).

# Installing DSL Access Wiring

The local loop terminates at the punchdown block or NID (Network Interface Device). Cables must be connected from the customer premises side of the punchdown block or NID to an RJ11 jack. Typically, the punchdown block is installed in commercial locations and the NID is installed in residential locations.

## ► Procedure

1. Access the punchdown block or NID.
2. Disconnect the DSL access pair from the local loop. A punchdown block is shown in the following example.

### Punchdown Block

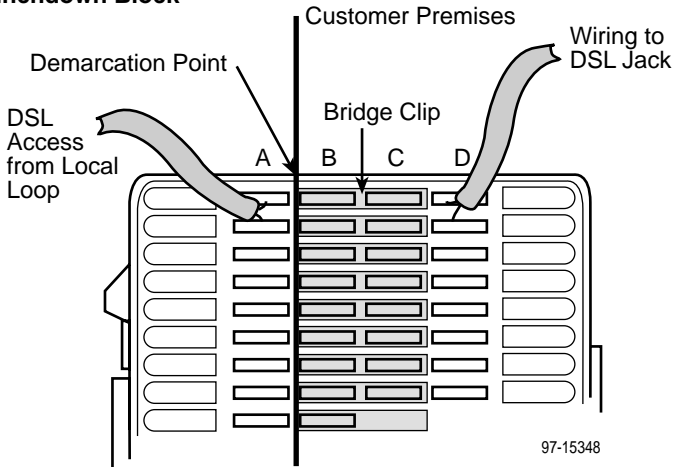

## ⚠ WARNING:

**Do not continue unless the DSL access line from the local loop has been disconnected at the NID or punchdown block. Refer to [Important Safety Instructions](#) on page 20.**

3. Locate the DSL pair of T1/R1 connectors on the customer premises side of the NID or punchdown block. Attach the cable that will be connected to the DSL jack.

---

## Connecting to the DSL Access Wiring

The Hotwire 6341 or 6342 SDSL Router connects to the local loop via wiring from the demarcation point to an RJ11 wall jack. The DSL twisted-pair wiring from the local loop terminates at a new or existing wall jack. It may be necessary to install a standard single RJ11 jack or replace a single jack with a double RJ11 jack.

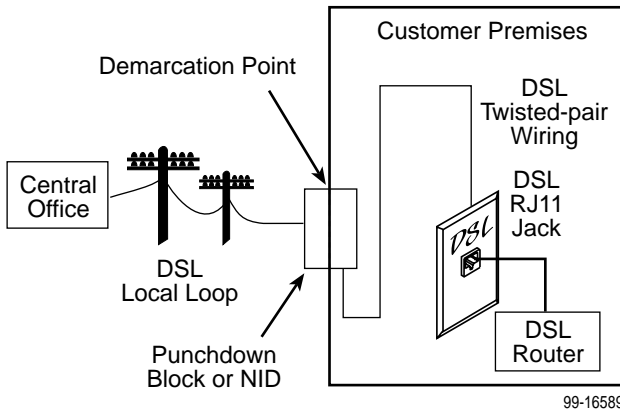

### ► Procedure

1. Wiring can be run from the punchdown block or NID to a new or existing wall jack. Match the pair colors on both ends.
2. Label the DSL jack.
3. Reconnect the DSL access pair at the punchdown block or NID. Tighten both terminal screws with a flat-blade screwdriver.

The RJ11 6-pin jack uses the two center pins. For pin assignments, refer to [Cables and Connectors](#) on page 14.

# Installing the Hotwire 6341/6342 SDSL Router

Place the SDSL Router on a flat surface, with clearance for the rear connectors.

**NOTE:**

The following illustrations show the Hotwire 6342 SDSL Router with a 4-port Ethernet hub. The Hotwire 6341 SDSL Router is identical except that it has one Ethernet port.

For router cable pin assignments, refer to *Cables and Connectors* on page 14.

## ► Procedure

1. Use the supplied RJ11 6-pin cable for the DSL connection. Insert one end of the cable into the jack labeled DSL. Insert the other end into the wall jack labeled DSL.

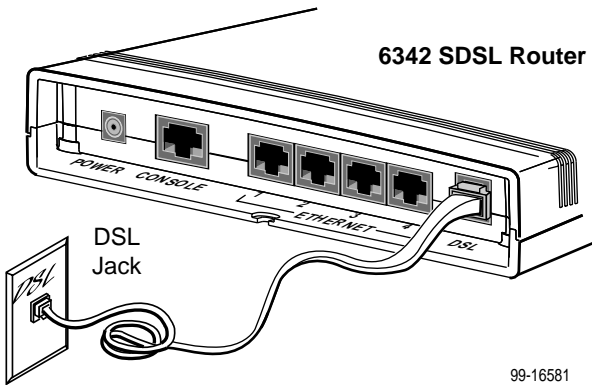

99-16581

2. Use an 8-pin Ethernet cable for the Ethernet connection. Insert one end of the cable into the jack labeled ETHERNET.

If installing a . . .	Then go to . . .
Hotwire 6341 SDSL Router	<a href="#">Step 3</a> on page 8
Hotwire 6342 SDSL Router	<a href="#">Step 4</a> on page 9

### 3. If installing the Hotwire 6341 SDSL Router:

- Use a straight-through cable to connect the other end of the cable to an Ethernet hub. Do not connect to the hub's optional Uplink connection with a straight-through cable (requires an Ethernet crossover cable).

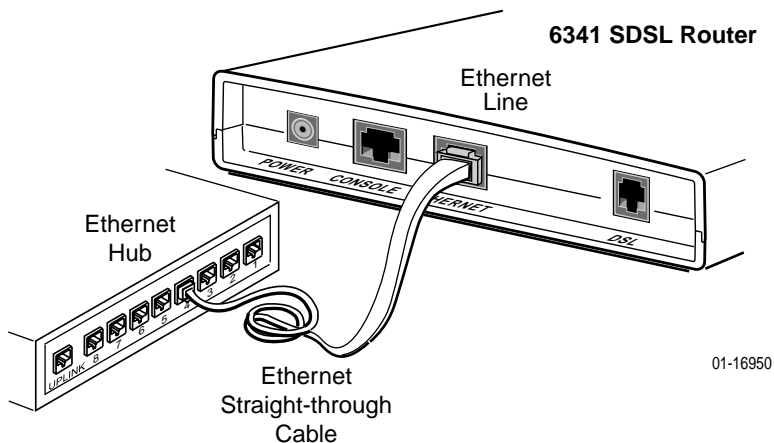

To support multiple end-user systems, refer to [Increasing the Number of End-User Systems](#) on page 14.

— or —

- Use an Ethernet crossover cable and connect the other end of the cable to a PC with an Ethernet Network Interface Card (NIC) installed.

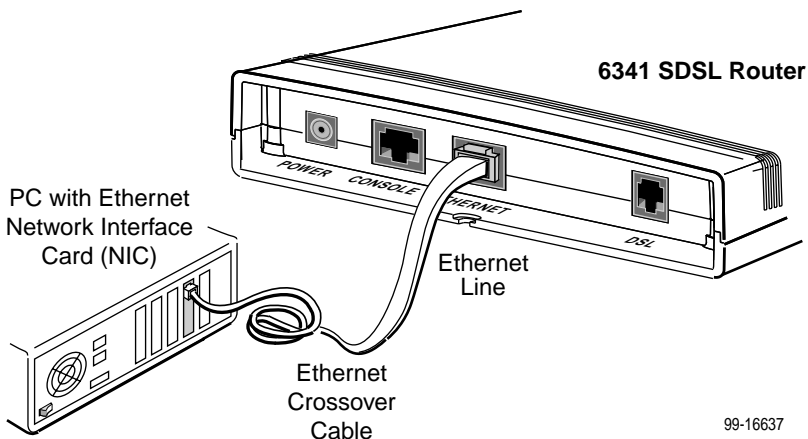

Go to [Step 5](#) on page 9.

#### 4. If installing the Hotwire 6342 SDSL Router:

- Use a straight-through cable to connect the other end of the cable to a PC with an Ethernet Network Interface Card (NIC) installed.
- **and/or** —
- Use an Ethernet crossover cable to connect the other end of the cable to an external hub.

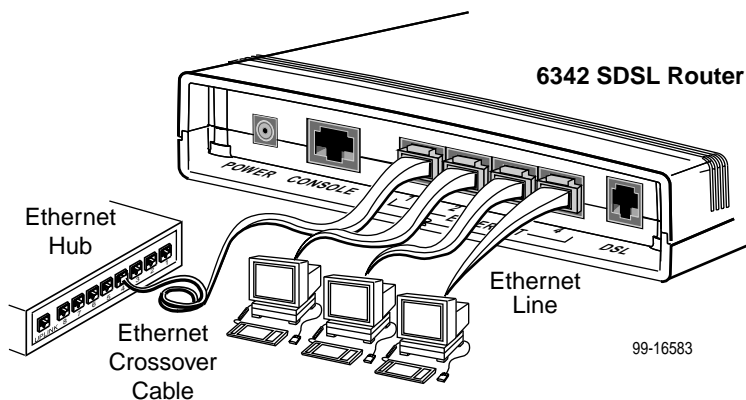

5. The Console port acts as a DCE and uses an 8-pin straight-through cable for the connection to a VT100-compatible terminal or a PC running a terminal emulation program. It is an **optional** connection that is only used for local configuration of the router. To set up the VT100 terminal or PC for local configuration and to access the router, refer to [Configuration Setup](#) and [Accessing the Router](#) on page 13.

Connect the DB9 adapter to the PC and connect the cable to a PC or laptop. Insert one end of the straight-through cable into the jack labeled CONSOLE. Insert the other end into the VT100 terminal's or PC's DB9 adapter for the serial port.

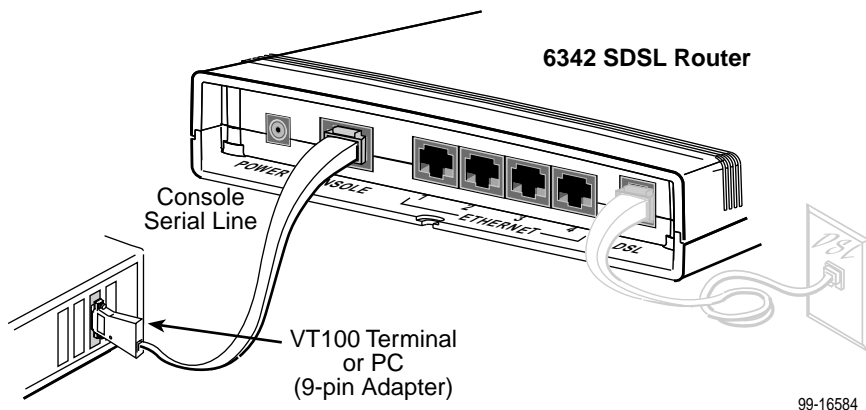

6. Insert the supplied power cord's round end into the jack labeled POWER. Plug the transformer into an AC outlet.

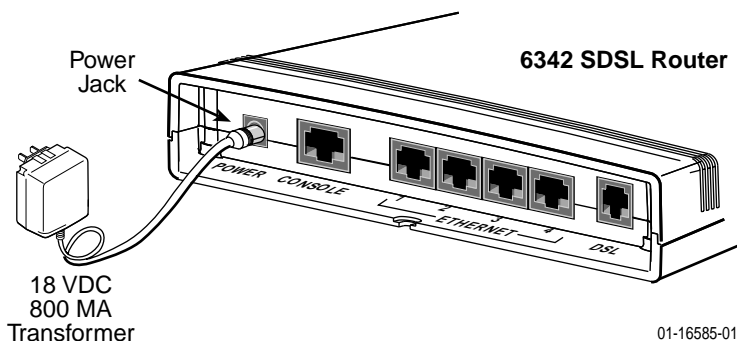

Installation of the hardware is now complete. When the power cord is installed, the router goes through a power-on self-test.

## Power-On

When power is applied, the router performs self-diagnostics and the PWR LED is on. The self-diagnostics includes a power-on self-test. During the power-on self-test, all of the LEDs turn on for one second.

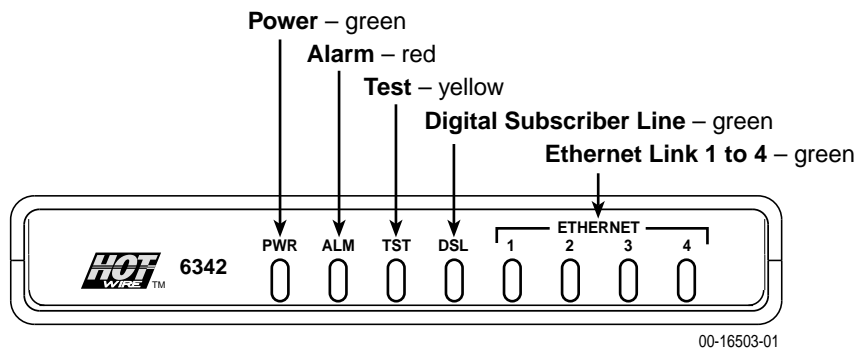

Refer to [Status LEDs](#) on page 11 for information about the LEDs. Refer to [Troubleshooting](#) on page 12 for LED indications requiring action.

---

## Status LEDs

After a successful self-test, the LEDs should appear as indicated in **BOLD** in the Condition column below.

LED	Condition	Status
PWR	<b>ON</b>	The router has power.
ALM	Blinking	A firmware download is in progress. The TST LED is also on during a download.
	<b>ON</b>	An alarm condition exists.
	<b>OFF</b>	No alarms have been detected by the router.
TST	<b>ON</b>	The TST LED is on during the power-on self-test, during a test initiated by the service provider, and during a firmware download.
	<b>OFF</b>	No tests are active.
LINE	<b>ON</b>	The DSL link is active and ready to transmit and receive data.
	<b>OFF</b>	No DSL link has been established.
TX/RX	<b>ON</b>	Data transmission is in progress on the DSL line.
	<b>OFF</b>	No data is being transmitted or received by the router.
ETHERNET LINKS 1-4	<b>ON</b>	The Ethernet connection is active.
	<b>OFF</b>	No Ethernet device is detected.

---

## Troubleshooting

LED Symptom	Action
All LEDs are on.	If the LEDs remain on for more than ten minutes, the router is not functional. Contact the service provider.
ALM LED remains on.	The power-on self-test may have failed. Unplug the router and reapply power. If the alarm LED is still on, contact the service provider.
ALM and TST LEDs are blinking.	A firmware download may be in progress. If a firmware download is not in progress, or if the LEDs continue blinking for more than ten minutes, contact the service provider.
DSL LED is off.	Verify that the DSL cable is securely installed on both ends. If the problem continues, contact the service provider.
Ethernet LED is off.	Verify that the Ethernet cable is securely installed at both ends, and at least one PC is connected and powered on.
	Verify that the correct cable is installed. For a Hotwire 6341 SDSL Router, refer to <a href="#">Step 3</a> on page 8; for a Hotwire 6342 SDSL Router, refer to <a href="#">Step 4</a> on page 9.
LINE LED is off.	Verify that the DSL LINE cable is securely installed on both ends. If the problem continues, contact the service provider.
	On lines with POTS, verify that the line has dial tone (loops without POTS do not have dial tone). If there is no dial tone on the POTS line, contact the service provider.
LINE LED is on but there is no data transmission.	The DSL link has been established but no data is being transmitted. Verify the Ethernet connection. If the problem persists, contact the service provider.
LINE and Ethernet LEDs are on and there is no data transmission.	Both the DSL and Ethernet links have been established, but no data is being transmitted. If the problem continues, contact the service provider.

LED Symptom	Action
PWR LED is off.	Check that the power cord is securely installed on both ends.
	If no LEDs are on, the power supply may be defective. Test the outlet to verify power.
	If other LEDs are on, the PWR LED may be burned out. Unplug the unit and reapply power; watch all LEDs during the power-on self-test to verify that the PWR LED is functioning. If the problem persists, contact the service provider.
TST LED is on.	A test initiated by the service provider may be active. Wait ten minutes. If the TST LED does not go off, contact the service provider.

## Configuration Setup

The Console connection is optional, used to locally configure the router. Refer to [Step 5](#) on page 9 of *Installing the Hotwire 6341/6342 SDSL Router* for details.

The Console cable is connected to a VT100-compatible terminal or a PC running a terminal emulation program. Verify the terminal settings:

- Data rate is set to 19.2 kbps (19200 bps).
- Character length is set to 8.
- Parity is set to None.
- Stop bits is set to 1.
- Flow control is set to Off or None.

## Accessing the Router

When the local console connection is first established, access control to the SDSL router displays an initial prompt of `login>`.

### ► Procedure

1. At the initial prompt of `login>`, enter the factory default Login ID of `paradyne`.
2. At the `password>` prompt, enter the factory default Password of `abc123`.
3. At the next prompt for System ID, the factory default is `CUSTOMER>`.

Type `show system` to display hardware/firmware information and Selftest Results (optional).

Refer to the *Hotwire DSL Routers User's Guide* for configuration settings and command line entries.

## Increasing the Number of End-User Systems

The router can support differing numbers of end-user systems depending on the functions that are enabled and traffic loading. Typical configurations provide support for up to 32, 64, or 256 hosts (end-user systems).

The number of end-user systems can be increased by using subnets for static addressing, or by using Dynamic Host Configuration Protocol (DHCP) for dynamic addressing.

Increasing the number of PCs may require cable changes. Refer to [Cables and Connectors](#). Refer to the *Hotwire DSL Routers User's Guide* for configuration settings and command line entries.

## Cables and Connectors

Refer to [Installing the Hotwire 6341/6342 SDSL Router](#) on page 7 for cable installation information.

Use a CAT3, or better, cable for the DSL line.

- The DSL interface uses a 6-pin, non-keyed modular plug.

### RJ11 6-Pin Connector

Pin #	Function
1 & 2	Not used
3	DSL Ring
4	DSL Tip
5 & 6	Not used

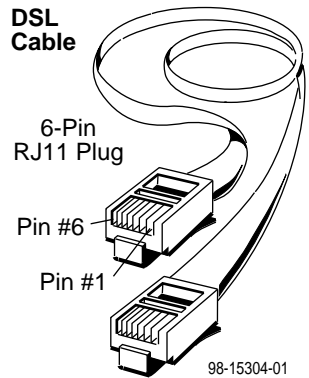

- The Ethernet interface connector uses an 8-pin, non-keyed modular plug. Use shielded twisted-pair CAT5, or better, cables.
  - To connect a Hotwire 6341 IDSL Router to an Ethernet hub, or a Hotwire 6302 IDSL Router to a PC with an Ethernet NIC card, use a straight-through connection.

### 8-Pin Straight-Through Connections

Pin #	Function
1	10/100BaseT TX D+
2	10/100BaseT TX D-
3	10/100BaseT RX D+
4 & 5	Not used
6	10/100BaseT RX D-
7 & 8	Not used

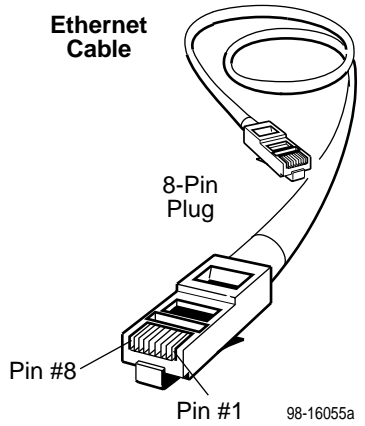

— or —

- To connect a Hotwire 6341 IDSL Router to a PC with an Ethernet NIC card, or a Hotwire 6342 IDSL Router to an external hub, use an Ethernet crossover cable.

### 8-Pin Ethernet Crossover Cable

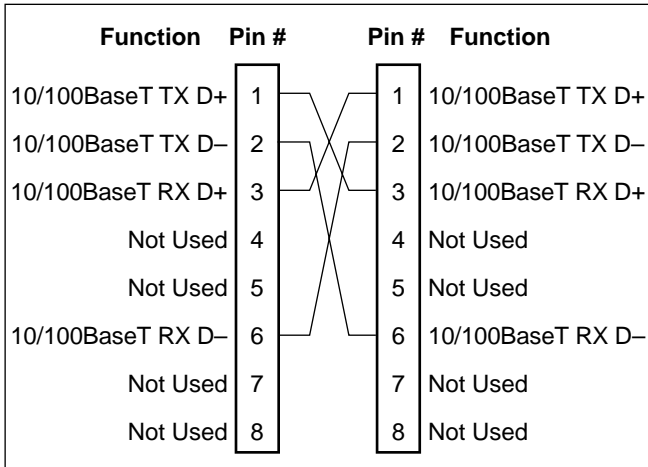

Pin #1/2 = Orange/White Twisted Pair

Pin #3/6 = Blue/White Twisted Pair

99-16518

- The Console connector uses 8-pin, non-keyed modular plugs and a DB9 adapter. See [Step 5](#) on page 9.

### RJ45 8-Pin Connector

Pin #	Circuit	Direction
1	Not used	—
2	DTR	Input to Console port
3	TXD	Input
4 & 5	Signal Ground	—
6	RXD	Output
7	DSR	Output
8	Not used	—

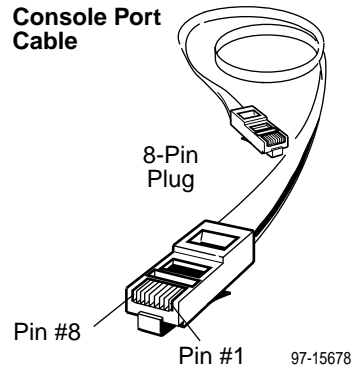

### 8-Pin Modular to DB9 Adapter Plug

Modular Pin #	Circuit	DB9 Pin #
1	RTS	7
2	DTR	4
3	TXD	3
4 & 5	Signal Ground	5
6	RXD	2
7	DSR	6
8	CTS	8

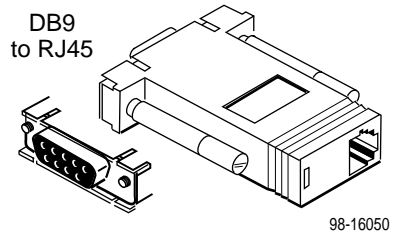

---

## Optional Wall Placement

The Hotwire 6341 and 6342 SDSL routers are designed for tabletop placement. The SDSL router can also be mounted on a wall.

To mount the SDSL router, you will need:

- Three #6 pan-head screws with anchors (e.g., molly bolts, plastic or lead anchors)
- Drill, and the correct size drill bit for the anchors
- Screwdriver

A template with the dimensions for the three screws is provided. See [SDSL Router Hardware Template](#) on page 18.

### ► Procedure

To mount the SDSL router:

1. Drill the correct size hole for the anchors and install them. Use the template to gauge their placement.
2. Screw the pan-head screws into the installed anchors. Do not make them flush with the wall. Leave enough clearance to hang the router housing from the screws.

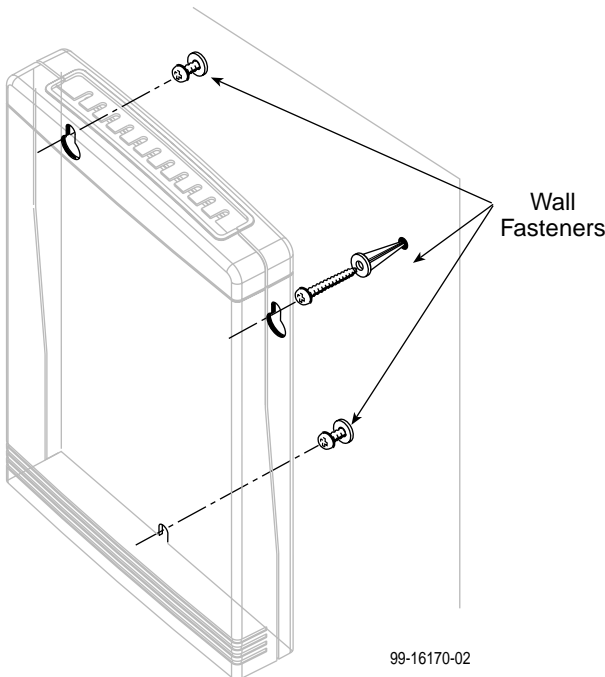

99-16170-02

Refer to [Installing the Hotwire 6341/6342 SDSL Router](#) on page 7 to install the cables.

# SDSL Router Hardware Template

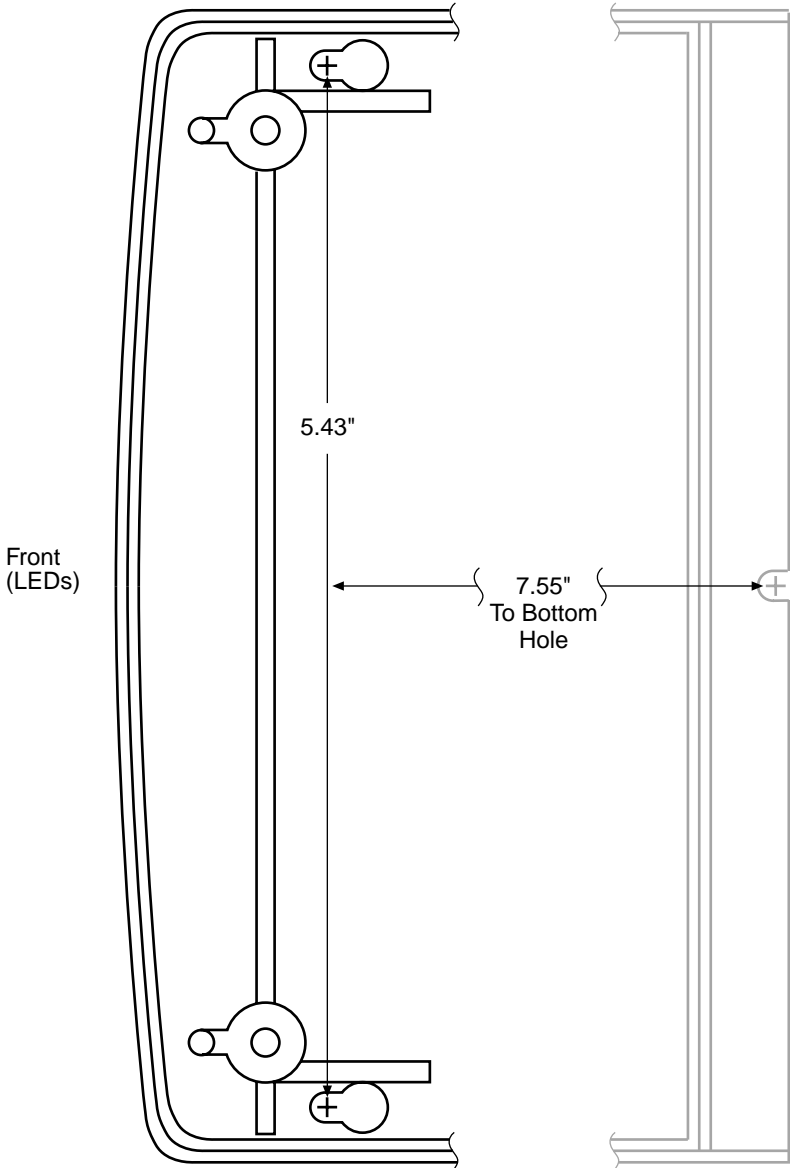

# SDSL Router Technical Specifications

Item	Specification*
<b>Height x Width x Depth</b>	1.43" x 6.00" x 8.75" (3.64 cm x 15.24 cm x 22.23 cm)
<b>Weight</b>	1 lb. 1 oz. (0.48 kg)
<b>External Power Supply</b> Class 2 Transformer normal service input voltage range	Input: 100 VAC ( $\pm 10\%$ ), 50 Hz; 120 VAC ( $\pm 10\%$ ), 60 Hz; or 230 VAC ( $\pm 10\%$ ), 50/60 Hz  Output: 18 VDC nominal at 0.8A
<b>Unit Power Consumption</b>	<ul style="list-style-type: none"> <li>■ Hotwire SDSL 6341: 5 watts (nominal)</li> <li>■ Hotwire SDSL 6342: 8 watts (nominal)</li> </ul>
<b>Approvals</b>  FCC Part 15 CISPR 22 Safety Certifications	Class B Subpart B digital device Class B Refer to equipment's label for approvals on product.
<b>Physical Environment</b>  Operating temperature Storage temperature Relative humidity Shock and vibration	32°F to 104°F (0°C to 40°C) -4°F to 158°F (-20°C to 70°C) 5% to 95% (noncondensing) Withstands normal shipping and handling
<b>Interface Connectors</b>  DSL Interface Console Interface Ethernet Type II Frame	RJ11 6-pin 8-pin 10/100BaseT 8-pin <ul style="list-style-type: none"> <li>■ Hotwire SDSL 6341: One Ethernet connector</li> <li>■ Hotwire SDSL 6342: Four Ethernet connectors</li> </ul>

\* Technical Specifications are subject to change without notification.

---

## **⚠ Important Safety Instructions**

1. Read and follow all warning notices and instructions marked on the product or included in the manual.
2. Slots and openings in the cabinet are provided for ventilation. To ensure reliable operation of the product and to protect it from overheating, these slots and openings must not be blocked or covered.
3. Do not allow anything to rest on the power cord and do not locate the product where persons will walk on the power cord.
4. Do not attempt to service this product yourself, as opening or removing covers may expose you to dangerous high voltage points or other risks. Refer all servicing to qualified service personnel.
5. General purpose cables are used with this product for connection to the network. Special cables, which may be required by the regulatory inspection authority for the installation site, are the responsibility of the customer. Use a UL Listed, CSA certified, minimum No. 24 AWG line cord for connection to the Digital Subscriber Line (DSL) network.
6. When installed in the final configuration, the product must comply with the applicable Safety Standards and regulatory requirements of the country in which it is installed. If necessary, consult with the appropriate regulatory agencies and inspection authorities to ensure compliance.
7. A rare phenomenon can create a voltage potential between the earth grounds of two or more buildings. If products installed in separate buildings are **interconnected**, the voltage potential may cause a hazardous condition. Consult a qualified electrical consultant to determine whether or not this phenomenon exists and, if necessary, implement corrective action prior to interconnecting the products.
8. Input power to this product must be provided by one of the following: (1) a UL Listed/CSA certified power source with a Class 2 or Limited Power Source (LPS) output for use in North America, or (2) a certified transformer, with a Safety Extra Low Voltage (SELV) output having a maximum 240 VA available, for use in the country of installation.
9. In addition, since the equipment is to be used with telecommunications circuits, take the following precautions:
  - Never install telephone wiring during a lightning storm.
  - Never install telephone jacks in wet locations unless the jack is specifically designed for wet locations.
  - Never touch uninsulated telephone wires or terminals unless the telephone line has been disconnected at the network interface.
  - Use caution when installing or modifying telephone lines.
  - Avoid using a telephone (other than a cordless type) during an electrical storm. There may be a remote risk of electric shock from lightning.
  - Do not use the telephone to report a gas leak in the vicinity of the leak.

---

**⚠ CANADA – EMI NOTICE:**

**This Class B digital apparatus meets all requirements of the Canadian interference-causing equipment regulations.**

**Cet appareil numérique de la classe B respecte toutes les exigences du règlement sur le matériel brouilleur du Canada.**

## **Government Requirements**

Certain governments require that instructions pertaining to connection to the telephone network be included in the installation and operation manual. Specific instructions are listed in the following sections.

### **Notice to Users of the Canadian Telephone Network**

The Industry Canada label identifies certified equipment. This certification means that the equipment meets telecommunications network protective, operational and safety requirements as prescribed in the appropriate Terminal Equipment Technical Requirements document(s). The Department does not guarantee the equipment will operate to the user's satisfaction.

Before installing this equipment, users should ensure that it is permissible to be connected to the facilities of the local telecommunications company. The equipment must also be installed using an acceptable method of connection. The customer should be aware that compliance with the above conditions may not prevent degradation of service in some situations.

Repairs to certified equipment should be coordinated by a representative designated by the supplier. Any repairs or alterations made by the user to this equipment, or equipment malfunctions, may give the telecommunications company cause to request to disconnect the equipment.

Users should ensure for their own protection that the electrical ground connections of the power utility, telephone lines and internal metallic water pipe system, if present, are connected together. This precaution may be particularly important in rural areas.

#### **CAUTION:**

**Users should not attempt to make such connections themselves, but should contact the appropriate electric inspection authority, or electrician, as appropriate.**

The Ringer Equivalence Number (REN) assigned to each terminal device provides an indication of the maximum number of terminals allowed to be connected to a telephone interface. The termination on an interface may consist of any combination of devices subject only to the requirement that the sum of the Ringer Equivalence Numbers of all the devices does not exceed 5.

If your equipment is in need of repair, refer to [Warranty, Sales, Service, and Training Information](#) on page 24.

---

## Declaration of Conformity

This Declaration of Conformity is made by Paradyne Corporation pursuant to Parts 2 and 15 of the Federal Communications Commission's Rules. This compliance information statement pertains to the following products:

Trade Name: Hotwire

Model Number: 6341-A1-200 and 6342-A1-200

This device complies with Part 15 of the FCC Rules. Operation is subject to the following two conditions: (1) this device may not cause harmful interference, and (2) this device must accept any interference received, including interference that may cause undesired operation.

The name, address, and telephone number of the responsible party is given below:

Paradyne Corporation  
8545 126th Avenue North  
Largo, FL 33773-1502  
Phone: (727) 530-2000

The authority to operate this equipment is conditioned by the requirement that no modifications will be made to the equipment unless the changes or modifications are expressly approved by Paradyne Corporation.

This equipment has been tested and found to comply with the limits for a Class B digital device, pursuant to Part 15 of the FCC Rules. These limits are designed to provide reasonable protection against harmful interference in a residential installation. This equipment generates, uses, and can radiate radio frequency energy and, if not installed and used in accordance with the instructions, may cause harmful interference to radio communications. However, there is no guarantee that interference will not occur in a particular installation. If this equipment does cause harmful interference to radio or television reception, which can be determined by turning the equipment off and on, the user is encouraged to try to correct the interference by one or more of the following measures:

- Reorient or relocate the receiving antenna.
- Increase the separation between the equipment and receiver.
- Connect the equipment into an outlet on a circuit different from that to which the receiver is connected.
- Consult the dealer or an experienced radio/TV technician for help.

---

## Japan Notices

この装置は、情報処理装置等電波障害自主規制協議会（VCCI）の基準に基づくクラスB情報技術装置です。この装置は、家庭環境で使用することを目的としていますが、この装置がラジオやテレビジョン受信機に近接して使用されると、受信障害を引き起こすことがあります。

取扱説明書に従って正しい取り扱いをして下さい。

This is a Class B product based on the standard of the Voluntary Control Council for Interference from Information Technology Equipment (VCCI). If this is used near a radio or television receiver in a domestic environment, it may cause radio interference. Install and use the equipment according to the instruction manual.

## CE Marking

When the product is marked with the CE mark on the equipment label, this demonstrates full compliance with the following European Directives:

- **Directive 73/23/EEC** – Council Directive of 19 February 1973 on the harmonization of the laws of the member states relating to electrical equipment designed for use within states relating to electrical equipment designed for use within certain voltage limits, as amended by Directive 93/68/EEC.
- **Directive 89/336/EEC** – Council Directive of 3 May 1989 on the approximation of the laws of the member states relating to Electro-Magnetic Compatibility (EMC), as amended by Directive 93/68/EEC.

---

## Warranty, Sales, Service, and Training Information

Contact your local sales representative, service representative, or distributor directly for any help needed. For additional information concerning warranty, sales, service, repair, installation, documentation, training, distributor locations, or Paradyne worldwide office locations, use one of the following methods:

- **Internet:** Visit the Paradyne World Wide Web site at **www.paradyne.com**. (Be sure to register your warranty at **www.paradyne.com/warranty**.)
- **Telephone:** Call our automated system to receive current information by fax or to speak with a company representative.
  - Within the U.S.A., call 1-800-870-2221
  - Outside the U.S.A., call 1-727-530-2340

## Document Feedback

We welcome your comments and suggestions about this document. Please mail them to Technical Publications, Paradyne Corporation, 8545 126th Ave. N., Largo, FL 33773, or send e-mail to **userdoc@paradyne.com**. Include the number and title of this document in your correspondence. Please include your name and phone number if you are willing to provide additional clarification.

## Trademarks

Hotwire and MVL are registered trademarks of Paradyne Corporation. All other products and services mentioned herein are the trademarks, service marks, registered trademarks, or registered service marks of their respective owners.



\*6341-A2-GN10-20\*