

Hotwire® 6350 ReachDSL™ Modem With Inline Phone Filter Installation Instructions

Document Number 6350-A2-GN10-10

December 2000

Contents

Hotwire 6350 ReachDSL Modem Overview	1
Installing the Hotwire 6350 ReachDSL Modem	5
Power-On	7
Troubleshooting	8
Cables & Connectors	10
Important Safety Instructions	15

Hotwire 6350 ReachDSL Modem Overview

The Hotwire® 6350 ReachDSL™ Modem is a component in the Hotwire ReachDSL System and interoperates with the Hotwire 8312 or 8314 ReachDSL/MVL® Card in the Hotwire DSLAM (Digital Subscriber Line Access Multiplexer) system. This system provides high-speed Internet or corporate LAN access over traditional twisted-pair copper telephone wiring.

The ReachDSL technology:

- Operates over existing copper wire with existing telephone jacks.
- Utilizes an inline phone filter on the modem's PHONE jack.
- Includes a second line pass-through from the ReachDSL modem's LINE jack to PHONE jack to accommodate an attached 2-line telephone.
- Provides adaptive data rates to dynamically adapt and allocate bandwidth to optimize applications.

Hotwire ReachDSL System

Copper pairs run from the central office (CO) to the customer premises (CP) to create the local loop. The local loop terminates on the customer premises at the demarcation point.

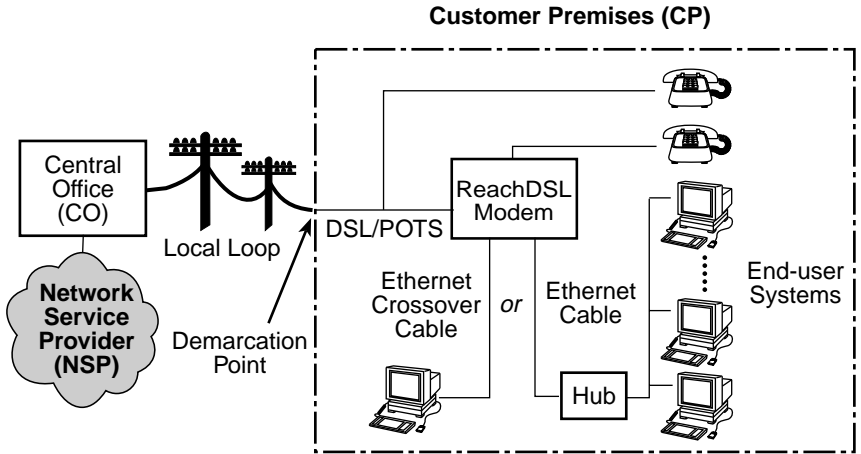

DSL – Digital Subscriber Lines
POTS – Plain Old Telephone Service

NOTES:

In this document:

- A telephone is used to represent any equipment that plugs into a phone jack and uses the POTS line, such as a phone, modem, or fax machine.
- End-user system is used to represent any PC with an Ethernet connection and ReachDSL-based service.
- RJ11 wall jack is used to represent either an RJ11 or an RJ14 wall jack. The RJ14 wall jack is used for a phone with two lines.
- Service provider is used to represent any Internet Service Provider (ISP) or remote LAN access provider.

Phone Filter

The Hotwire 6350 ReachDSL Modem includes an internal phone filter. If additional telephones are used on the same phone line as the ReachDSL modem, install one phone filter on each telephone that is not directly attached to the modem.

There are two Hotwire ReachDSL phone filters:

- Hotwire 6035 MVL Phone Filter is designed for use with a tabletop phone.
- Hotwire 6040 MVL Wall Jack Phone Filter is designed for use with a wall phone.

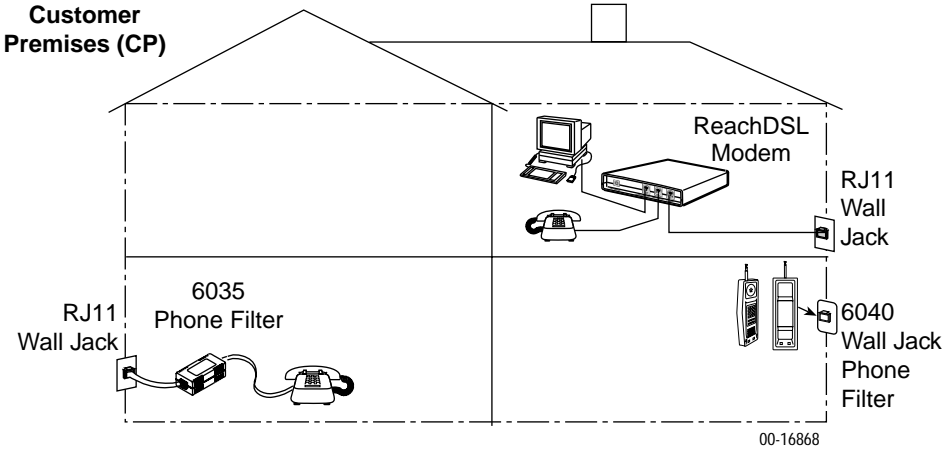

Product-Related Documents

To install a phone filter, refer to the appropriate document:

Document Number	Document Title
6035-A2-GN11	<i>Hotwire 6035 MVL Phone Filter Installation Instructions</i>
6040-A2-GN11	<i>Hotwire 6040 MVL Wall Jack Phone Filter Installation Instructions</i>

Contact your sales or service representative to order additional product documentation.

Paradyne documents are available on the World Wide Web at www.paradyne.com.
Select *Library* → *Technical Manuals* → *Hotwire DSL & MVL Systems*.

Before You Begin

Verify that your package contains the following:

- Hotwire 6350 ReachDSL Modem
- DSL interface cable with RJ11 connectors
- Power cord with power transformer

Be sure to register your warranty at www.paradyne.com/warranty.

Wiring and Cables You Need

The following standard cables and connectors are used with this product:

- Standard RJ11 (or RJ14) wall jack for the DSL cabling.
- Standard Ethernet 8-pin, non-keyed modular plug for a PC or workstation with an Ethernet straight-through or crossover cable.

Refer to *Installing the Hotwire 6350 ReachDSL Modem* on page 5 for Ethernet cable installation details.

Refer to *Cables & Connectors* on page 10 for DSL and Ethernet cable pin assignments.

Installing the Hotwire 6350 ReachDSL Modem

Place the Hotwire 6350 ReachDSL Modem on a flat surface with clearance for the rear connectors.

► Procedure

1. If a telephone is connected at the RJ11 wall jack where the modem will be installed, unplug the telephone line from the wall jack.
2. Use the supplied RJ11 6-pin interface cable for the ReachDSL LINE connection. Insert one end of the cable into the jack labeled LINE. Insert the other end of the cable into the RJ11 wall jack.

ReachDSL Modem

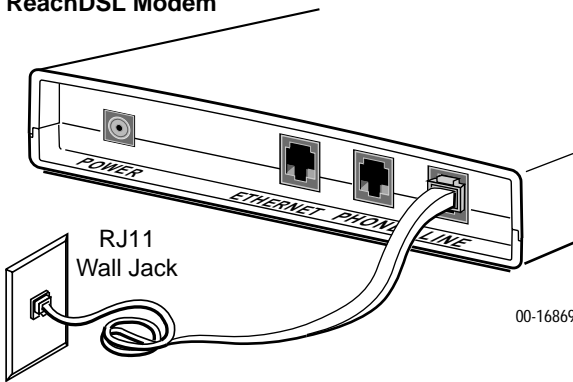

3. Connect a telephone (optional – go to Step 4 if you are not connecting a telephone to the ReachDSL modem).
Plug the existing telephone interface cable that was unplugged in Step 1 into the jack labeled PHONE.

-
4. Use an 8-pin Ethernet cable for the Ethernet connection. Insert one end of the cable into the jack labeled ETHERNET.
- Use a straight-through cable and connect the other end to an Ethernet hub. (To connect to a hub's Uplink connection, use an Ethernet crossover cable).

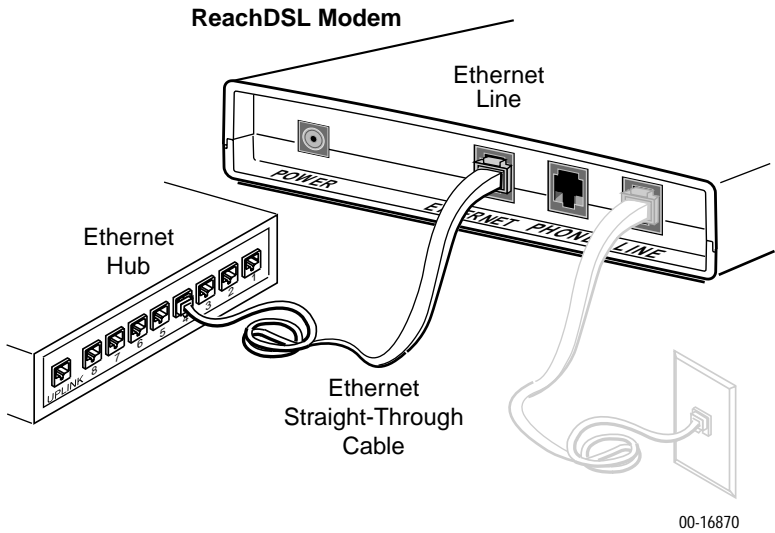

—or—

- Use an Ethernet crossover cable and connect the other end to a PC with an Ethernet Network Interface Card (NIC) installed.

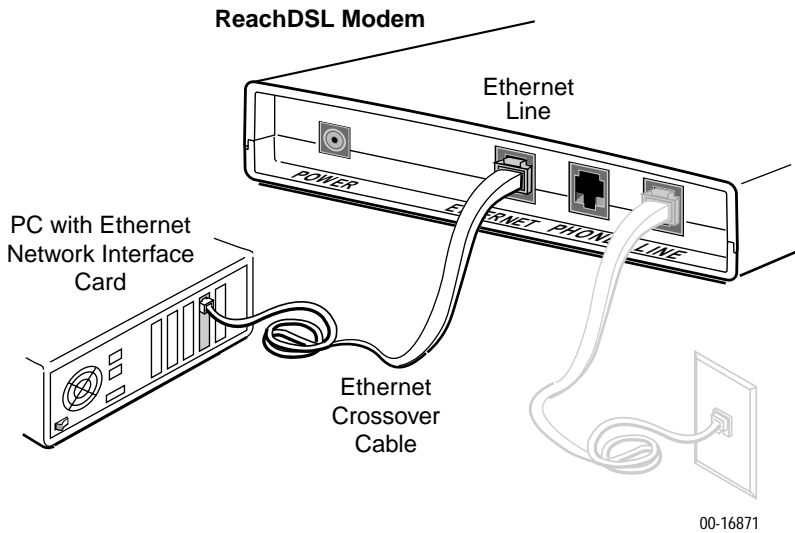

5. Insert the supplied power cord's round end into the jack labeled POWER. Plug the transformer into an AC outlet.

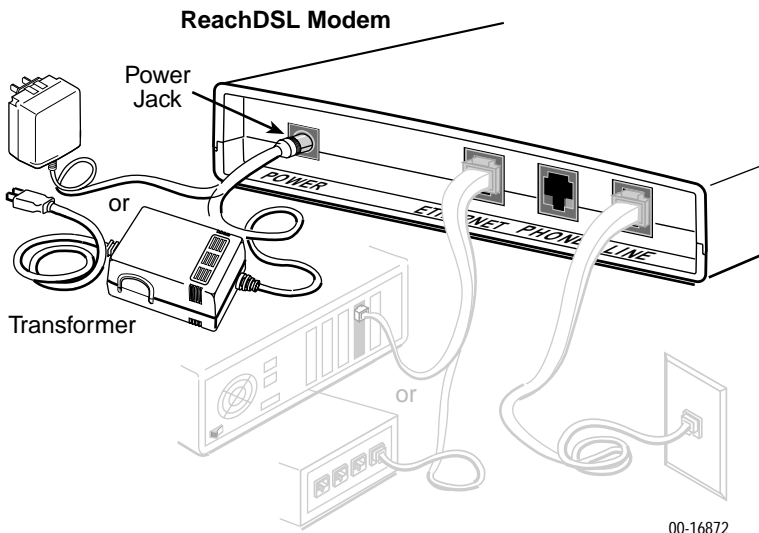

The ReachDSL modem hardware installation is now complete. When the power cord is installed, the ReachDSL modem goes through a power-on self-test.

Power-On

When power is applied, the ReachDSL modem performs self-diagnostics and the PWR LED is on. The self-diagnostics includes a power-on self-test and all of the LEDs turn on for one second.

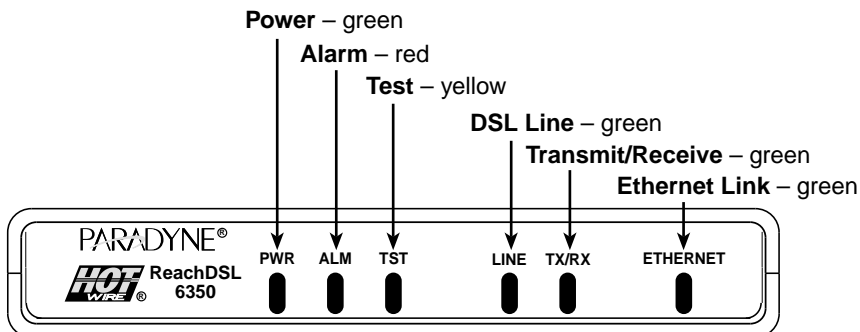

00-16873

Refer to *Troubleshooting* on page 8 for LED indications requiring action.

Status LEDs

All of the LEDs turn on and off during the power-on self-test. After a successful self-test, the LEDs should appear as indicated in **BOLD** in the Condition column below.

LED	Condition	Status
PWR	ON	ReachDSL modem has power.
ALM	OFF ON	No active alarms. An alarm condition exists.
TST	OFF ON	No active tests. The TST LED is on during the power-on self-test and during a test initiated by the service provider.
LINE	ON OFF	The DSL link is active and ready to transmit and receive data. The DSL link has not been established.
TX/RX	ON OFF	Data transmission is in progress on the DSL line. The modem is not transmitting or receiving data.
ETHERNET	ON OFF	The Ethernet connection to the Ethernet hub or PC is active. No Ethernet 10BaseT device is detected.

Troubleshooting

LED Symptom	Action
All LEDs are on.	If LEDs remain on after ten minutes, the modem is not functional. Contact the service provider.
ALM LED remains on.	The power-on self-test may have failed. Unplug the unit and reapply power. If the alarm LED is still on, contact the service provider.
ALM and TST LEDs are blinking.	Firmware download may be in progress. If firmware download is not in progress or the LEDs continue blinking after ten minutes, contact the service provider.
Ethernet LED is off.	Verify that the Ethernet cable is securely installed at both ends, and at least one PC is connected and powered on. Verify that the correct straight-through or crossover cable is installed. Refer to <i>Installing the Hotwire 6350 ReachDSL Modem</i> on page 5.

LED Symptom	Action
LINE LED is off.	Verify that the DSL LINE cable is securely installed on both ends. If the problem continues, contact the service provider.
	Verify that the line has dial tone. If there is no dial tone, contact the service provider.
LINE LED is on and there is no data transmission.	The DSL link has been established but there is no data transmission. Verify the Ethernet connection. If the problem persists, contact the service provider.
LINE and Ethernet LEDs are on and there is no data transmission.	The DSL and Ethernet links have been established but there is no data transmission. If the problem continues, contact the service provider.
PWR LED is off.	Check that the power cord is securely installed on both ends.
	If no LEDs are on, the power supply may be defective. Test the outlet to verify power. If the problem persists, contact the service provider.
	If other LEDs are on, the PWR LED may be burned out. Unplug the unit and reapply power; watch all LEDs during the power-on self-test to verify if the PWR LED is functioning.
TST LED is on.	A test initiated by the service provider may be active. Wait five minutes. If the TST LED does not go off, contact the service provider.

To improve data transmission throughput and minimize background noise during a telephone conversation, make sure that:

- The Hotwire 6350 ReachDSL Modem is always powered on, even when not in use, and
- A Hotwire MVL phone filter is installed on every telephone on the same line as the Hotwire 6350 ReachDSL Modem.

Increasing the Number of End-User Systems

A single end-user system is attached to the Hotwire 6350 ReachDSL Modem by using an Ethernet crossover cable. To increase the number of end-user systems, connect all the PCs to an Ethernet hub using a straight-through cable.

The Hotwire ReachDSL/MVL port card supports 32 hosts/subnets per DSL port and the Hotwire ReachDSL Modem supports up to 256 MAC entries.

Cables & Connectors

This section is reference information.

Standard twisted-pair CAT3 or better cables are recommended.

- The LINE and PHONE interface connectors use 6-pin, non-keyed modular plugs. RJ11 or RJ14 6-pin connectors can be used.

Line & Phone Connectors

Pin #	Function
1	Not used
2	Ring 2 (optional)
3	DSL Ring 1
4	DSL Tip 1
5	Tip 2 (optional)
6	Not used

6-Pin RJ11 Plugs

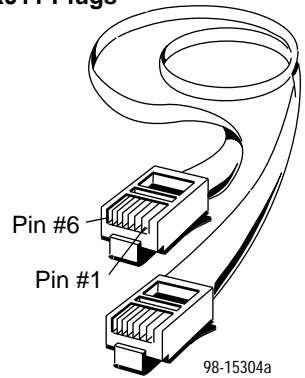

- The LINE and PHONE jack pinouts are either filtered or unfiltered for POTS.

PHONE Jack Pinouts		LINE Jack Pinouts	
Pin # 3, 4	Filtered for POTS	Pin # 3, 4	DSL and POTS
Pin # 2, 5	2nd POTS unfiltered	Pin # 2, 5	2nd line pass-through

- The Ethernet interface connector uses an 8-pin, non-keyed modular plug.
 - To connect the DSL modem to an Ethernet hub, use the straight-through connection.

8-Pin Straight-Through Connection

Pin #	Function
1	10BaseT TX D+
2	10BaseT TX D-
3	10BaseT RX D+
4 & 5	Not used
6	10BaseT RX D-
7 & 8	Not used

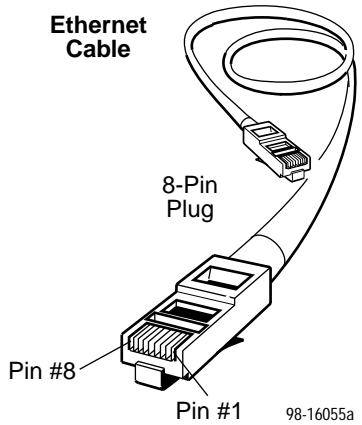

-or-

- To connect the DSL modem directly to a PC with an Ethernet NIC card, use an Ethernet crossover cable.

8-Pin Ethernet Crossover Cable

Function	Pin #	Pin #	Function
10/100BaseT TX D+	1	3	10/100BaseT TX D+
10/100BaseT TX D-	2	6	10/100BaseT TX D-
10/100BaseT RX D+	3	1	10/100BaseT RX D+
Not Used	4	4	Not Used
Not Used	5	5	Not Used
10/100BaseT RX D-	6	2	10/100BaseT RX D-
Not Used	7	7	Not Used
Not Used	8	8	Not Used

Pin #1/2 = Orange/White Twisted Pair

Pin #3/6 = Blue/White Twisted Pair

99-16518

Optional Modem Wall Placement

The Hotwire 6350 ReachDSL Modem is designed for tabletop placement. The DSL modem can also be mounted on a wall. To mount the modem, you will need:

- Three slotted-head #6 self-threading screws with molly bolts
- Drill and 3/16" drill bit for the molly bolts
- Screwdriver

A template with the dimensions for the three screws is provided. See *Modem Hardware Template* on page 13.

► Procedure

To mount the Hotwire 6350 ReachDSL Modem:

1. Use a drill to install the plastic anchors (molly bolts).
2. Use a screwdriver to install the screws. Do not install the screws flush with the wall. Leave enough clearance to hang the modem housing from the screws.

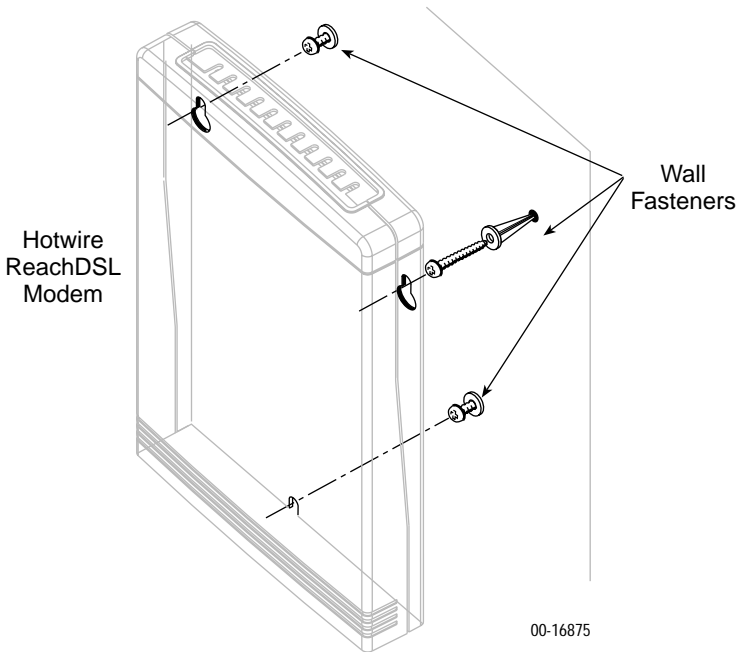

Modem Hardware Template

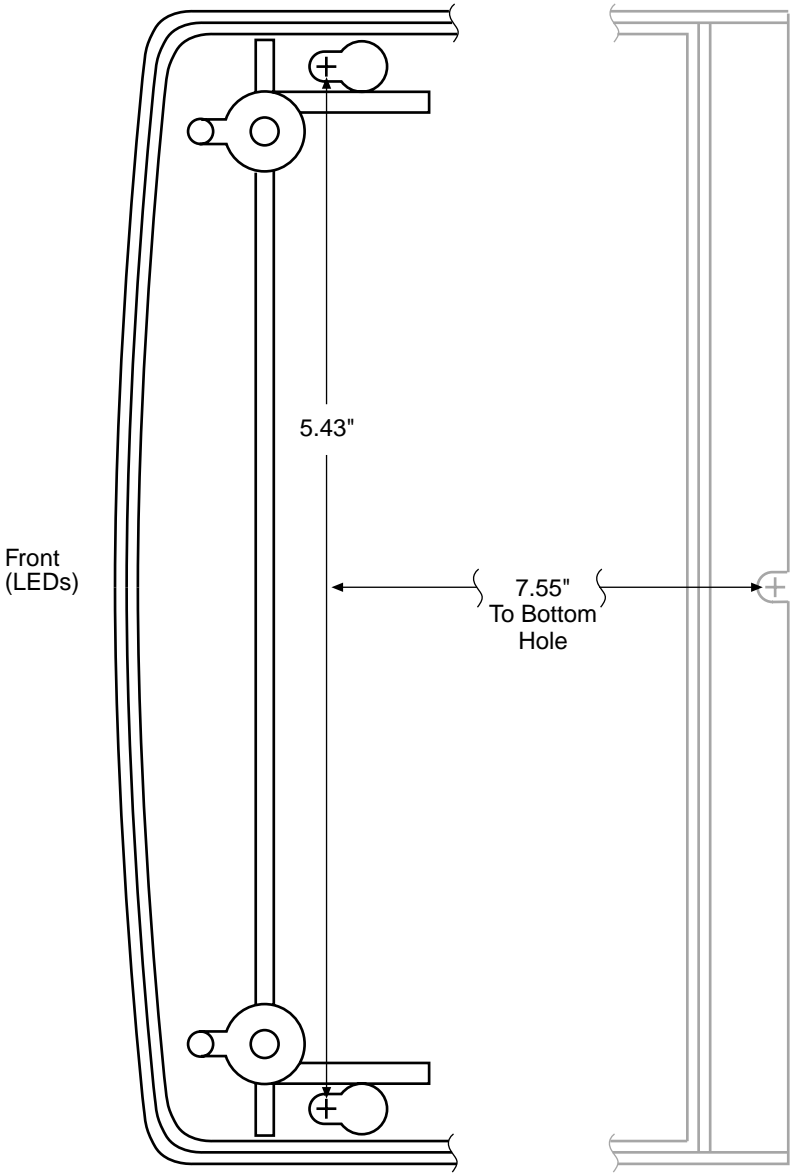

Technical Specifications for 6350 ReachDSL Modem

Item	Specification*
Height x Width x Depth	1.25" x 6.00" x 8.75" (3.18 cm x 15.24 cm x 22.23 cm)
Weight	1 lb. 1 oz. (0.48 kg)
Power Class 2 Transformer normal service input voltage range	Input: 100 VAC ($\pm 10\%$), 50 Hz; 120 VAC ($\pm 10\%$), 60 Hz; or 230 VAC ($\pm 10\%$), 50/60 Hz Output: 15 VDC nominal, minimum 0.6A (SELV)
Approvals FCC Part 15 CISPR 22 Safety Certifications	Class B digital device Class B Refer to equipment's label for approvals on product
Physical Environment Operating temperature Storage temperature Relative humidity Shock and vibration	32°F to 104°F (0°C to 40°C) -4°F to 158°F (-20°C to 70°C) 5% to 95% (noncondensing) Withstands normal shipping and handling
Heat Dissipation	22.2 Btu/hr. (max.) at nominal input voltage
Interface Connectors Line Interface Ethernet Type II Frame	RJ11 or RJ14 6-pin 10BaseT 8-pin
* Technical Specifications subject to change without notification.	

⚠ Important Safety Instructions

1. Read and follow all warning notices and instructions marked on the product or included in the manual.
2. Slots and openings in the cabinet are provided for ventilation. To ensure reliable operation of the product and to protect it from overheating, these slots and openings must not be blocked or covered.
3. Do not allow anything to rest on the power cord and do not locate the product where persons will walk on the power cord.
4. Do not attempt to service this product yourself, as opening or removing covers may expose you to dangerous high voltage points or other risks. Refer all servicing to qualified service personnel.
5. General purpose cables are used with this product for connection to the network. Special cables, which may be required by the regulatory inspection authority for the installation site, are the responsibility of the customer. Use a UL Listed, CSA certified, minimum No. 24 AWG line cord for connection to the Digital Subscriber Line (DSL) network.
6. When installed in the final configuration, the product must comply with the applicable Safety Standards and regulatory requirements of the country in which it is installed. If necessary, consult with the appropriate regulatory agencies and inspection authorities to ensure compliance.
7. A rare phenomenon can create a voltage potential between the earth grounds of two or more buildings. If products installed in separate buildings are **interconnected**, the voltage potential may cause a hazardous condition. Consult a qualified electrical consultant to determine whether or not this phenomenon exists and, if necessary, implement corrective action prior to interconnecting the products.
8. Input power to this product must be provided by one of the following: (1) a UL Listed/CSA certified power source with a Class 2 or Limited Power Source (LPS) output for use in North America, or (2) a certified transformer, with a Safety Extra Low Voltage (SELV) output having a maximum of 240 VA available, for use in the country of installation.
9. In addition, since the equipment is to be used with telecommunications circuits, take the following precautions:
 - Never install telephone wiring during a lightning storm.
 - Never install telephone jacks in wet locations unless the jack is specifically designed for wet locations.
 - Never touch uninsulated telephone wires or terminals unless the telephone line has been disconnected at the network interface.
 - Use caution when installing or modifying telephone lines.
 - Avoid using a telephone (other than a cordless type) during an electrical storm. There may be a remote risk of electric shock from lightning.
 - Do not use the telephone to report a gas leak in the vicinity of the leak.

CE Marking

When the product is marked with the CE mark on the equipment label, this demonstrates full compliance with the following European Directives:

- **Directive 73/23/EEC** – Council Directive of 19 February 1973 on the harmonization of the laws of the member states relating to electrical equipment designed for use within states relating to electrical equipment designed for use within certain voltage limits, as amended by Directive 93/68/EEC.
- **Directive 89/336/EEC** – Council Directive of 3 May 1989 on the approximation of the laws of the member states relating to Electro-Magnetic Compatibility (EMC), as amended by Directive 93/68/EEC.

CANADA – EMI NOTICE:

This Class B digital apparatus meets all requirements of the Canadian interference-causing equipment regulations.

Cet appareil numérique de la classe B respecte toutes les exigences du règlement sur le matériel brouilleur du Canada.

Japan

Notices

この装置は、情報処理装置等電波障害自主規制協議会（VCCI）の基準に基づくクラスB情報技術装置です。この装置は、家庭環境で使用することを目的としていますが、この装置がラジオやテレビジョン受信機に近接して使用されると、受信障害を引き起こすことがあります。

取扱説明書に従って正しい取り扱いをして下さい。

This is a Class B product based on the standard of the Voluntary Control Council for Interference from Information Technology Equipment (VCCI). If this is used near a radio or television receiver in a domestic environment, it may cause radio interference. Install and use the equipment according to the instruction manual.

Declaration of Conformity

This Declaration of Conformity is made by Paradyne Corporation pursuant to Parts 2 and 15 of the Federal Communications Commission's Rules. This compliance information statement pertains to the following products:

Trade Name: Hotwire
Model Number: 6350-A3-200

This device complies with Part 15 of the FCC Rules. Operation is subject to the following two conditions: (1) this device may not cause harmful interference, and (2) this device must accept any interference received, including interference that may cause undesired operation.

The name, address, and telephone number of the responsible party is given below:

Paradyne Corporation
8545 126th Avenue North
Largo, FL 33773-1502
Phone: (727) 530-2000

The authority to operate this equipment is conditioned by the requirement that no modifications will be made to the equipment unless the changes or modifications are expressly approved by Paradyne Corporation.

This equipment has been tested and found to comply with the limits for a Class B digital device, pursuant to Part 15 of the FCC Rules. These limits are designed to provide reasonable protection against harmful interference in a residential installation. This equipment generates, uses, and can radiate radio frequency energy and, if not installed and used in accordance with the instructions, may cause harmful interference to radio communications. However, there is no guarantee that interference will not occur in a particular installation. If this equipment does cause harmful interference to radio or television reception, which can be determined by turning the equipment off and on, the user is encouraged to try to correct the interference by one or more of the following measures:

- Reorient or relocate the receiving antenna.
- Increase the separation between the equipment and receiver.
- Connect the equipment into an outlet on a circuit different from that to which the receiver is connected.
- Consult the dealer or an experienced radio/TV technician for help.

Government Requirements

Certain governments require that instructions pertaining to connection to the telephone network be included in the installation and operation manual. Specific instructions are listed in the following sections.

Notice to Users of the Canadian Telephone Network

The Industry Canada label identifies certified equipment. This certification means that the equipment meets telecommunications network protective, operational and safety requirements as prescribed in the appropriate Terminal Equipment Technical Requirements document(s). The Department does not guarantee the equipment will operate to the user's satisfaction.

Before installing this equipment, users should ensure that it is permissible to be connected to the facilities of the local telecommunications company. The equipment must also be installed using an acceptable method of connection. The customer should be aware that compliance with the above conditions may not prevent degradation of service in some situations.

Repairs to certified equipment should be coordinated by a representative designated by the supplier. Any repairs or alterations made by the user to this equipment, or equipment malfunctions, may give the telecommunications company cause to request to disconnect the equipment.

Users should ensure for their own protection that the electrical ground connections of the power utility, telephone lines and internal metallic water pipe system, if present, are connected together. This precaution may be particularly important in rural areas.

CAUTION:

Users should not attempt to make such connections themselves, but should contact the appropriate electric inspection authority, or electrician, as appropriate.

The Ringer Equivalence Number (REN) assigned to each terminal device provides an indication of the maximum number of terminals allowed to be connected to a telephone interface. The termination on an interface may consist of any combination of devices subject only to the requirement that the sum of the Ringer Equivalence Numbers of all the devices does not exceed 5.

If your equipment is in need of repair, refer to *Warranty, Sales, Service, and Training Information* on page 19.

Warranty, Sales, Service, and Training Information

Contact your local sales representative, service representative, or distributor directly for any help needed. For additional information concerning warranty, sales, service, repair, installation, documentation, training, distributor locations, or Paradyne worldwide office locations, use one of the following methods:

- **Internet:** Visit the Paradyne World Wide Web site at www.paradyne.com. (Be sure to register your warranty at www.paradyne.com/warranty.)
- **Telephone:** Call our automated system to receive current information by fax or to speak with a company representative.
 - Within the U.S.A., call 1-800-870-2221
 - Outside the U.S.A., call 1-727-530-2340

Document Feedback

We welcome your comments and suggestions about this document. Please mail them to Technical Publications, Paradyne Corporation, 8545 126th Ave. N., Largo, FL 33773, or send e-mail to userdoc@paradyne.com. Include the number and title of this document in your correspondence. Please include your name and phone number if you are willing to provide additional clarification.

Trademarks

Hotwire and MVL are registered trademarks of Paradyne Corporation. ReachDSL is a trademark of Paradyne Corporation. All other products and services mentioned herein are the trademarks, service marks, registered trademarks, or registered service marks of their respective owners.

Patent Notification

Hotwire MVL products are protected by U.S. Patents: 4,669,090, 4,744,092, 5,291,521, 5,805,669, and 5,848,150. Other U.S. and foreign patents pending.