

Hotwire® 6371 RADSL Router Installation Instructions

Document Number 6371-A2-GN10-40

September 2001

Contents

Hotwire 6371 RADSL Router Overview	1
Product Documentation Online	4
Getting Started	5
Installing DSL Access Wiring	6
Connecting to the DSL Access Wiring	8
Installing the Hotwire 6371 RADSL Router	9
Power-On	14
Troubleshooting	15
Configuration Setup	16
RADSL Router Technical Specifications	22
Cables and Connectors	17
Optional Wall Placement	20
Important Safety Instructions	23
Government Requirements	24
Warranty, Sales, Service, and Training Information	28

Hotwire 6371 RADSL Router Overview

The Hotwire® 6371 RADSL (Rate Adaptive Digital Subscriber Line) Router is a component in the Hotwire DSL Access system, which interoperates with Hotwire 8373, 8374, and 8510 RADSL line cards in the DSLAM (Digital Subscriber Line Access Multiplexer) system.

The router operates as an IP router, connecting a DSL link to an Ethernet network to provide high-speed Internet or corporate LAN access over traditional twisted-pair copper telephone wiring. Copper pairs run from the central office to the customer premises to create the local loop. The local loop terminates on the customer premises at the demarcation point in a punchdown block or network interface device (NID).

DSL Access without a POTS Splitter

When the router is installed without a POTS splitter, the DSL line is used for data only; it does not provide telephone services.

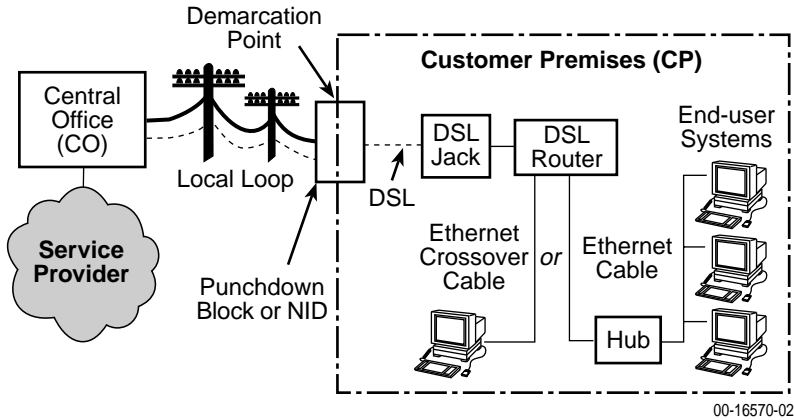

DSL – Digital Subscriber Line - - - - - New Wiring Connections
 NID – Network Interface Device

Phone Filters

For optimum performance, if the wiring for the router is also used for voice (POTS), a phone filter should be installed on each voice line with a phone, modem, fax machine, or other telecommunications device attached. One Hotwire phone filter can be used with multiple telecommunications devices (for example, a phone and fax machine can be supported using a single filter) if a multiple line adapter is used.

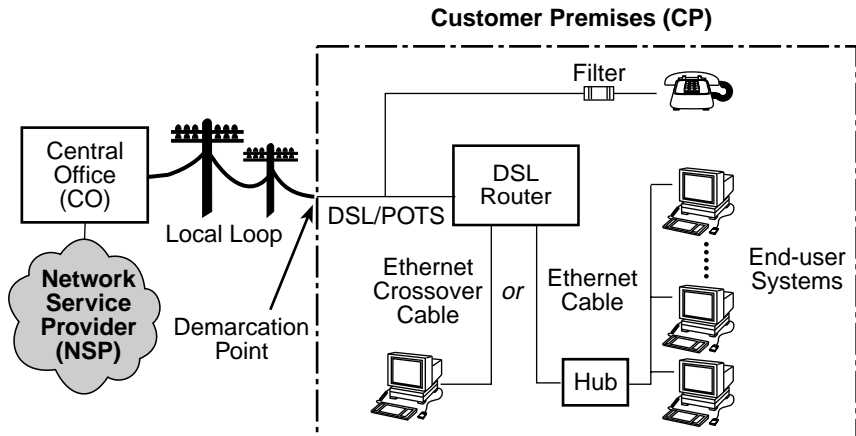

DSL – Digital Subscriber Lines
 POTS – Plain Old Telephone Service

There are two Hotwire phone filters that can be used with the RADSL Router:

- Hotwire 6035 Universal Phone Filter is designed for use with a tabletop phone.
- Hotwire 6040 Universal Wall Jack Phone Filter is designed for use with a wall phone.

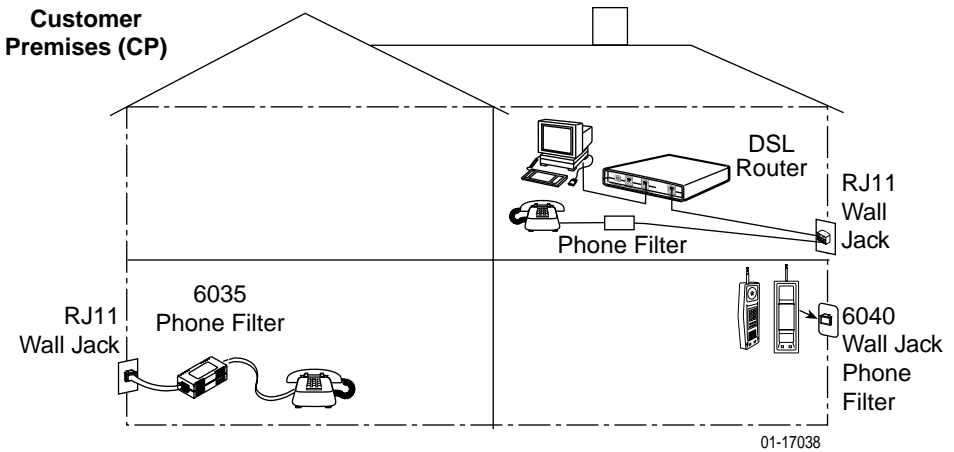

Product Documentation Online

Complete documentation for this product is available at www.paradyne.com.
Select *Library* → *Technical Manuals* → *Hotwire DSL Systems*.

For more information about Hotwire DSL Routers, refer to the following document:

6371-A2-GB20 *Hotwire DSL Routers User's Guide*

To install a POTS splitter or phone filter, refer to the appropriate document:

5030-A2-GN10 *Hotwire 5030 POTS Splitter Customer Premises Installation Instructions*

6035-A2-GN11 *Hotwire 6035 Universal Phone Filter Installation Instructions*

6040-A2-GN11 *Hotwire 6040 Universal Wall Jack Phone Filter Installation Instructions*

To order a paper copy of a Paradyne document:

- Within the U.S.A., call 1-800-PARADYNE (1-800-727-2396)
- Outside the U.S.A., call 1-727-530-8623

Getting Started

Before beginning your router's installation, make sure that you have all the equipment you will need.

Package Checklist

In addition to these instructions, verify that your package contains the following:

- Hotwire 6371 RADSL Router
- DSL interface cable with RJ11 modular plugs
- Power cord with power transformer

Wiring and Connectors You Will Need

The following wiring and standard connectors are used with this product:

- Standard RJ11 wall jack for the DSL cable.
- Multiple line adapter if a telephone and router are connected in the same location.
- DSL wiring: Unshielded twisted-pair wiring (CAT3, or better). The CAT3 wiring must meet EIA/TIA-568 specifications, with 24 AWG (.5 mm) or 26 AWG (.4 mm).
- Ethernet wiring: Shielded twisted-pair wiring (CAT5, or better). The CAT5 wiring must meet EIA/TIA-568 specifications, with 24 AWG (.5 mm) or 26 AWG (.4 mm). A straight-through or crossover Ethernet cable is used.

Refer to procedures in [Installing the Hotwire 6371 RADSL Router](#) on page 9 to install cables.

Optional Console Cable and Adapter

The Hotwire 6371 RADSL Router is typically configured remotely by the service provider. The following optional cable and adapters are only used to configure the router locally:

- Console cable: Straight-through cable with 8-pin non-keyed modular plugs (Part No. 035-0276-1431)
- Console adapter:
 - 8-pin modular-to-DB9 adapter plug (Part No. 002-0093-0031), or
 - A configurable DB9-to-RJ45 adapter, wired as shown in [8-Pin Modular to DB9 Adapter Plug](#) on page 19.

Installing DSL Access Wiring

The local loop terminates at the punchdown block or NID. Wiring must be connected from the customer premises side of the punchdown block or NID to an RJ11 jack. Typically, the punchdown block is installed in commercial locations and the NID is installed in residential locations.

► Procedure

1. Access the punchdown block or NID.
2. Disconnect the DSL access pair from the local loop.

⚠ WARNING:

Do not continue unless the DSL access line from the local loop has been disconnected at the NID or punchdown block. Refer to [Important Safety Instructions](#) on page 23.

The following example shows a punchdown block without POTS.

Punchdown Block

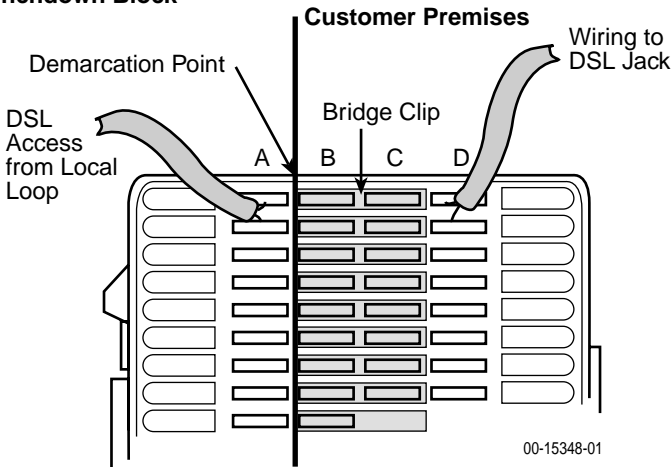

3. Locate the DSL pair of T1/R1 connectors on the customer premises side of the NID or punchdown block. Attach the wiring that will be connected to the DSL jack.

The following example shows a NID without a POTS splitter. It includes an existing POTS pair, and a second DSL pair is installed for DSL access.

Telephone Network Interface Device (NID)

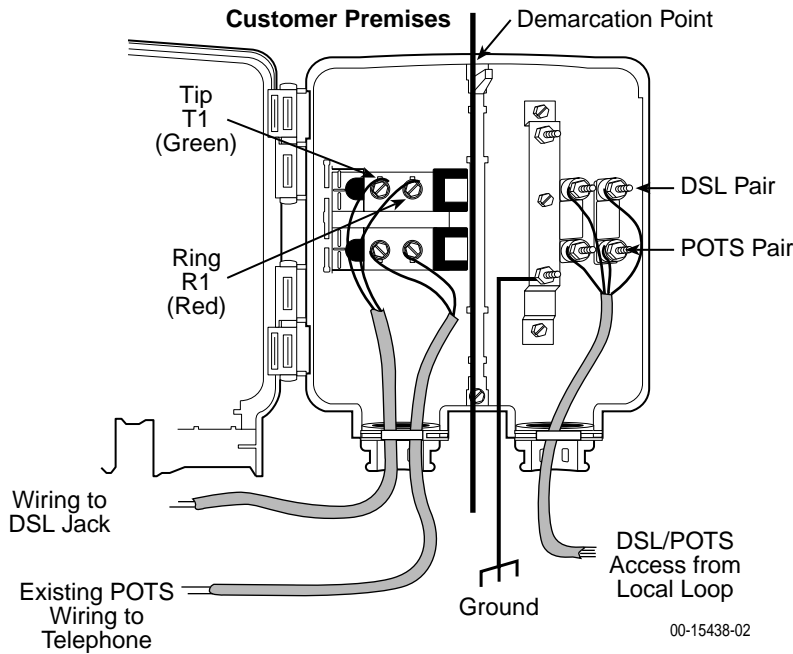

Connecting to the DSL Access Wiring

The Hotwire 6371 RADSL Router connects to the local loop via wiring from the demarcation point to an RJ11 wall jack. The DSL twisted-pair wiring from the local loop terminates at a new or existing wall jack. It may be necessary to install a standard single RJ11 jack or replace a single jack with a double RJ11 jack.

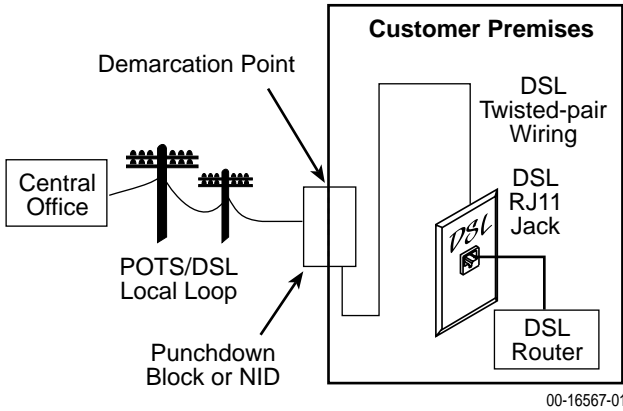

► Procedure

1. Wiring can be run from the punchdown block or NID to a new or existing wall jack. Match the pair colors on both ends.
2. Label the DSL jack.
3. Reconnect the DSL access pair at the punchdown block or NID. Tighten both terminal screws with a flat-blade screwdriver.

RJ11 Wall Jack

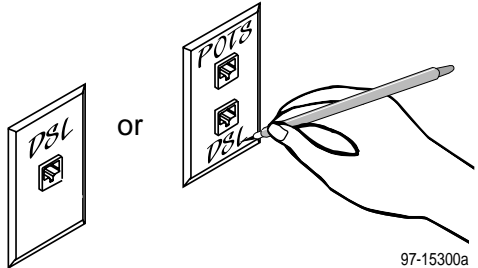

The RJ11 6-pin jack uses the two center pins. For pin assignments, refer to [Cables and Connectors](#) on page 17.

Installing the Hotwire 6371 RADSL Router

Place the RADSL router on a flat surface, with clearance for the rear connectors. For router cable pin assignments, refer to *Cables and Connectors* on page 17.

Connecting the DSL Line in a Home Environment (Phone and Router in the Same Location)

For the DSL connection, use the supplied RJ11 6-pin cable. You will also need a multiple line adapter and a filter (see *Phone Filters* on page 3).

► Procedure

1. Insert a multiple line adapter into the wall jack.
2. Insert one end of the cable into the **DSL** jack on the router.
3. Insert the other end of the cable into one of the jacks (**Line 1** or **Line 2**) on the multiple line adapter.
4. Insert the line cord from the **LINE** jack on the filter into the empty jack on the multiple line adapter.
5. Insert the phone line cord from the phone into the **PHONE** jack on the filter.

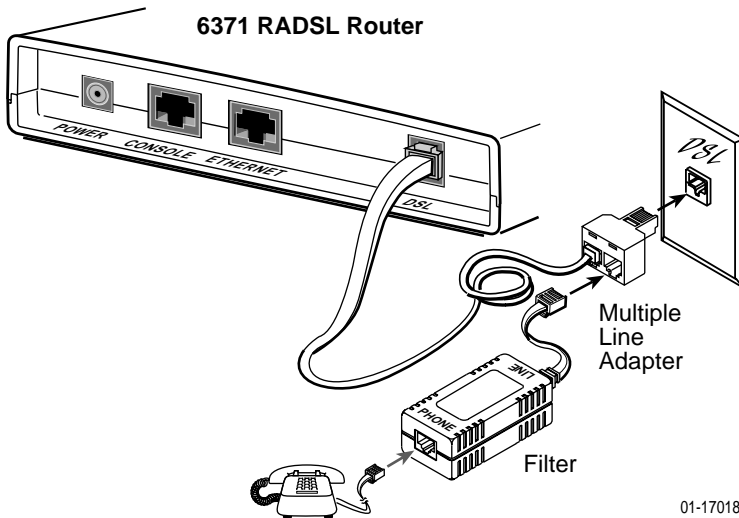

01-17018

Connecting the DSL Line in All Other Environments

Use the supplied RJ11 6-pin cable for the DSL connection.

► Procedure

1. Insert one end of the cable into the **DSL** jack on the router.
2. Insert the other end of the cable into the wall jack.

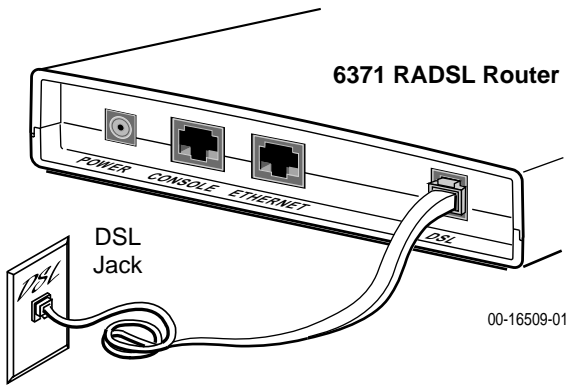

Connecting the Ethernet Cable

Use an 8-pin Ethernet straight-through or crossover cable for the Ethernet connection.

► Procedure

To connect an Ethernet Hub using a straight-through cable:

- Insert one end of the straight-through cable into the **ETHERNET** jack on the router and connect the other end to an Ethernet hub. Do not connect it to the hub's optional Uplink connection; the Uplink connection requires an Ethernet crossover cable. To support multiple end-user systems, refer to [Increasing the Number of End-User Systems](#) on page 16.

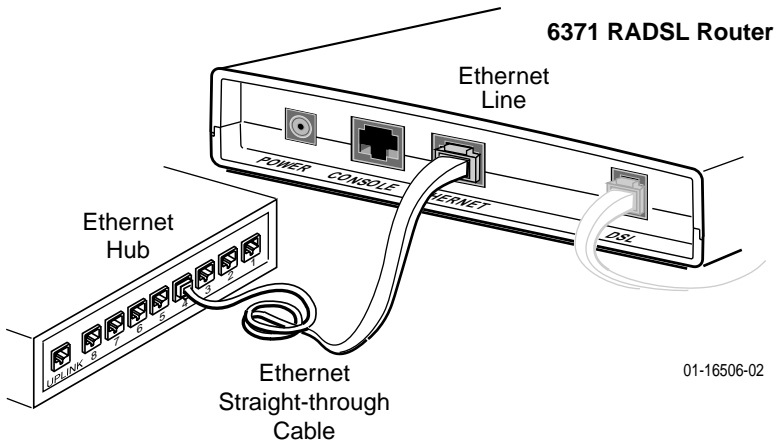

To connect a PC using a crossover cable:

- Insert one end of the crossover cable into the **ETHERNET** jack on the router and connect the other end of the cable to a PC with an Ethernet Network Interface Card (NIC) installed.

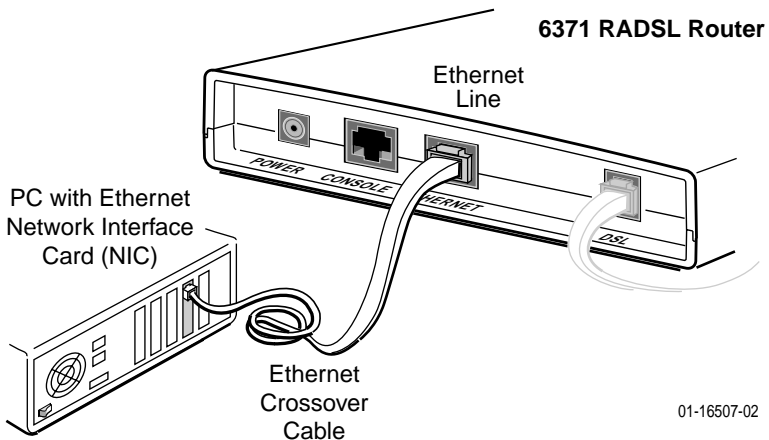

Connecting to a VT100 Terminal or PC (Optional)

The Console port acts as a DCE and uses an 8-pin straight-through cable for the connection to a VT100-compatible terminal or a PC running a terminal emulation program. It is an optional connection that is only used for local configuration of the router.

To set up the VT100 terminal or PC for local configuration and to access the router, refer to [Configuration Setup](#) and [Accessing the Router](#) on page 16.

► Procedure

1. Connect a DB9 adapter to the PC.
2. Insert one end of the cable into the DB9 adapter for the serial port of the VT100 terminal or PC.
3. Insert the other end of the cable into the **CONSOLE** jack on the router.

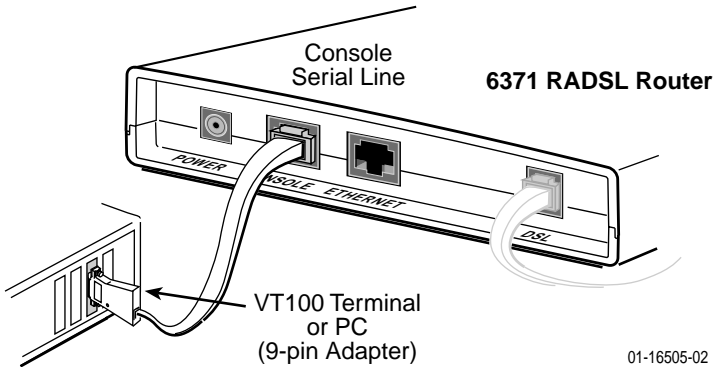

01-16505-02

Connecting Power

► Procedure

1. Insert the supplied power cord's round end into the **POWER** jack on the router.
2. Plug the transformer into an AC outlet.

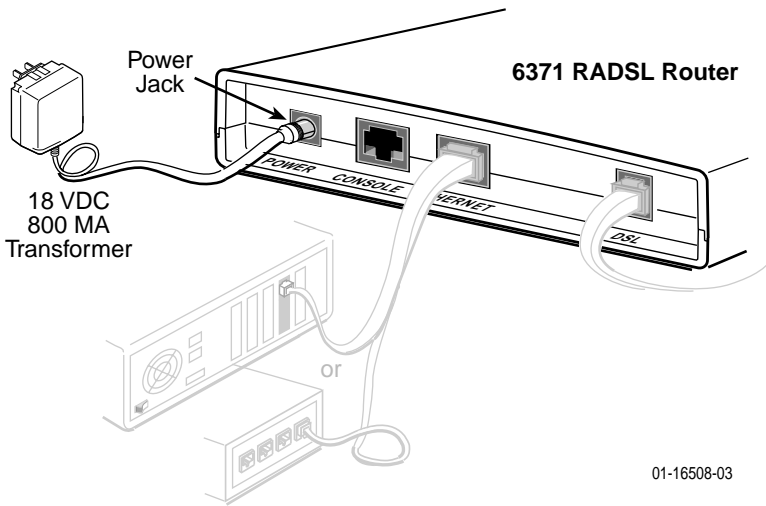

01-16508-03

Installation of the hardware is now complete. When the power cord is installed, the router goes through a power-on self-test.

Power-On

When power is applied, the router performs self-diagnostics and the PWR LED is on. The self-diagnostics includes a power-on self-test. During the power-on self-test, all of the LEDs turn on for one second.

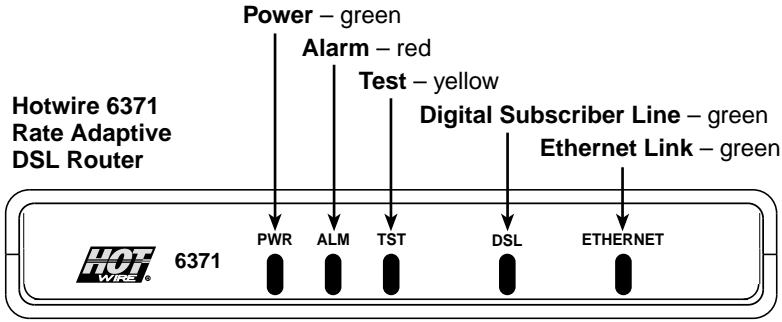

00-16502-01

Status LEDs

After a successful self-test, the LEDs should appear as indicated in **BOLD** in the Condition column below. Refer to [Troubleshooting](#) on page 15 for LED indications requiring action.

LED	Condition	Status
PWR	ON	The router has power.
ALM	Blinking	A firmware download is in progress. The TST LED is also on during a download.
	ON	An alarm condition exists.
	OFF	No alarms have been detected by the router.
TST	ON	The TST LED is on during the power-on self-test, during a test initiated by the service provider, and during a firmware download.
	OFF	No tests are active.
DSL	Blinking	The router is establishing the active DSL link. The LED blinks on and off about five times per second.
	ON	The DSL link is ready to transmit and receive data.
	OFF	No DSL link has been established.
ETHERNET	ON	The Ethernet connection is active.
	OFF	No Ethernet device is detected.

Troubleshooting

LED Symptom	Action
All LEDs are on.	If the LEDs remain on for more than ten minutes, the router is not functional. Contact the service provider.
ALM LED remains on.	The power-on self-test may have failed. Unplug the router and reapply power. If the alarm LED is still on, contact the service provider.
ALM and TST LEDs are blinking.	A firmware download may be in progress. If a firmware download is not in progress, or if the LEDs continue blinking for more than ten minutes, contact the service provider.
DSL LED is off.	Verify that the DSL cable is securely installed at both ends. If the problem continues, contact the service provider.
DSL LED continues to blink after the power-on self-test.	The router is attempting to establish the DSL link or adjusting the DSL line rate due to line conditions. If the DSL LED continues to blink for more than ten minutes, contact the service provider.
DSL LED is on, but no data is being transmitted.	The DSL link has been established, but data is not being transmitted. Verify the Ethernet connection at both ends. If the problem persists, contact the service provider.
DSL and Ethernet LEDs are on, but no data is being transmitted.	Both the DSL and Ethernet links have been established, but data is not being transmitted. If the problem continues, contact the service provider.
Ethernet LED is off.	Verify that the Ethernet cable is securely installed at both ends, and at least one PC is connected and powered on.
	Verify that the correct straight-through or crossover cable is installed. Refer to Connecting the Ethernet Cable on page 11.
PWR LED is off.	Check that the power cord is securely installed on both ends.
	If no LEDs are on, the power supply may be defective. Test the outlet to verify power.
	If other LEDs are on, the PWR LED may be burned out. Unplug the unit and reapply power; watch all LEDs during the power-on self-test to verify that the PWR LED is functioning. If the problem persists, contact the service provider.
TST LED is on.	A test initiated by the service provider may be active. Wait ten minutes. If the TST LED does not go off, contact the service provider.

Configuration Setup

Connection to a VT100-compatible terminal or a PC running terminal emulation is optional. It is used to configure the router locally, rather than the service provider configuring the router remotely. Refer to [Connecting to a VT100 Terminal or PC \(Optional\)](#) on page 12 to connect the router to a terminal or PC.

For local configuration, verify the following terminal or PC settings:

- Data rate is set to 19.2 Kbps (19200 bps).
- Character length is set to 8.
- Parity is set to None.
- Stop bits is set to 1.
- Flow control is set to Off or None.

Accessing the Router

When the local console connection is first established, access control to the RADSL router displays an initial prompt of **Login>**.

► Procedure

1. At the initial prompt of **Login>**, enter the factory default Login ID of **paradyne**.
2. At the **password>** prompt, enter the factory default Password of **abc123**.
3. At the next prompt for System ID, the factory default is **CUSTOMER>**.

Optionally, enter **show system** to display hardware/firmware information and Selftest Results.

Refer to the *Hotwire DSL Routers User's Guide* for configuration settings and command line entries.

Increasing the Number of End-User Systems

The router can support differing numbers of end-user systems, depending upon the functions that are enabled and traffic loading. Typical configurations provide support for up to 32, 64, or 256 hosts (end-user systems).

An Ethernet crossover cable is used when a single PC is connected to the router. To increase the number of PCs, connect all PCs to an Ethernet hub using a straight-through cable. Increase the number of end-user systems by using subnets that utilize static addressing, or by using a default gateway connection.

Refer to [Connecting the Ethernet Cable](#) on page 11 to connect the router to multiple end-user systems or a single PC.

Cables and Connectors

This section is reference information.

Use a CAT3, or better, cable for the DSL line.

- The DSL interface uses a 6-pin, non-keyed modular plug.

RJ11 6-Pin Connector

Pin #	Function
1 & 2	Not used
3	DSL Ring
4	DSL Tip
5 & 6	Not used

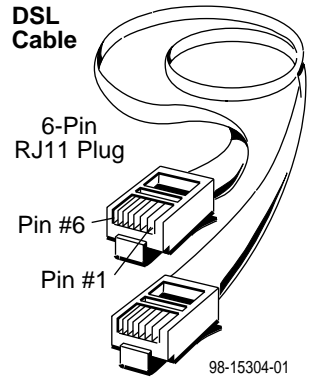

- The Ethernet interface connector uses an 8-pin, non-keyed modular plug. Use shielded twisted-pair CAT5, or better, cables.
 - To connect the router to an Ethernet hub, use a straight-through connection.

8-Pin Straight-through Connection

Pin #	Function
1	10/100BaseT TX D+
2	10/100BaseT TX D-
3	10/100BaseT RX D+
4 & 5	Not used
6	10/100BaseT RX D-
7 & 8	Not used

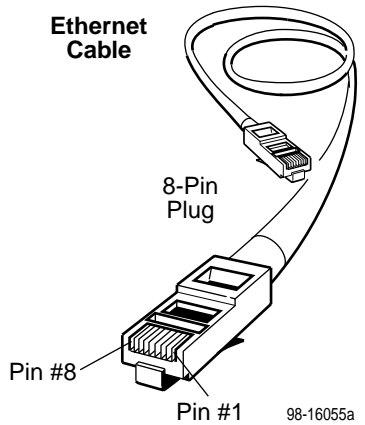

— or —

- To connect the router to a PC with an Ethernet NIC card, use an Ethernet crossover cable.

8-Pin Ethernet Crossover Cable

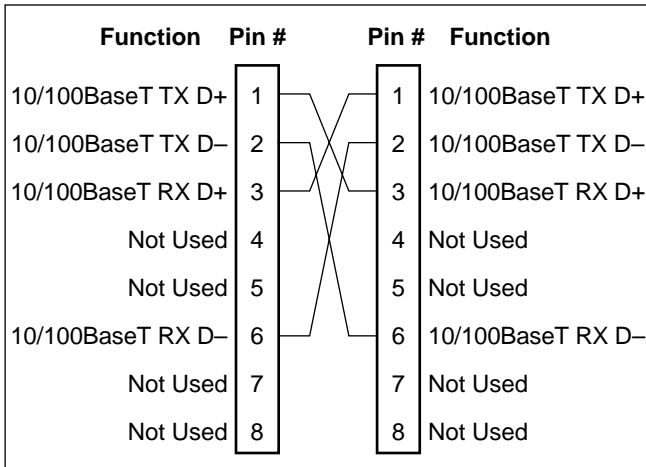

Pin #1/2 = Orange/White Twisted Pair

Pin #3/6 = Blue/White Twisted Pair

99-16518

- The Console connector uses 8-pin, non-keyed modular plugs and a DB9 adapter.

RJ45 8-Pin Connector

Pin #	Circuit	Direction
1	Not used	—
2	DTR	Input to Console port
3	TXD	Input
4 & 5	Signal Ground	—
6	RXD	Output
7	DSR	Output
8	Not used	—

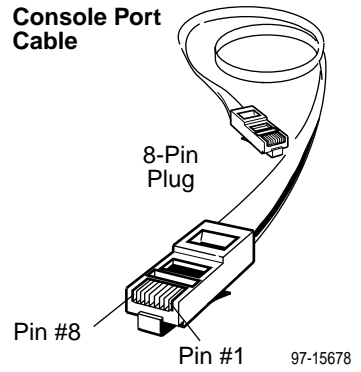

8-Pin Modular to DB9 Adapter Plug

Modular Pin #	Circuit	DB9 Pin #
1	RTS	7
2	DTR	4
3	TXD	3
4 & 5	Signal Ground	5
6	RXD	2
7	DSR	6
8	CTS	8

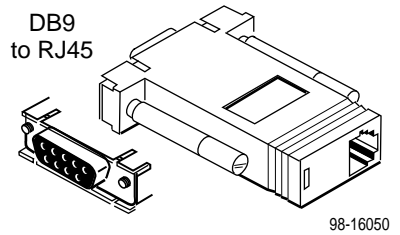

Optional Wall Placement

The Hotwire 6371 RADSL Router is designed for tabletop placement. The RADSL router can also be mounted on a wall.

To mount the RADSL router, you will need:

- Three #6 pan-head screws with anchors (for example, molly bolts, plastic or lead anchors)
- Drill, and the correct size drill bit for the anchors
- Screwdriver

A template with the dimensions for the three screws is provided. See [RADSL Router Hardware Template](#) on page 21.

► Procedure

To mount the RADSL router:

1. Drill the correct size hole for the anchors and install them. Use the template to gauge their placement.
2. Screw the pan-head screws into the installed anchors. Do not make them flush with the wall. Leave enough clearance to hang the router housing from the screws.

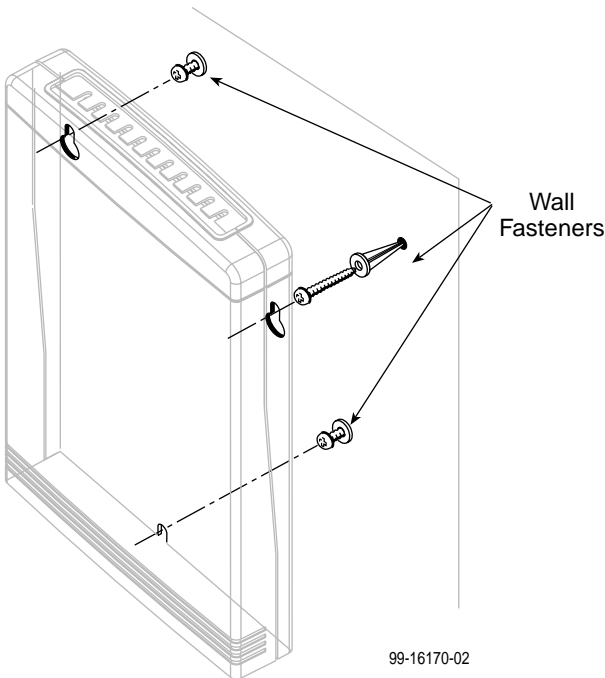

99-16170-02

RADSL Router Hardware Template

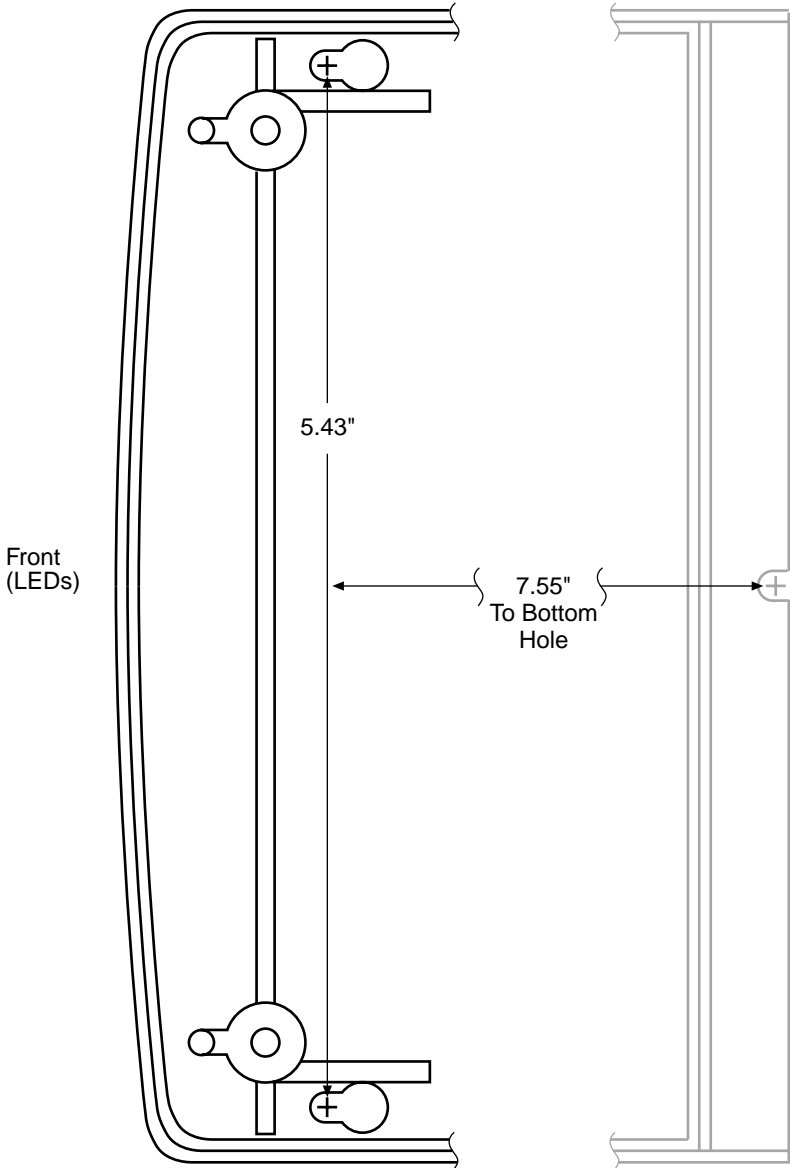

RADSL Router Technical Specifications

Item	Specification*
Height x Width x Depth With Feet Without Feet	1.43" x 6.00" x 8.75" (3.64 cm x 15.24 cm x 22.23 cm) 1.25" x 6.00" x 8.75" (3.15 cm x 15.24 cm x 22.23 cm)
Weight	1 lb. 1 oz. (0.48 kg)
External Power Supply Class 2 Transformer normal service input voltage range	Input: 100 VAC ($\pm 10\%$), 50 Hz; 120 VAC ($\pm 10\%$), 60 Hz; or 230 VAC ($\pm 10\%$), 50/60 Hz Output: 18 VDC nominal at 0.8A
Unit Power Consumption	5.5 watts (nominal)
Approvals FCC Part 15 CISPR 22 Safety Certifications	Class B Subpart B digital device Class B Refer to equipment's label for approvals on product.
Physical Environment Operating temperature Storage temperature Relative humidity Shock and vibration	32°F to 104°F (0°C to 40°C) -4°F to 158°F (-20°C to 70°C) 5% to 95% (noncondensing) Withstands normal shipping and handling
Interface Connectors DSL Interface Console Interface Ethernet Type II Frame	RJ11 6-pin 8-pin 10/100BaseT 8-pin

* Technical Specifications are subject to change without notification.

⚠ Important Safety Instructions

1. Read and follow all warning notices and instructions marked on the product or included in the manual.
2. Slots and openings in the cabinet are provided for ventilation. To ensure reliable operation of the product and to protect it from overheating, these slots and openings must not be blocked or covered.
3. Do not allow anything to rest on the power cord and do not locate the product where persons will walk on the power cord.
4. Do not attempt to service this product yourself, as opening or removing covers may expose you to dangerous high voltage points or other risks. Refer all servicing to qualified service personnel.
5. General purpose cables are used with this product for connection to the network. Special cables, which may be required by the regulatory inspection authority for the installation site, are the responsibility of the customer. Use a UL Listed, CSA certified, minimum No. 24 AWG line cord for connection to the Digital Subscriber Line (DSL) network.
6. When installed in the final configuration, the product must comply with the applicable Safety Standards and regulatory requirements of the country in which it is installed. If necessary, consult with the appropriate regulatory agencies and inspection authorities to ensure compliance.
7. A rare phenomenon can create a voltage potential between the earth grounds of two or more buildings. If products installed in separate buildings are **interconnected**, the voltage potential may cause a hazardous condition. Consult a qualified electrical consultant to determine whether or not this phenomenon exists and, if necessary, implement corrective action prior to interconnecting the products.
8. Input power to this product must be provided by one of the following: (1) a UL Listed/CSA certified power source with a Class 2 or Limited Power Source (LPS) output for use in North America, or (2) a certified transformer, with a Safety Extra Low Voltage (SELV) output having a maximum 240 VA available, for use in the country of installation.
9. In addition, since the equipment is to be used with telecommunications circuits, take the following precautions:
 - Never install telephone wiring during a lightning storm.
 - Never install telephone jacks in wet locations unless the jack is specifically designed for wet locations.
 - Never touch uninsulated telephone wires or terminals unless the telephone line has been disconnected at the network interface.
 - Use caution when installing or modifying telephone lines.
 - Avoid using a telephone (other than a cordless type) during an electrical storm. There may be a remote risk of electric shock from lightning.
 - Do not use the telephone to report a gas leak in the vicinity of the leak.

CANADA – EMI NOTICE:

This Class B digital apparatus meets all requirements of the Canadian interference-causing equipment regulations.

Cet appareil numérique de la classe B respecte toutes les exigences du règlement sur le matériel brouilleur du Canada.

Government Requirements

Certain governments require that instructions pertaining to connection to the telephone network be included in the installation and operation manual. Specific instructions are listed in the following sections.

United States – Notice to Users of the Telephone Network

1. This equipment complies with Part 68 of the FCC rules. On the equipment is a label that contains, among other information, the FCC registration number and ringer equivalence number (REN) for this equipment. The label is located on the bottom of your RTU.
2. The Hotwire 6371 RADSL Router connects to the Public Switched Telephone Network (PSTN) using the Universal Service Order Code (USOC) RJ11C or RJ14C.
3. The Ringer Equivalence (REN) is used to determine the quantity of devices which may be connected to the telephone line. Excessive RENs on the telephone line may result in the devices not ringing in response to an incoming call. In most, but not all areas, the sum of the RENs should not exceed five (5.0). To be certain of the number of devices that may be connected to the line, as determined by the total RENs, contact the telephone company to determine the maximum RENs for the calling area.
4. If the DSL router causes harm to the telephone network, the telephone company will notify you in advance that temporary discontinuance of service may be required. But if advance notice is not practical, the telephone company will notify the customer as soon as possible. Also, you will be advised of your right to file a complaint with the FCC if you believe it is necessary.
5. The telephone company may make changes in its facilities, equipment, operations, or procedures that could affect the operation of the equipment. If this happens, the telephone company will provide advance notice in order for you to make the necessary modifications in order to maintain uninterrupted service.
6. If you experience trouble with this equipment, please contact your sales or service representative (as appropriate) for repair or warranty information. If the product needs to be returned to the company service center for repair, contact them directly for return instructions using one of the following methods:

-
- **Internet:** Visit the Paradyne World Wide Web site at **www.paradyne.com**.
 - **Telephone:** Call our automated system to receive current information via fax or to speak with a company representative.

Within the U.S.A., call 1-800-870-2221

Outside the U.S.A., call 1-727-530-2340

If the trouble is causing harm to the telephone network, the telephone company may request that you remove the equipment from the network until the problem is resolved.

7. The user is not authorized to repair or modify the equipment.
8. This equipment cannot be used on public coin service provided by the telephone company. Connection to Party Line Service is subject to state tariffs. (Contact the state public utility commission, public service commission or corporation commission for information.)
9. An FCC compliant telephone cord with modular plugs may be provided with this equipment. This equipment is designed to be connected to the telephone network or premises wiring using a compatible modular jack which is Part 68 compliant.

Notice to Users of the Canadian Telephone Network

The Industry Canada label identifies certified equipment. This certification means that the equipment meets telecommunications network protective, operational and safety requirements as prescribed in the appropriate Terminal Equipment Technical Requirements document(s). The Department does not guarantee the equipment will operate to the user's satisfaction.

Before installing this equipment, users should ensure that it is permissible to be connected to the facilities of the local telecommunications company. The equipment must also be installed using an acceptable method of connection. The customer should be aware that compliance with the above conditions may not prevent degradation of service in some situations.

Repairs to certified equipment should be coordinated by a representative designated by the supplier. Any repairs or alterations made by the user to this equipment, or equipment malfunctions, may give the telecommunications company cause to request to disconnect the equipment.

Users should ensure for their own protection that the electrical ground connections of the power utility, telephone lines and internal metallic water pipe system, if present, are connected together. This precaution may be particularly important in rural areas.

CAUTION:

Users should not attempt to make such connections themselves, but should contact the appropriate electric inspection authority, or electrician, as appropriate.

The Ringer Equivalence Number (REN) assigned to each terminal device provides an indication of the maximum number of terminals allowed to be connected to a telephone interface. The termination on an interface may consist of any combination of devices subject only to the requirement that the sum of the Ringer Equivalence Numbers of all the devices does not exceed 5.

If your equipment is in need of repair, refer to [Warranty, Sales, Service, and Training Information](#) on page 28.

Declaration of Conformity

This Declaration of Conformity is made by Paradyne Corporation pursuant to Parts 2 and 15 of the Federal Communications Commission's Rules. This compliance information statement pertains to the following products:

Trade Name: Hotwire
Model Number: 6371-A1-200

This device complies with Part 15 of the FCC Rules. Operation is subject to the following two conditions: (1) this device may not cause harmful interference, and (2) this device must accept any interference received, including interference that may cause undesired operation.

The name, address, and telephone number of the responsible party is given below:

Paradyne Corporation
8545 126th Avenue North
Largo, FL 33773-1502
Phone: (727) 530-2000

The authority to operate this equipment is conditioned by the requirement that no modifications will be made to the equipment unless the changes or modifications are expressly approved by Paradyne Corporation.

This equipment has been tested and found to comply with the limits for a Class B digital device, pursuant to Part 15 of the FCC Rules. These limits are designed to provide reasonable protection against harmful interference in a residential installation. This equipment generates, uses, and can radiate radio frequency energy and, if not installed and used in accordance with the instructions, may cause harmful interference to radio communications. However, there is no guarantee that interference will not occur in a particular installation. If this equipment does cause harmful interference to radio or television reception, which can be determined by turning the equipment off and on, the user is encouraged to try to correct the interference by one or more of the following measures:

- Reorient or relocate the receiving antenna.
- Increase the separation between the equipment and receiver.
- Connect the equipment into an outlet on a circuit different from that to which the receiver is connected.
- Consult the dealer or an experienced radio/TV technician for help.

Japan – Notices

この装置は、情報処理装置等電波障害自主規制協議会（VCCI）の基準に基づくクラス B 情報技術装置です。この装置は、家庭環境で使用することを目的としていますが、この装置がラジオやテレビジョン受信機に近接して使用されると、受信障害を引き起こすことがあります。

取扱説明書に従って正しい取り扱いをして下さい。

This is a Class B product based on the standard of the Voluntary Control Council for Interference from Information Technology Equipment (VCCI). If this is used near a radio or television receiver in a domestic environment, it may cause radio interference. Install and use the equipment according to the instruction manual.

CE Marking

When the product is marked with the CE mark on the equipment label, this demonstrates full compliance with the following European Directives:

- **Directive 73/23/EEC** – Council Directive of 19 February 1973 on the harmonization of the laws of the member states relating to electrical equipment designed for use within states relating to electrical equipment designed for use within certain voltage limits, as amended by Directive 93/68/EEC.
- **Directive 89/336/EEC** – Council Directive of 3 May 1989 on the approximation of the laws of the member states relating to Electro-Magnetic Compatibility (EMC), as amended by Directive 93/68/EEC.

Warranty, Sales, Service, and Training Information

Contact your local sales representative, service representative, or distributor directly for any help needed. For additional information concerning warranty, sales, service, repair, installation, documentation, training, distributor locations, or Paradyne worldwide office locations, use one of the following methods:

- **Internet:** Visit the Paradyne World Wide Web site at **www.paradyne.com**. (Be sure to register your warranty at **www.paradyne.com/warranty**.)
- **Telephone:** Call our automated system to receive current information by fax or to speak with a company representative.
 - Within the U.S.A., call 1-800-870-2221
 - Outside the U.S.A., call 1-727-530-2340

Document Feedback

We welcome your comments and suggestions about this document. Please mail them to Technical Publications, Paradyne Corporation, 8545 126th Ave. N., Largo, FL 33773, or send e-mail to **userdoc@paradyne.com**. Include the number and title of this document in your correspondence. Please include your name and phone number if you are willing to provide additional clarification.

Trademarks

Hotwire is a registered trademark of Paradyne Corporation. All other products and services mentioned herein are the trademarks, service marks, registered trademarks, or registered service marks of their respective owners.



6371-A2-GN10-40