



SuperLine™ Adapter Installation Instructions

Document Number 6512-A2-GN10-20

January 1999

SuperLine™ Adapter

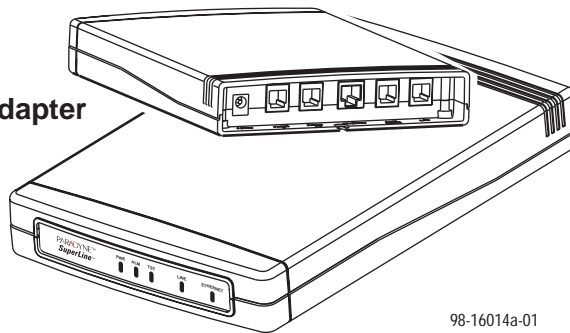

98-16014a-01

Contents:

- Important Safety Instructions
- What Your SuperLine Adapter Does
- Package Checklist
- Optional Hardware (Not Supplied)
- Front Panel Indicators
- SuperLine Adapter Rear Panel
- Installing Your SuperLine Adapter
- Troubleshooting Your Adapter
- Technical Information
- Technical Specifications
- Technical Support

⚠ Important Safety Instructions

1. Read and follow all warning notices and instructions marked on the product or included in the manual.
2. Slots and openings in the housing are provided for ventilation. To ensure reliable operation of the product and to protect it from overheating, these slots and openings must not be blocked or covered.
3. Do not allow anything to rest on the power cord and do not locate the product where people will walk on the power cord.
4. Do not attempt to service this product yourself, as opening or removing covers may expose you to dangerous high voltage points or other risks. Refer all servicing to qualified service personnel.
5. General purpose cables are used with this product for connection to the network. Special cables, which may be required by the regulatory inspection authority for the installation site, are the responsibility of the customer.
6. In addition, since the equipment is to be used with telecommunications circuits, take the following precautions:
 - Never install telephone wiring during a lightning storm.
 - Never install telephone jacks in wet locations unless the jack is specifically designed for wet locations.
 - Never touch uninsulated telephone wires or terminals unless the telephone line has been disconnected at the network interface.
 - Avoid using a telephone (other than a cordless type) during an electrical storm. There may be a remote risk of electric shock from lightning.
 - Do not use the telephone to report a gas leak in the vicinity of the leak.

Declaration of Conformity

This Declaration of Conformity is made by Paradyne pursuant to Parts 2 and 15 of the Federal Communications Commission's Rules. This compliance information statement pertains to the following products:

Trade Name: SuperLine™ Adapter
Model Number: 6512

This device complies with Part 15 of the FCC Rules. Operation is subject to the following two conditions: (1) this device may not cause harmful interference, and (2) this device must accept any interference received, including interference that may cause undesired operation.

The name and address of the responsible party is given below:

Paradyne Corporation
8345 126th Ave. N.
P.O. Box 2826
Largo, FL 33779-2826

The authority to operate this equipment is conditioned by the requirement that no modifications will be made to the equipment unless the changes or modifications are expressly approved by Paradyne Corporation.

Canada

WARNING:

To Users of Digital Apparatus in Canada:

This Class B digital apparatus meets all requirements of the Canadian interference-causing equipment regulations.

Cet appareil numérique de la classe B respecte toutes les exigences du règlement sur le matériel brouilleur du Canada.

Notice to Users of the Canadian Telephone Network

The Industry Canada label identifies certified equipment. This certification means that the equipment meets telecommunications network protective, operational and safety requirements as prescribed in the appropriate Terminal Equipment Technical Requirements document(s). The Department does not guarantee the equipment will operate to the user's satisfaction.

Before installing this equipment, users should ensure that it is permissible to be connected to the facilities of the local telecommunications company. The equipment must also be installed using an acceptable method of connection. The customer should be aware that compliance with the above conditions may not prevent degradation of service in some situations.

Repairs to certified equipment should be coordinated by a representative designated by the supplier. Any repairs or alterations made by the user to this equipment, or equipment malfunctions, may give the telecommunications company cause to request to disconnect the equipment.

Users should ensure for their own protection that the electrical ground connections of the power utility, telephone lines and internal metallic water pipe system, if present, are connected together. This precaution may be particularly important in rural areas.

CAUTION:

Users should not attempt to make such connections themselves, but should contact the appropriate electric inspection authority, or electrician, as appropriate.

The Ringer Equivalence Number (REN) assigned to each terminal device provides an indication of the maximum number of terminals allowed to be connected to a telephone interface. The termination on an interface may consist of any combination of devices subject only to the requirement that the sum of the Ringer Equivalence Numbers of all the devices does not exceed 5.

If your equipment is in need of repair, refer to *Technical Support* on page 28.

What Your SuperLine Adapter Does

Your SuperLine Adapter allows you to connect multiple phones, fax machines, or modems using your existing telephone wiring.

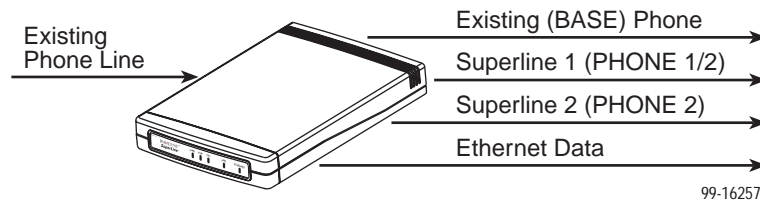

The SuperLine technology:

- Transforms your existing single phone line into multiple phone lines (superlines) to support up to two additional phones, fax machines, or modems simultaneously.
- Operates over your existing copper wire with your existing telephone jacks.
- Allows True56K™ V.90 modem connections supporting maximum 56K modem speeds on your superlines.
- Provides high-speed Internet access through an Ethernet connection. (Available in some areas. Ask your local telephone company about availability of this service.)
- Only operates with Touch Tone™ phones. The PHONE 1/2 and PHONE 2 jacks do not support pulse dial phones. (Your existing phone, plugged into the BASE PHONE jack, can be a pulse dial phone.)

NOTE:

Your local telephone company must enable these services and assign phone numbers to the additional phone lines before your SuperLine Adapter will work.

Your SuperLine Adapter connects to your existing phone line to provide up to two additional phone lines (superlines). These superlines support any combination of up to two phones, fax machines, or modems. Your SuperLine Adapter also allows True56K modem speeds with an International Telecommunications Union (ITU) V.90 standard modem. The following figure depicts a typical home or small office configuration with several existing phones and two superlines. Phone filters are connected to your existing phones to reduce the amount of interference generated during phone conversations.

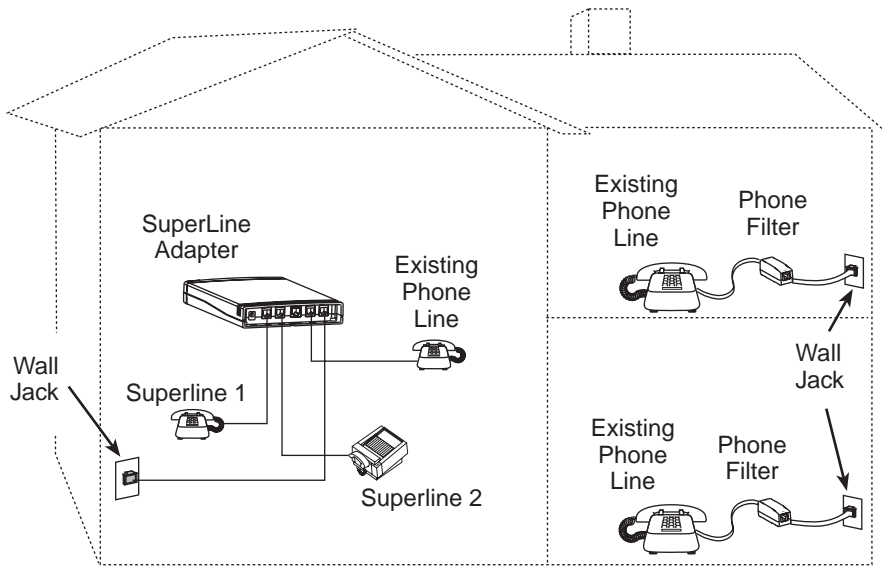

99-16018a-02

Package Checklist

Verify that your package contains the following hardware. If any hardware is missing or you need to order additional hardware, contact you local telephone company. Refer to *Technical Information* on page 25 for further information.

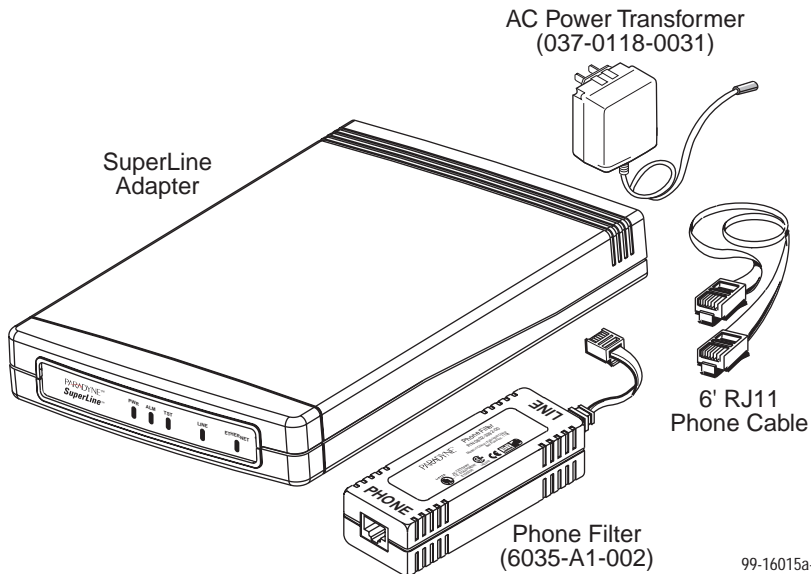

99-16015a-02

Optional Hardware (Not Supplied)

The following hardware may be required depending on which configuration you choose to install. You can purchase these items from your local electronics or phone store.

2-Line Phone Cable (RJ14C)

If you are connecting a 2-line phone, you may require a 2-line phone cable (24 AWG, RJ14C) as defined in *Connecting a 2-Line Phone (with Two Superlines)* on page 14. Refer to *Technical Information* on page 25 for the 2-line phone cable pin configuration.

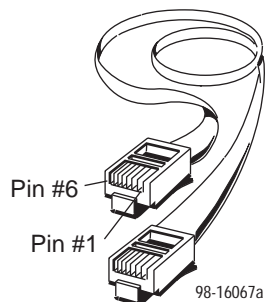

“T” Type Connector

If your home or office phone jacks are wired internally with 4 wires, you may be able to connect phones in other rooms to your SuperLine Adapter using a “T” type connector as defined in *Optional Configuration* on page 18. Refer to *“T” Type Connector* on page 27 for the “T” type connector pin configuration.

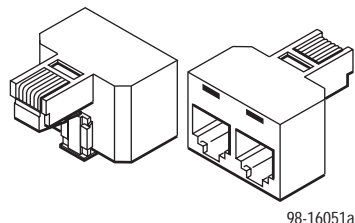

Front Panel Indicators

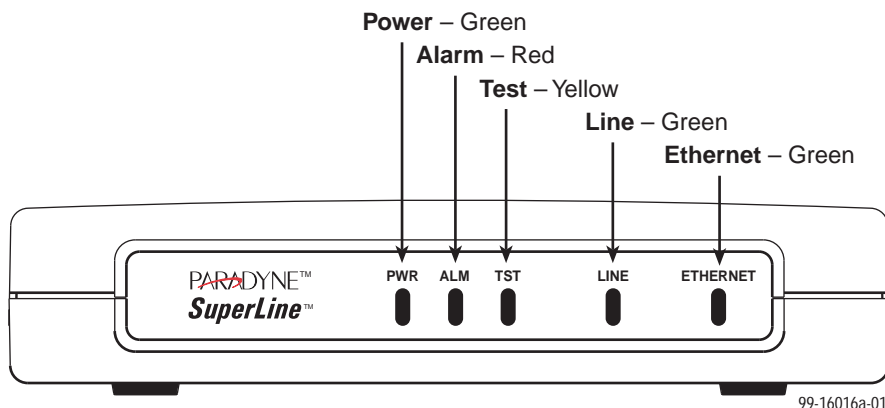

All of the adapter's indicators turn ON and OFF during the power-on self-test. After a successful power-on self-test, the adapter's indicators should appear as indicated in **BOLD** in the Condition column of the following table:

Indicator	Condition	Status
PWR	ON	Power is applied to the adapter.
ALM	OFF ON	No active alarms. An alarm condition exists which may require further attention. Refer to <i>Troubleshooting Your Adapter</i> on page 22.
TST	OFF ON	No active tests. The TST indicator is ON during the power-on self-test and during testing or upgrades initiated by your network service provider. Superline service is not available when the TST indicator is ON. Your existing (BASE) phone still works.
LINE	ON OFF	Your adapter is connected to your local phone company and is ready to use. The link has not been established.
ETHERNET	ON OFF	The Ethernet connection to your PC or Ethernet Hub is made and your PC is ON. No Ethernet device is detected.

Under normal operation, if the PWR and LINE indicators are on you should be able to access the superline service to which you have subscribed. The ETHERNET indicator state depends on the equipment you have connected to your adapter. The TST and ALM indicators can be initiated by your Network Service Provider. For conditions other than these, refer to *Troubleshooting Your Adapter* on page 22 for indicators requiring action.

SuperLine Adapter Rear Panel

The rear panel of your adapter has five jacks which allow you to:

- Connect your existing phone
- Connect up to two additional phones, fax machines, or modems
- Connect a PC or Hub for high-speed Ethernet data services
- Connect the supplied AC power supply

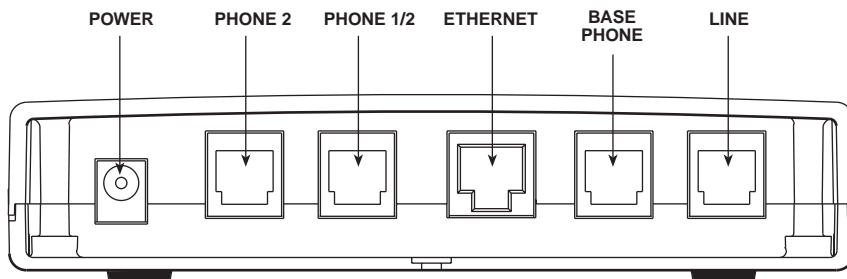

98-16095a

Rear Panel Jacks

This Jack	Allows You To
POWER	Apply power to your SuperLine Adapter.
PHONE 2 (superline 2)	Connect a phone, fax machine, or modem if you have purchased two superlines. This jack is not functional if you have only one superline through your SuperLine Adapter.
PHONE 1/2 (superline 1/2)	Connect a phone, fax machine, or modem if you have one or two superlines. This jack is also used to connect a 2-line phone with a single 2-line phone cable if you have purchased two superlines.
ETHERNET	Connect high-speed Ethernet data services. Ask your local phone company about the availability of high-speed Ethernet data services.
BASE PHONE	Connect your existing phone to the SuperLine Adapter. This jack provides uninterrupted phone service in the event of a power outage.
LINE	Connect your SuperLine Adapter to the existing phone's wall jack.

Installing Your SuperLine Adapter

There are several ways to connect your SuperLine Adapter, depending on your current phone configuration, data needs (Internet), and future needs. You can connect any combination of two phones, fax machines, or modems through your adapter. Any device connected to your adapter must be FCC Part 68-registered for the U.S. and Industry Canada CS-03-certified for use in Canada.

- **Connecting Multiple Phones, Fax Machines, or Modems to Your Adapter**
This procedure describes how to connect multiple phones, fax machines, or modems to your SuperLine Adapter (page 10).
- **Connecting a 2-Line Phone (with One or Two Superlines)**
This procedure describes how to connect a 2-line phone to your SuperLine Adapter if you have purchased one or two superlines with your adapter (page 12).
- **Connecting 2-Line Phone (with Two Superlines)**
This procedure describes how to connect a 2-line phone to your SuperLine Adapter if you have purchased two superlines with your adapter (page 14). You can also connect the third line of a 3-line phone or an additional phone, fax machine, or modem.
- **Connecting a Modem to Your Adapter**
This procedure describes how to connect a modem through the superline PHONE 1/2 and PHONE 2 jacks on your adapter rear panel (page 16).
- **Optional Configuration**
This procedure describes how to connect multiple phones, fax machines, or modems in separate rooms (page 18). This configuration may not be applicable in all homes or small offices.
- **High-Speed Data Service**
This procedure describes how to connect your SuperLine Adapter to a PC or Hub for high-speed Internet services (page 20). This feature may not be available in your area. Contact your local phone company for further information.
- **Connecting Phone Filters to Your Existing Phones**
This procedure describes how to connect a phone filter to your existing phones (page 21).
- **Applying Power to the Unit**
This section provides steps to apply power to your adapter and verify its proper operation (page 22).

Connecting Multiple Phones, Fax Machines, or Modems to Your Adapter

Hardware Required (Supplied)

- 6-foot RJ11 phone cable.

Hardware Required (Not Supplied)

- An RJ11 phone cable for each device you attach to the SuperLine Adapter.

► Procedure

Use the following procedure and supporting figure to connect your SuperLine Adapter with up to two additional phones, fax machines, or modems in the same room.

Existing Phone Line

- ❶ Plug one end of the 6-foot phone cable into the LINE jack on the adapter rear panel.
- ❷ Connect the other end of the cable into the wall jack.
- ❸ Connect your existing phone into the BASE PHONE jack on the adapter rear panel.

NOTE:

If you lose power to your SuperLine Adapter, the phone connected to the BASE PHONE jack, and other phones connected to the same line as the SuperLine Adapter, will still be operational.

Second Phone, Fax Machine, or Modem:

- ❹ Connect a second phone, fax machine, or modem into the PHONE 1/2 jack on the adapter rear panel.

NOTE:

If you use the PHONE 2 jack, do not use a 4-wire phone cable to connect phones, fax machines, or modems to the PHONE 1/2 jack. A 4-wire phone cable connected to the PHONE 1/2 jack may cause interference on phones, fax machines, or modems connected to the PHONE 2 jack.

Third Phone, Fax Machine, or Modem:

- ❺ Connect a third phone, fax machine, or modem into the PHONE 2 jack on the adapter rear panel.

To complete your SuperLine Adapter installation, refer to *Connecting Phone Filters to Your Existing Phones* on page 21, and *Applying Power to the Unit* on page 22.

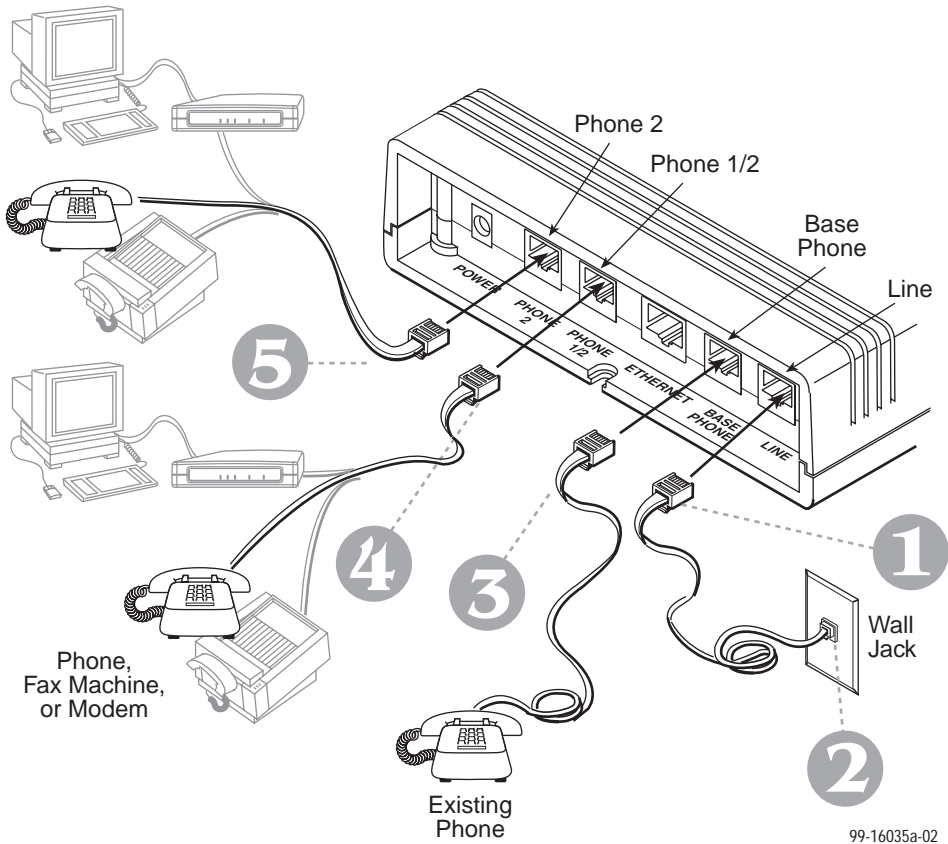

Connecting Multiple Phones, Fax Machines, or Modems to Your Adapter

CAUTION:

Do not attempt to connect phone cables from the PHONE 1/2 and PHONE 2 jacks to phones located outdoors. Keep all wiring connected to the PHONE 1/2 and PHONE 2 jacks within your home or office.

Connecting a 2-Line Phone (with Existing Phone and One or Two Superlines)

Hardware Required (Supplied)

- 6-foot RJ11 phone cable.

Hardware Required (Not Supplied)

- Two additional RJ11 phone cables to connect Lines 1 and 2 of your 2-line phone to your adapter.

► Procedure

Use the following procedure and supporting figure to connect your SuperLine Adapter to a single phone with two lines. This configuration can be used if you have one or two additional phone lines through your SuperLine Adapter.

Line 1:

- ❶ Plug one end of the 6-foot phone cable into the LINE jack on the adapter rear panel.
- ❷ Insert the other end of the phone cable into the wall jack.
- ❸ Connect Line 1 of your 2-line phone into the BASE PHONE jack on the adapter rear panel.

Line 2:

- ❹ Connect Line 2 of the 2-line phone into the PHONE 1/2 jack on the rear of the adapter.

NOTE:

If you use the PHONE 2 jack, do not use a 4-wire phone cable to connect phones, fax machines, or modems to the PHONE 1/2 jack. A 4-wire phone cable connected to the PHONE 1/2 jack may cause interference on phones, fax machines, or modems connected to the PHONE 2 jack.

Second Phone, Fax Machine, Modem, or Line 3:

- ❺ If you have purchased two superlines, you can connect a second phone, fax machine, modem, or Line 3 of a 3-line phone into the PHONE 2 jack on the adapter rear panel.

To complete your SuperLine Adapter installation, refer to *Connecting Phone Filters to Your Existing Phones* on page 21, and *Applying Power to the Unit* on page 22.

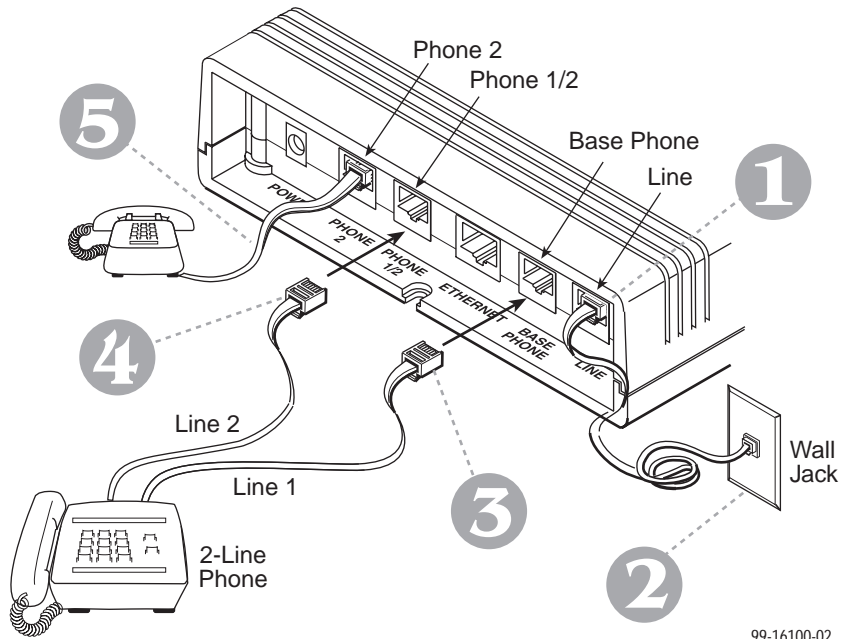

99-16100-02

Connecting a 2-Line Phone (with One or Two Superlines)

CAUTION:

Do not attempt to connect phone cables from the PHONE 1/2 and PHONE 2 jacks to phones located outdoors. Keep all wiring connected to the PHONE 1/2 and PHONE 2 jacks within your home or office.

Connecting a 2-Line Phone (with Two Superlines)

Hardware Required (Supplied)

- 6-foot RJ11 phone cable.

Hardware Required (Not Supplied)

- A 2-line phone cable (RJ14C) to connect Lines 1 and 2 of your 2-line phone to your SuperLine Adapter. Refer to *Technical Information* on page 23 for RJ14C phone cable pin configuration.

► Procedure

Use the following procedure and supporting figure to connect your SuperLine Adapter to a single phone with two lines.

NOTE:

Use this configuration only if you have two additional phone lines through your SuperLine Adapter.

Lines 1 and 2:

- ❶ Plug one end of the 6-foot phone cable into the LINE jack on the adapter rear panel.
- ❷ Insert the other end of the cable into the wall jack.
- ❸ Connect your 2-line phone using the 2-line RJ14C phone cable to the PHONE 1/2 jack on the adapter rear panel. The 2-line phone cable connects both lines through the PHONE 1/2 jack.

NOTE:

The PHONE 2 jack cannot be used to connect additional phones, fax machines, or modems in this configuration.

Existing Phone, Fax Machine, or Modem:

- ❹ Connect your existing phone, fax machine, or modem to the BASE PHONE jack on the adapter rear panel.

NOTE:

If you lose power to your SuperLine Adapter, the phone connected to the BASE PHONE jack will still be operational.

To complete your SuperLine Adapter installation, refer to *Connecting Phone Filters to Your Existing Phones* on page 21, and *Applying Power to the Unit* on page 22.

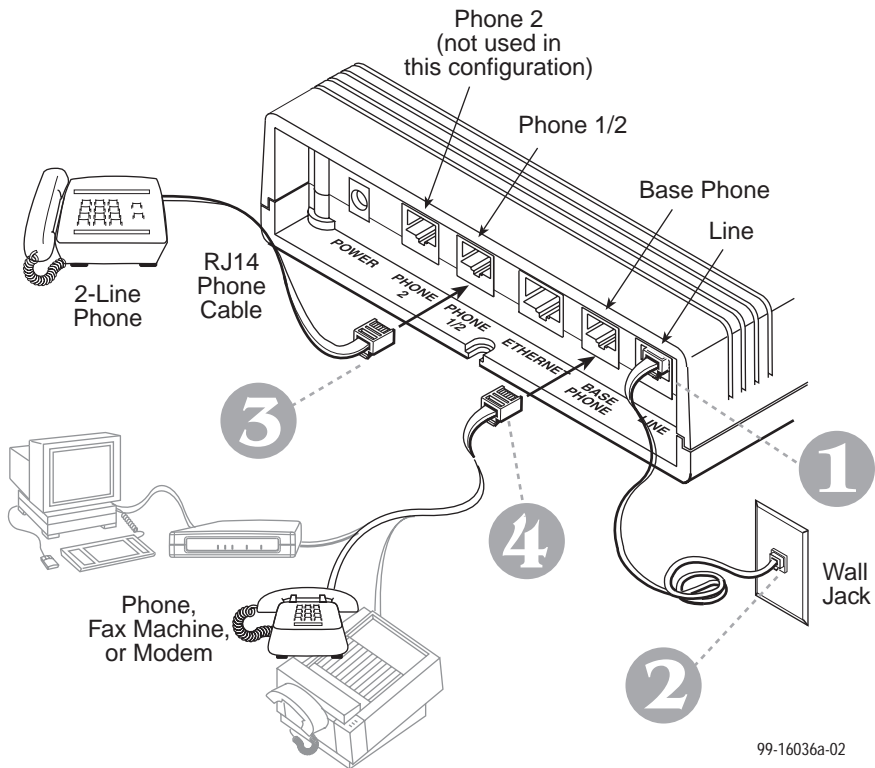

Connecting a 2-Line Phone (with Two Superlines)

CAUTION:

Do not attempt to connect phone cables from the PHONE 1/2 and PHONE 2 jacks to phones located outdoors. Keep all wiring connected to the PHONE 1/2 and PHONE 2 jacks within your home or office.

Connecting a Modem to Your Adapter

Hardware Required (Not Supplied)

- An RJ11 phone cable to connect your modem.

► Procedure

Use the following procedure and supporting figure to connect a modem to your SuperLine Adapter.

NOTE:

Any modem can be connected to the PHONE 1, PHONE 2 or BASE PHONE jacks of your adapter. However, if you have an International Telecommunications Union (ITU) V.90 standard 56 kbps modem connected to the PHONE 1/2 or PHONE 2 jacks, your SuperLine Adapter allows you to achieve True56K upload and download speeds.

Modem Connection:

- ① Connect the output of your modem to the PHONE 1/2 or PHONE 2 jack on the adapter rear panel.
 - Use only the PHONE 1/2 jack if you have one additional phone line added.
 - Use either the PHONE 1/2 or PHONE 2 jack if you have two additional phone lines added. You can connect an additional phone, fax machine, or another modem to the unused jack (PHONE 1/2 or PHONE 2).

To complete your SuperLine Adapter installation, refer to *Connecting Phone Filters to Your Existing Phones* on page 21, and *Applying Power to the Unit* on page 22.

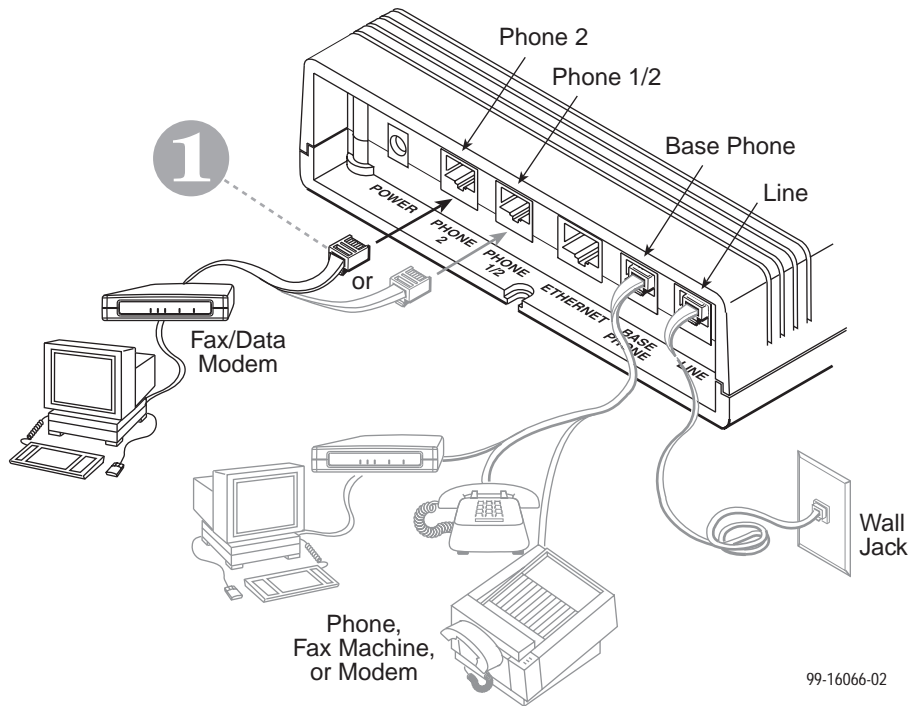

99-16066-02

Connecting a Modem

Optional Configuration

If your home or office phone jacks are wired internally with 4 wires (Pins 2, 3, 4, and 5), you may be able to connect phones in other rooms to your SuperLine Adapter by using optional hardware purchased from your local electronics or phone store. If you are unsure if your home or office is wired with 4 wires, contact an electrician or your local phone company.

Hardware Required (Supplied)

- 6-foot RJ11 phone cable.

Hardware Required (Not Supplied)

- "T" type connectors. Refer to *Technical Information* on page 25 for "T" type connector specifications.
- Second RJ11 phone cable.

► Procedure

Use the following procedure and supporting figure to install your SuperLine Adapter with multiple phones, fax machines, or modems connected in other rooms.

In the Same Room as Your Adapter:

- ❶ Plug a "T" type connector into the wall jack of the room where the adapter is located.
- ❷ Plug one end of the phone cable into the LINE jack on the adapter rear panel.
- ❸ Plug the other end of the phone cable into Line 1 of the "T" type connector.
- ❹ Plug a second phone cable (not supplied) to Line 2 of the "T" type connector.
- ❺ Plug the other end of the second phone cable into the PHONE 1/2 jack on the adapter rear panel.

NOTE:

Do not use a 4-wire phone cable to connect phones, fax machines, or modems to the PHONE 1/2 jack. A 4-wire phone cable connected to the PHONE 1/2 jack may cause interference on devices connected to the PHONE 2 jack.

In Another Room:

- ❻ Plug a second "T" type connector into the wall jack of another room.
- ❼ Connect the additional phone to Line 2 of the "T" type connector. You can connect a phone to your existing phone line using Line 1 of the "T" type connector and a phone filter as shown.
- ❽ Repeat Steps 6 and 7 for any additional rooms you want to connect.

Third Phone, Fax or Modem:

- ❾ If applicable, connect a third phone, fax machine, or modem into the PHONE 2 jack on the adapter rear panel.

To complete your SuperLine Adapter installation, refer to *Connecting Phone Filters to Your Existing Phones* on page 21, and *Applying Power to the Unit* on page 22.

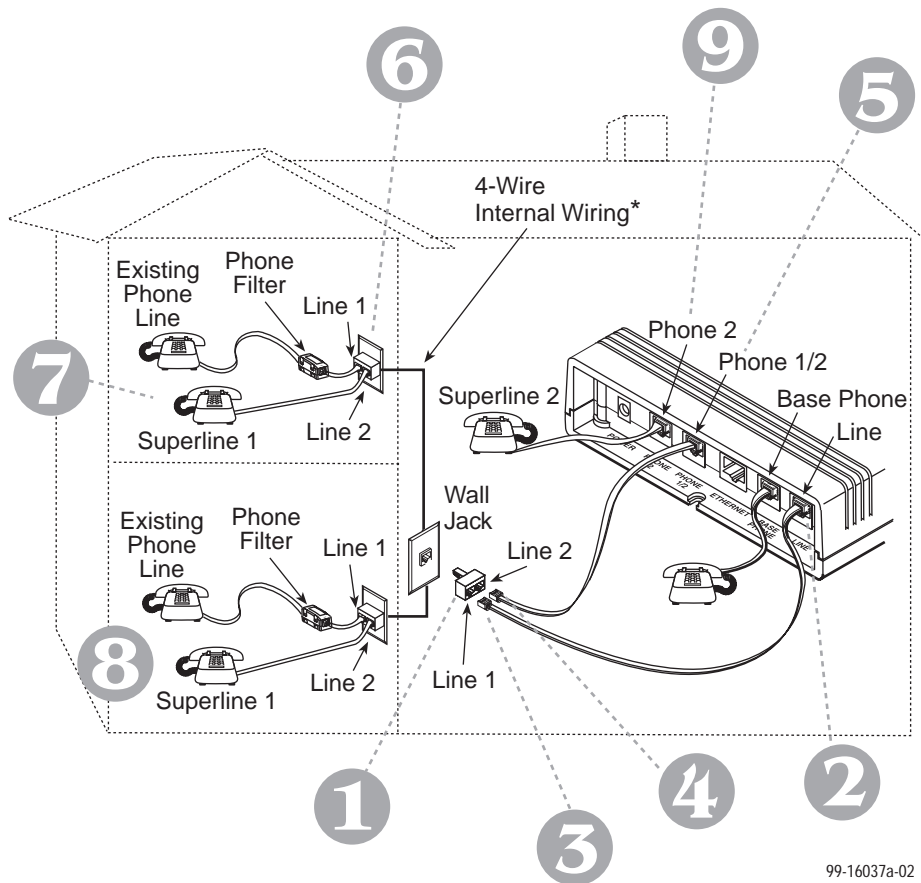

99-16037a-02

* Not all homes or offices are wired internally with 4 wires. If you are unsure of your internal home or office wiring, contact your local phone company or an electrician.

Optional Configuration

CAUTION:

Do not attempt to connect phone cables from the PHONE 1/2 and PHONE 2 jacks to phones located outdoors. Keep all wiring connected to the PHONE 1/2 and PHONE 2 jacks within your home or office.

High-Speed Data Service (Not Available in all Areas)

The SuperLine Adapter allows you to connect to a PC network interface card (NIC) or Hub for high-speed Internet access. Contact your local phone company to determine if these services are available in your area.

Hardware Required (Not Supplied)

- Straight-through or crossover Ethernet interface cable. Refer to *Technical Information* on page 25 for Ethernet cable pin configurations.

► Procedure

Use the following procedure to connect your SuperLine Adapter to a PC or Hub.

Ethernet Connection:

- ➊ Plug one end of the cable into the ETHERNET jack on the adapter rear panel.
 - Use an 8-pin Ethernet crossover cable to connect your PC.
 - Use an 8-pin straight-through cable to connect to a Hub.
- ➋ Plug the other end into your PC network interface card (NIC) or Hub.

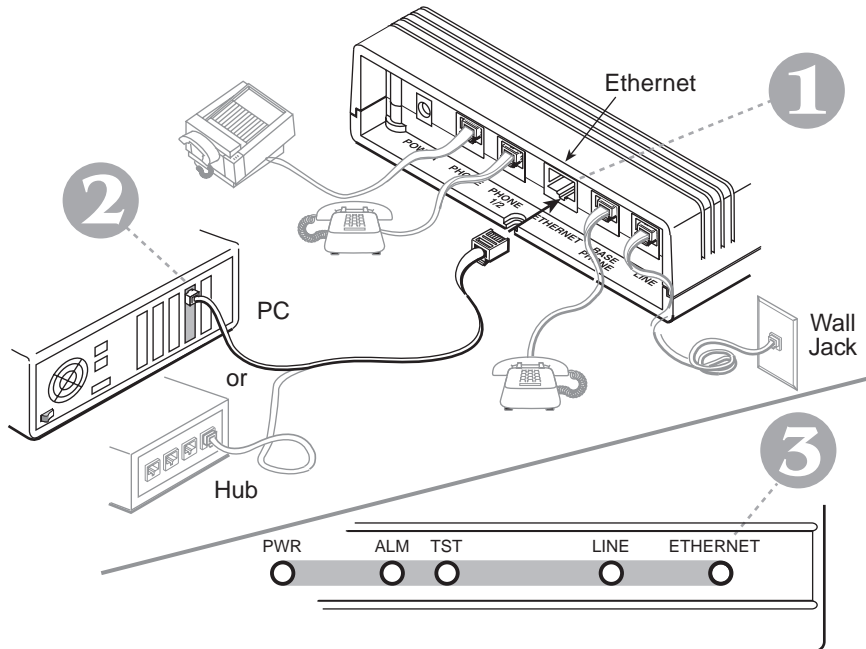

99-16038a-02

- ➌ Apply power to the unit (refer to *Applying Power to the Unit* on page 22). Verify the ETHERNET indicator on the adapter front panel is lit.

NOTE:

Your PC must be on in order for the ETHERNET indicator to light.

Connecting Phone Filters to Your Existing Phones

► Procedure

After you have installed your SuperLine Adapter, each phone in your home or office that is connected to the same line as the SuperLine Adapter must be connected through a phone filter to minimize background noise during telephone conversations. Use the following procedure to install phone filters on your existing phones.

NOTE:

You may need to purchase additional phone filters from your local telephone company.

- ❶ Disconnect the phone cord of your existing phone from the wall jack.
- ❷ Plug the phone cord into the PHONE jack on the phone filter.
- ❸ Plug the phone filter into the wall jack.

Repeat Steps 1–3 for each phone in your home or office that is not connected through your SuperLine Adapter.

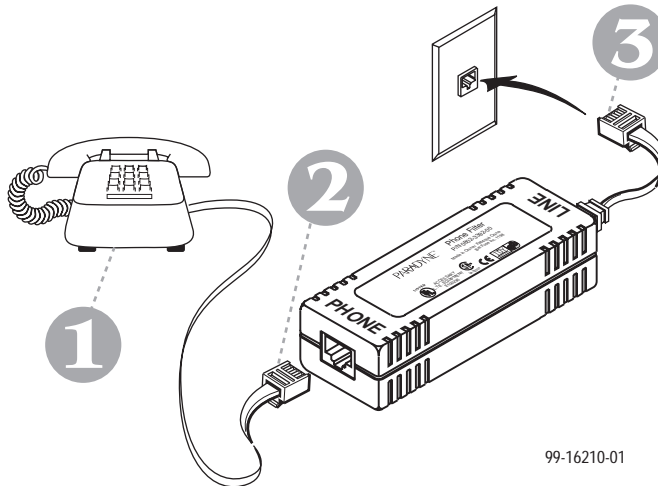

99-16210-01

Applying Power to the Unit

► Procedure

After you have installed your SuperLine Adapter, use the following procedure to apply power to the adapter.

- ❶ Insert the power cord's cylindrical plug into the jack labeled POWER on the adapter rear panel.
- ❷ Plug the transformer into an AC power outlet.

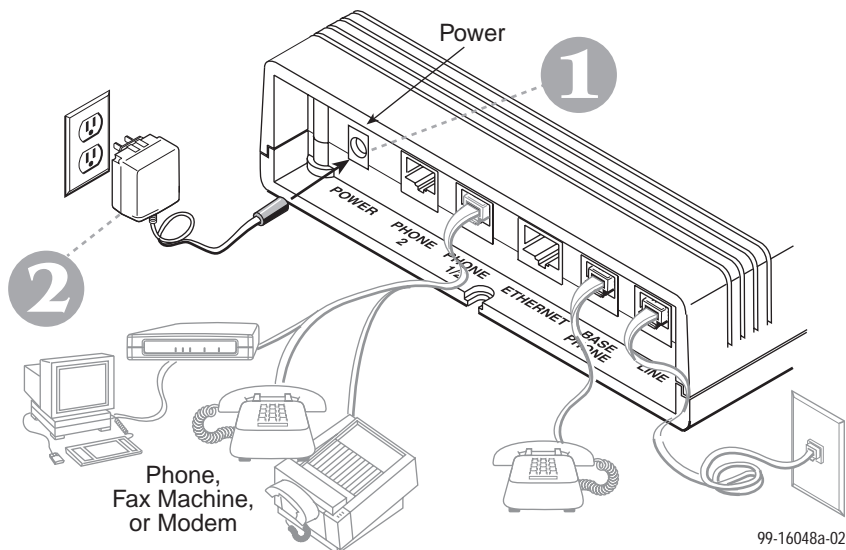

After power is applied, the adapter performs a power-on self-test. During the power-on self-test, all front panel indicators light for one second and then turn off. Only the PWR, LINE, and ETHERNET (if applicable) indicators remain lit. If any other indicators remain lit, refer to *Troubleshooting Your Adapter* on page 23. Refer to *Front Panel Indicators* on page 7 for more information on SuperLine Adapter front panel indicators.

Congratulations, your SuperLine Adapter installation is now complete.

Troubleshooting Your Adapter

Symptom	Action
All indicators remain ON.	The adapter is not functional. If the indicators remain ON after five minutes, contact your customer support center. Refer to <i>Technical Support</i> on page 28.
ALM indicator remains ON. (PWR will be ON and ETHERNET may be ON.)	The power-on self-test has failed. Unplug the unit and reapply power. If the alarm indicator remains ON, contact your customer support center. Refer to <i>Technical Support</i> on page 28. Also see the entry for <i>ALM and TST indicators remain ON</i> .
TST indicator remains ON. (PWR will be ON and LINE and ETHERNET may be ON.)	This indicator may be on in conjunction with the ALM indicator. Also see the entry for <i>ALM and TST indicators remain ON</i> . If the TST indicator remains ON and the ALM indicator is OFF and superline service is not available, contact your customer support center. Refer to <i>Technical Support</i> on page 28.
ALM and TST indicators remain ON. (PWR will be ON and LINE and ETHERNET may be ON.)	Your Network Service Provider has initiated a test or upgrade of your adapter. This operation may be performed periodically to ensure your adapter operates to its full potential. The duration of this condition may vary and persist for a few minutes. During this time your conventional phone will continue to operate. However, superline services will not be available. If this condition continues for a significantly longer time (30 minutes) contact your customer support center. Refer to <i>Technical Support</i> on page 28.
ETHERNET indicator is OFF. (PWR will be ON and LINE may be ON.)	Verify that the Ethernet 10BaseT cable is securely installed at both ends, and at least one PC is connected and powered on.
	Verify that the correct straight-through or crossover cable is installed. Refer to <i>High-Speed Data Service</i> on page 20.
LINE indicator is OFF. (PWR is ON.)	Verify that the phone cable connected to the LINE jack is securely installed at both ends. If problem continues, contact your customer support center. Refer to <i>Technical Support</i> on page 28.
	Verify that the superline has a dial tone. If there is no dial tone, contact your customer support center. Refer to <i>Technical Support</i> on page 28.
LINE indicator is ON and there is no dial tone on your superline phones. (PWR will be ON and LINE and ETHERNET may be ON.)	The link has been established but there is no data transmission. If the problem persists, contact your network service provider. Refer to <i>Technical Support</i> on page 28.

Symptom	Action
PWR indicator is OFF.	Check that the power cord is securely installed on both ends.
	If no other indicators are on, the power supply may be defective. Plug the adapter into another outlet. If the problem persists, contact the customer support center. Refer to <i>Technical Support</i> on page 28.
	If other indicators are on, the PWR indicator may not be operational. Unplug the unit and reapply power; watch all indicators during the power-on self-test to verify if the PWR indicator is operational.
Your superline phone does not ring but you can place calls.	Verify the total Ringer Equivalency Number (REN) of all of the phones connected to your PHONE 1/2 or PHONE 2 jack does not exceed 3.
There is no dial tone at the PHONE 2 jack.	Verify that your telephone company has supplied you with two superlines.
You detect distortion on the phone connected to the PHONE 1/2 or PHONE 2 jack.	If you use the PHONE 2 jack, verify that you are not using a 4-wire phone cable for the device connected to the PHONE 1/2 jack.
	Verify that you used the supplied 6-foot cable to connect the LINE jack of the SuperLine Adapter to the wall outlet.
The modem or fax machine connected to the PHONE 1/2 or PHONE 2 jack does not work properly.	If you use the PHONE 2 jack, verify that you are not using a 4-wire phone cable for the device connected to the PHONE 1/2 jack.
	Verify that you used the supplied 6-foot cable to connect the LINE jack of the SuperLine Adapter to the wall outlet.

Technical Information

This section contains reference information.

Phone Filter

Phone filters are required to minimize audible background noise that occurs with your existing telephones during phone conversations on phones not connected through your SuperLine Adapter.

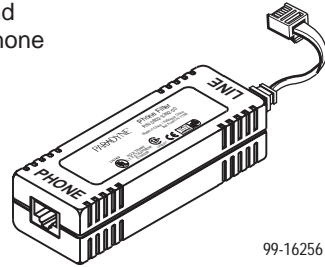

99-16256

RJ11 or RJ14C Phone Cables

- All standard phones, fax machines, and modems that connect to your adapter use a 6-pin, non-keyed modular plug (RJ11 or RJ14C).

RJ11 6-Pin Connector

Pin #	Function
1	Not used
2	Not used
3	Ring
4	Tip
5	Not used
6	Not used

RJ14C 6-Pin Connector

Pin #	Function
1	Not used
2	Ring (Line 2)
3	Ring (Line 1)
4	Tip (Line 1)
5	Tip (Line 2)
6	Not used

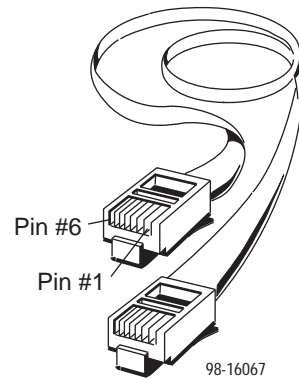

98-16067

Ethernet Cable

The Ethernet interface connector uses an 8-pin, non-keyed modular plug.

- Use the straight-through connection to connect to an Ethernet Hub. 24 AWG, Cat 5 cable is recommended.

8-Pin Straight-Through Connection

Pin #	Function
1	10BaseT TX D+
2	10BaseT TX D-
3	10BaseT RX D+
4 & 5	Not used
6	10BaseT RX D-
7 & 8	Not used

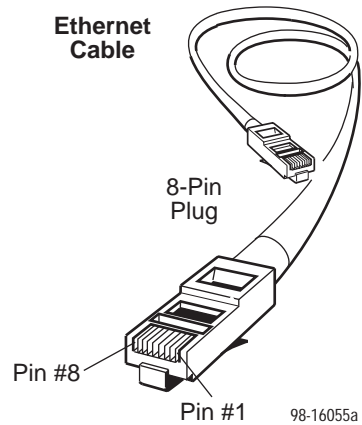

- Use an Ethernet crossover cable to connect your adapter directly to a PC with an Ethernet network interface card. 24 AWG, Cat 5 cable is recommended.

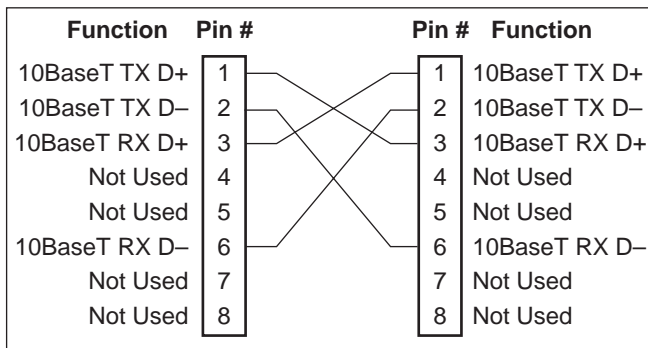

98-16056

“T” Type Connector

The “T” adapter allows additional phones to be connected to your SuperLine Adapter from other rooms. If your home or office internal phone wiring uses 4 wires connected to Pins 2, 3, 4, and 5, the “T” adapter crosses the normally unused Pins 2 and 5 to Pins 3 and 4 on Line 2 of the adapter. Connecting your SuperLine Adapter to Line 2 on the “T” connector creates an electrical connection to any room with a wall jack by using a second “T” connector and connecting the phone in that room to Line 2 of the second “T” connector.

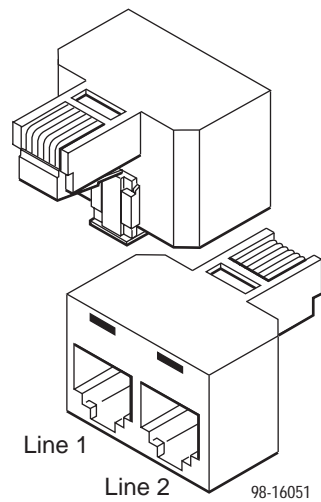
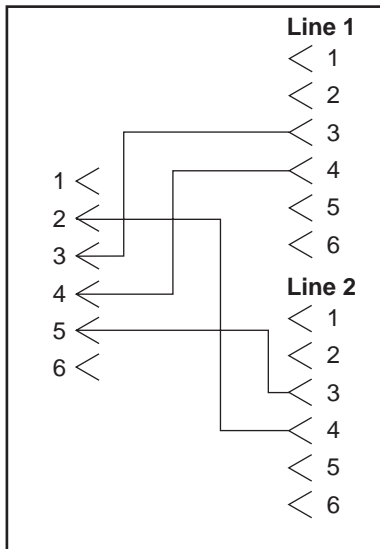

Technical Specifications

Item	Specification*
Height x Width x Depth	2.19" x 7.60" x 12.132" (5.56 cm x 19.30 cm x 30.82 cm)
Weight	2 lb. 2 oz.
Power Class 2 Transformer normal service input voltage range	Input: 120 Vac ($\pm 10\%$), 60 Hz Output: 18 Vdc nominal at 0.6A
Approvals FCC Part 15 Safety Certifications	Class B digital device Refer to equipment's label for approvals on product.
Physical Environment Operating temperature Storage temperature Relative humidity Shock and vibration	32° F to 104° F (0° C to 40° C) -4° F to 158° F (-20° C to 70° C) 5% to 95% (noncondensing) Withstands normal shipping and handling
Heat Dissipation	22.2 Btu/hr. (max.) at nominal input voltage
Interface Connectors Line and Phone Interfaces Ethernet Type II Frame	RJ11/RJ14 6-pin 10BaseT 8-pin
REN Support	Provides adequate ringing signals for a total REN of 3 on each SuperLine port (PHONE 1/2 or PHONE 2)
* Technical Specifications subject to change without notification.	

Technical Support

For assistance installing or configuring your SuperLine Adapter, contact your local telephone company.

Trademarks

All products and services mentioned herein are the trademarks, service marks, registered trademarks or registered service marks of their respective owners.



6512-A2-GN10-20

Copyright © 1999 Paradyne Corporation