



## **AREA CODE CHANGE**

**Please note that the area code for Paradyne Corporation in Largo, Florida has changed from 813 to 727.**

**For any Paradyne telephone number that appears in this manual with an 813 area code, dial 727 instead.**



**HOTWIRE  
MODEL 7900 NEST  
AND OPTIONS  
INSTALLATION GUIDE**

**Document No. 7900-A2-GN20-10**

August 1997

---

**Copyright © 1997 Paradyne Corporation.**  
**All rights reserved.**  
**Printed in U.S.A.**

## **Notice**

This publication is protected by federal copyright law. No part of this publication may be copied or distributed, transmitted, transcribed, stored in a retrieval system, or translated into any human or computer language in any form or by any means, electronic, mechanical, magnetic, manual or otherwise, or disclosed to third parties without the express written permission of Paradyne Corporation, 8545 126th Avenue North, P.O. Box 2826, Largo, Florida 33779-2826.

Paradyne Corporation makes no representation or warranties with respect to the contents hereof and specifically disclaims any implied warranties of merchantability or fitness for a particular purpose. Further, Paradyne Corporation reserves the right to revise this publication and to make changes from time to time in the contents hereof without obligation of Paradyne Corporation to notify any person of such revision or changes.

Changes and enhancements to the product and to the information herein will be documented and issued as a new release to this manual.

## **Trademarks**

All products and services mentioned herein are the trademarks, service marks, registered trademarks or registered service marks of their respective owners.

## **Warranty, Sales, and Service Information**

Contact your sales or service representative directly for any help needed. For additional information concerning warranty, sales, service, repair, installation, documentation, or training, use one of the following methods:

- **Via the Internet:** Visit the Paradyne World Wide Web site at <http://www.paradyne.com>
- **Via Telephone:** Call our automated call system to receive current information via fax or to speak with a company representative.
  - Within the U.S.A., call 1-800-870-2221
  - International, call 813-530-2340



Printed on recycled paper

## Important Safety Instructions

1. Read and follow all warning notices and instructions marked on the product or included in the manual.
2. This product is intended to be used with a 3-wire grounding type plug – a plug which has a grounding pin. This is a safety feature. Equipment grounding is vital to ensure safe operation. Do not defeat the purpose of the grounding type plug by modifying the plug or using an adapter.  

Prior to installation, use an outlet tester or a voltmeter to check the ac receptacle for the presence of earth ground. If the receptacle is not properly grounded, the installation must not continue until a qualified electrician has corrected the problem.

If a 3-wire grounding type power source is not available, consult a qualified electrician to determine another method of grounding the equipment.

The dc configuration of this product is to be grounded by connecting an external wire between the building ground and the equipment ground screw on the rear of the power supply assembly. Consult a qualified electrician to ensure that the ground connections are connected.
3. Slots and openings in the cabinet are provided for ventilation. To ensure reliable operation of the product and to protect it from overheating, these slots and openings must not be blocked or covered.
4. Do not allow anything to rest on the power cord and do not locate the product where persons will walk on the power cord.
5. Do not attempt to service this product yourself, as opening or removing covers may expose you to dangerous high voltage points or other risks. Refer all servicing to qualified service personnel.
6. General purpose cables are provided with this product. Special cables, which may be required by the regulatory inspection authority for the installation site, are the responsibility of the customer.
7. When installed in the final configuration, the product must comply with the applicable Safety Standards and regulatory requirements of the country in which it is installed. If necessary, consult with the appropriate regulatory agencies and inspection authorities to ensure compliance.
8. A rare phenomenon can create a voltage potential between the earth grounds of two or more buildings. If products installed in separate buildings are **interconnected**, the voltage potential may cause a hazardous condition. Consult a qualified electrical consultant to determine whether or not this phenomenon exists and, if necessary, implement corrective action prior to interconnecting the products.
9. In addition, if the equipment is to be used with telecommunications circuits, take the following precautions:
  - Never install telephone wiring during a lightning storm.
  - Never install telephone jacks in wet locations unless the jack is specifically designed for wet locations.
  - Never touch un-insulated telephone wires or terminals unless the telephone line has been disconnected at the network interface.
  - Use caution when installing or modifying telephone lines.
  - Avoid using a telephone (other than a cordless type) during an electrical storm. There may be a remote risk of electric shock from lightning.
  - Do not use the telephone to report a gas leak in the vicinity of the leak.

## EMI Warnings

### **⚠ WARNING:**

This equipment has been tested and found to comply with the limits for a Class A digital device, pursuant to Part 15 of the FCC rules. These limits are designed to provide reasonable protection against harmful interference when the equipment is operated in a commercial environment. This equipment generates, uses, and can radiate radio frequency energy and, if not installed and used in accordance with the instruction manual, may cause harmful interference to radio communications. Operation of this equipment in a residential area is likely to cause harmful interference in which case the user will be required to correct the interference at his own expense.

The authority to operate this equipment is conditioned by the requirements that no modifications will be made to the equipment unless the changes or modifications are expressly approved by Paradyne Corporation.

### **⚠ WARNING:**

Front Panel Fillers are required to be installed for EMI safety purposes. Install nest filler panels to cover all nest card slots that do not contain nest cards.

### **⚠ WARNING:**

To Users of Digital Apparatus in Canada:

This Class A digital apparatus meets all requirements of the Canadian interference-causing equipment regulations.

Cet appareil numérique de la classe A respecte toutes les exigences du règlement sur le matériel brouilleur du Canada.

---

# Contents

---

## About This Guide

- Document Purpose and Intended Audience ..... iii
- Document Summary ..... iii
- Product-Related Documents ..... iv

## 1 About the HotWire Model 7900 Nest

- Overview ..... 1-1
- Available Options ..... 1-2

## 2 Preparing for Installation

- Prepare the Site ..... 2-1
- Inspect the Shipping Container ..... 2-1
- Remove and Inspect the Equipment ..... 2-2
- Order of Installation ..... 2-2
- Required Tools ..... 2-2

## 3 Installing the HotWire 7900 Nest and Options

- Installing the Nest ..... 3-1
- HotWire Model 7900 Nest Rear Panel Connectors ..... 3-3
- Installing the Heat Deflector Module (Multiple Adjacent Nest Installations Only) ..... 3-4
- Cabling Procedures ..... 3-5
  - Connecting the Nest to the T1 or E1 Network ..... 3-5
  - Connecting the Nest to the DSL Local Loop ..... 3-7
- Connecting the Nest to Existing –48 Vdc Power ..... 3-8
- Installing the –48 Vdc Power Supply ..... 3-8
- Applying Power to the Nest ..... 3-10
- Installing Nest Card Termination Units ..... 3-10
- Installing Nest Filler Panels ..... 3-11

## **A Cables, Connectors, and Pin Assignments**

- T1/E1 Network Cable ..... A-1
- HDSL Local Loop Cable Pinouts ..... A-3
- SDSL Local Loop Cable Pinouts ..... A-6

## **Glossary**

## **Index**

---

# About This Guide

---

## Document Purpose and Intended Audience

This guide contains information needed to set up, configure, and install the HotWire Model 7900 16-Slot Nest.

It is expected that readers of this document are central-site technicians, special service installation technicians, or network engineers who have an understanding of digital subscriber line systems and Digital Subscriber Loop (DSL) transmission systems.

## Document Summary

Section	Description
Chapter 1	<i>About the HotWire Model 7900 Nest.</i> Describes the features of the HotWire Model 7900 Nest and shows typical configurations.
Chapter 2	<i>Preparing for Installation.</i> Describes the procedures taken prior to installing the nest.
Chapter 3	<i>Installing the HotWire 7900 Nest and Options.</i> Provides instructions for installing the nest, heat deflector module, –48 Vdc power supply, nest cards, and nest filler panels. This chapter also contains procedures for connecting network, and nest cables.
Appendix A	<i>Cables, Connectors, and Pin Assignments.</i> Contains connector pin assignment details.
Glossary	Defines the acronyms and terms used in this document.
Index	Lists the key terms, acronyms, and concepts, in alphabetical order.

## Product-Related Documents

<b>Document Number</b>	<b>Document Title</b>
7900-A2-GB20	<i>HotWire Model 7900 Basic Maintenance Processor User's Guide</i>
7900-A2-GB21	<i>HotWire Model 7900 SNMP Maintenance Processor User's Guide</i>
7910-A2-GB20	<i>HotWire Models 7914 and 7915 T1 &amp; E1 SDSL Nest Cards User's Guide</i>
7920-A2-GB20	<i>HotWire Models 7924 and 7925 T1 &amp; E1 HDSL Nest Cards User's Guide</i>
7924-A2-GB20	<i>HotWire Model 7924 Standalone T1 HSDL Termination Unit User's Guide</i>
7925-A2-GB20	<i>HotWire Model 7925 Standalone E1 HSDL Termination Unit User's Guide</i>

To order additional product documentation, refer to *Warranty, Sales, and Service Information* on page A at the beginning of this Installation Guide.

---

# About the HotWire Model 7900 Nest

# 1

---

## Overview

The HotWire Model 7900 Nest is designed for use in both commercial and central-site environments. The nest is a 19-inch wide rack that houses up to 16 nest card termination units. The number of nest cards in a nest depends on the type of configuration you choose.

The HotWire Model 7900 Nest:

- Mounts into a standard 19-inch equipment rack and can be adapted to mount into a 23-inch equipment rack
- Provides connections for dual (redundant) –48 Vdc power supplies
- Provides connections for T1 or E1 network and DSL local loop cables
- Provides connections to link up to three expansion nests to a primary nest with the maintenance processor option, HTU-M or HTU-S (SNMP compatible)

The optional HTU-M or HTU-S maintenance processors monitor status, store performance history, and display individual circuit and loop status for up to 62 (63 with an HTU-S) nest card termination units.

The HTU-S maintenance processor can interface with and report circuit status to your Network Management System using Simple Network Management Protocol (SNMP).

The following figure shows a fully loaded nest with the optional HotWire Model 7900 Basic Maintenance Processor (HTU-M) installed.

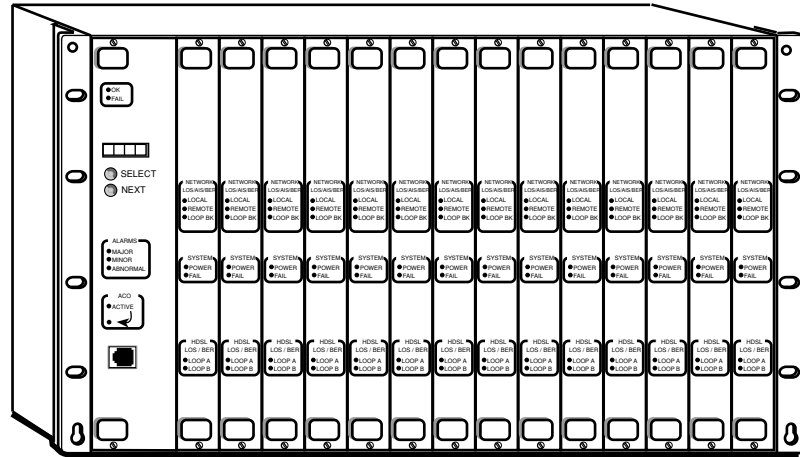

97-15408

**Fully Populated HotWire Model 7900 Nest**

## Available Options

The following options can be ordered separately:

- 7900-F1-300: HDSL Maintenance Processor (HTU-M)
- 7900-F1-310: HDSL Maintenance Processor (HTU-S) SNMP-Compatible
- 7900-F1-500: HDSL primary-to-expansion nest cable (36 inches/91 cm)
- 7900-F1-501: HDSL primary-to-expansion nest cable (56 inches/142 cm)
- 7900-F1-502: HDSL primary-to-expansion nest cable (78 inches/198 cm)
- 7900-F1-804: 19-inch Heat Deflector Module (for multiple nest configurations)
- 7900-F1-805: 19-inch to 23-inch nest adapter
- 7900-F1-810: HDSL and SDSL external power adapter 120 Vac to -48 Vdc North American-style plug
- 7900-F1-810: HDSL and SDSL external power adapter 230 Vac to -48 Vdc Euro-style plug

To order additional products, refer to *Warranty, Sales, and Service Information* on page A at the beginning of this Installation Guide.

---

# Preparing for Installation

# 2

---

## Prepare the Site

Before starting the installation, make sure you have:

- A dedicated, grounded ac outlet that is protected by a circuit breaker within 6 feet of the unit, or a dedicated –48 Vdc power source available.
- A clean, well-lit, and ventilated site that is free from environmental extremes.
- Sufficient clearance for cable connections.
- Contacted your network provider to coordinate installing the nest and its associated cards.

## Inspect the Shipping Container

Inspect the shipping container for signs of damage. Specific signs to check for are:

- Major tears or puncture holes on the sides of the container
- Splits in the seams
- Corner damage or any additional signs of the container having been dropped

If the shipping container shows signs of damage, report this immediately to your shipping or service representative.

## Remove and Inspect the Equipment

After unpacking your equipment, inspect the following units for damage:

- **Nest.** Remove the nest from its shipping container and check for physical damage.
- **Heat Deflector Module** (Multiple adjacent expansion nests only). Remove the module from its shipping container and check for physical damage. Ensure the module grounding cable is firmly attached to the module.
- **Power supply** (If optional power supply ordered). Ensure that the unit has not been damaged, possibly causing a short circuit of internal components.
- **Nest Cards.** Inspect each circuit card assembly for physical damage, bent connector pins, or missing jumpers (refer to *HotWire Models 7924 and 7925 T1 & E1 HDSL Nest Cards User's Guide* or *HotWire Models 7914 and 7915 T1 & E1 SDSL Nest Cards User's Guide* for the location of nest card jumpers).

## Order of Installation

Install the nest and its associated components in the following order:

1. Install the HotWire Model 7900 Nest in a standard equipment rack.
2. Install heat deflector module (for multiple adjacent expansion nest configurations).
3. Connect network and local loop cables.
4. Connect nest cables (for multiple expansion nest configurations with the maintenance processor option only).
5. Connect to existing –48 Vdc or install the –48 Vdc power supply.
6. Install nest cards.
7. Install nest card filler panels for slots without nest card termination units.

## Required Tools

Use the following tools to install the nest, heat deflector, power supply, nest cards, and nest filler panels:

- A large Phillips screwdriver to install the nest and heat deflector into the standard equipment rack.
- A small flat-blade screwdriver to install the power supply, tighten cable connector retaining screws, and tighten nest card and filler panel retaining screws.

---

# Installing the HotWire 7900 Nest and Options

# 3

---

## Installing the Nest

The HotWire Model 7900 Nest fits into a standard 19-inch wide equipment rack. See Figure 3-1.

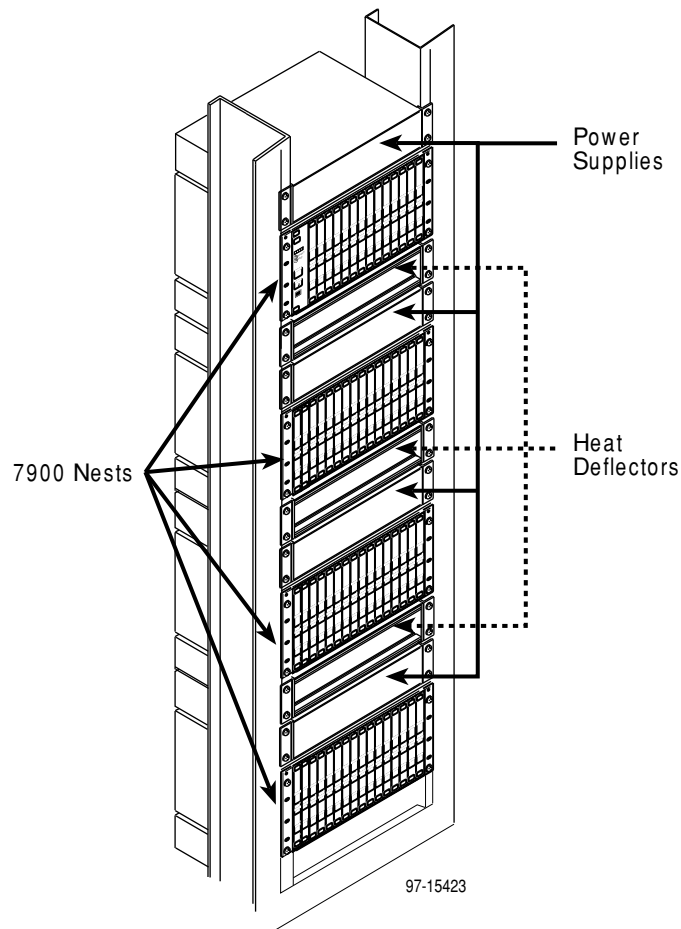

**Figure 3-1. Standard Equipment Rack with Fully Populated HotWire 7900 Nests, Heat Deflectors, and Power Supplies Installed**

**NOTE:**

A maximum of four HotWire 7900 Nests can be installed into one standard 72-inch equipment rack. When more than one nest is to be installed in the same equipment rack, start with the highest desired position in the rack and work downward. If you chose the maintenance processor option (HTU-M or HTU-S), the maintenance processor assembly is placed in the top nest and that nest is referred to as the primary nest.

► **Procedure**

To attach the HotWire 7900 Nest to the front of the standard equipment rack:

**NOTE:**

Speed nuts have been included to attach the nest to equipment racks that do not have threaded screw holes. If your equipment rack does not have threaded screw holes, position the nest in the cabinet to determine which front rail holes are used and slip a speed nut onto each front rail hole.

1. At the desired height, support the nest against the front rail of the equipment rack.
2. Align the nest's mounting bracket holes with the screw holes in the front rails of the equipment rack.

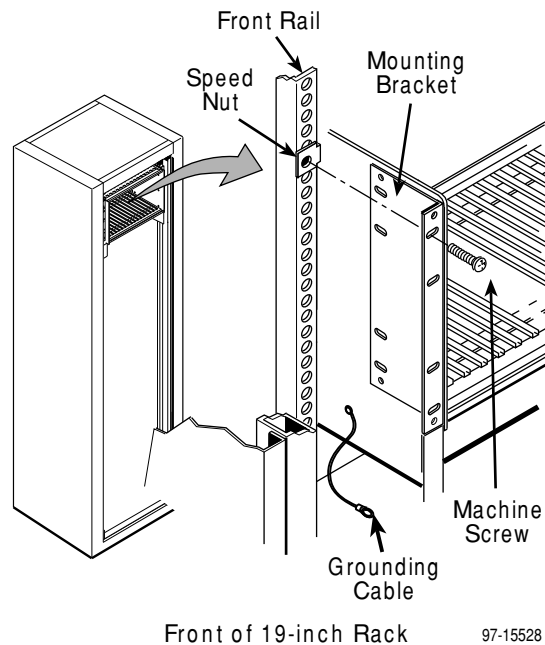

3. Attach the nest to the front rails of the equipment rack using four machine screws.
4. Connect the nest grounding cable to the equipment rack using a machine screw and lockwasher.
5. Tighten all four screws until the nest is securely mounted in the equipment rack.

6. If you are installing additional adjacent expansion nests:
  - Install the heat deflector module directly below the top nest using the *Installing the Heat Deflector Module* procedure. Refer to **Figure 3-1** for the location of the module.
  - Repeat Steps 1–5 to install the next nest (to a maximum of four nests, four power supplies, and three heat deflector modules) into the equipment rack.

## HotWire Model 7900 Nest Rear Panel Connectors

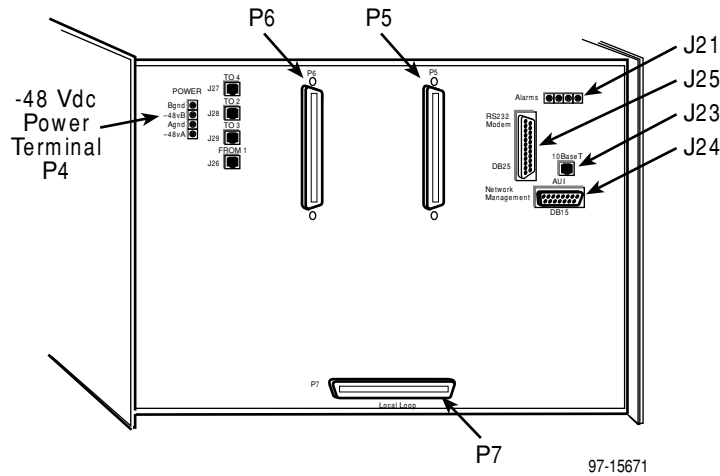

The following table lists the nest rear panel connectors:

Location	Connector	Function
P4	–48Vdc screw terminal	Allows you to connect –48 Vdc to the nest for distribution to the nest cards.
P5, P6	64-pin Champ connector	Provides connection to the T1 or E1 network.
P7	64-pin Champ connector	Provides connection to the DSL network.
J26–J29	Nest expansion connectors	Allows you to connect the primary nest (nest with maintenance processor option installed) to additional expansion nests (HTU-M or HTU-S maintenance processor options only).
J21	External alarm terminal	Allows you to connect external alarm circuits to the nest rear panel (HTU-M or HTU-S maintenance processor options only).
J23	10BaseT connector	Allows you to connect to a Network Management System using SNMP (HTU-S maintenance processor option only).
J24	DB15 connector	Allows you to connect to a Network Management System using SNMP (HTU-S maintenance processor option only).
J25	DB25 connector	Allows you to connect to a VT100 terminal (HTU-M or HTU-S maintenance processor options only).

## Installing the Heat Deflector Module (Multiple Adjacent Nest Installations Only)

A heat deflector module is installed below the nest to prevent heat generated from lower level nests and power supplies from rising to those above. Refer to [Figure 3-1](#) for the location of the heat deflector module in the equipment rack.

### NOTE:

This procedure assumes a fully populated rack as shown in [Figure 3-1](#) including four -48 Vdc power supplies and four expansion nests. If your configuration provides sufficient airflow between nests, you may not need to install heat deflector modules.

### ► Procedure

To install the heat deflector module:

### NOTE:

Speed nuts have been included to attach the heat deflector module to an equipment rack that does not have threaded screw holes. If your equipment rack does not have threaded screw holes, position the heat deflector in the cabinet to determine which front rail holes are used and slip a speed nut onto each rail hole.

1. Insert the heat deflector module directly below the highest nest in the equipment rack.
2. Align the heat deflector module's mounting bracket holes with the screw holes in the front rails of the equipment rack.

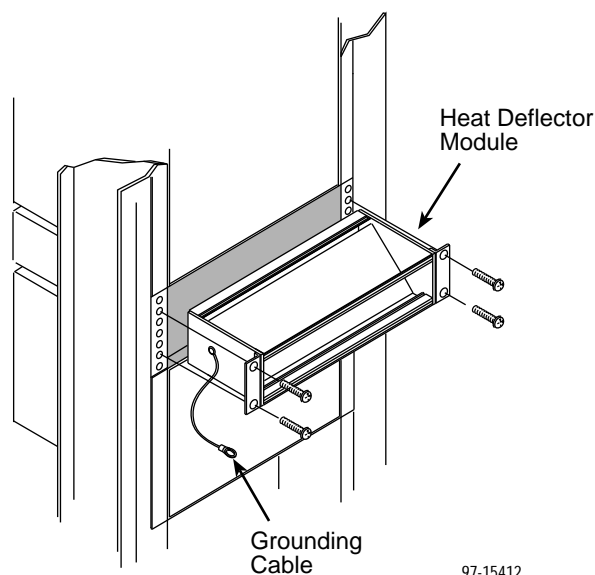

97-15412

3. Attach the module to the equipment rack using four machine screws.
4. Tighten all four screws until the heat deflector module is securely mounted to the equipment rack.
5. Connect the heat deflector module grounding cable to the equipment rack using a machine screw and a lockwasher.
6. Tighten the screw until the grounding cable is securely fastened to the rack.

## Cabling Procedures

There are five types of cable connections associated with the HotWire 7900 nest installation. These cable connections connect:

- The nest to the T1 or E1 Network
- The nest to the DSL local loop
- The primary nest to additional expansion nests (refer to *HotWire Model 7900 Basic Maintenance Processor User's Guide* or *HotWire Model 7900 SNMP Maintenance Processor User's Guide*)
- Major, minor, and abnormal alarms (refer to *HotWire Model 7900 Basic Maintenance Processor User's Guide* or *HotWire Model 7900 SNMP Maintenance Processor User's Guide*)
- A VT100-compatible terminal or terminal emulator (refer to *HotWire Model 7900 Basic Maintenance Processor User's Guide* or *HotWire Model 7900 SNMP Maintenance Processor User's Guide*)

### Connecting the Nest to the T1 or E1 Network

A single network cable can connect up to eight nest cards to a T1 or E1 network.

#### ► Procedure

To connect the nest to the T1 or E1 network:

1. Connect the 64-pin E1/T1 network cable Champ connector(s) to P5 or P6 on the nest rear panel.
  - If your nest will contain eight nest cards or fewer, connect the 64-pin Champ connector of the network cable to P5 on the nest rear panel.
  - If your nest will contain nine nest cards or more, connect the 64-pin Champ connector of one network cable to P5 and connect second network cable to P6.

2. Tighten the Champ connector retaining screw.

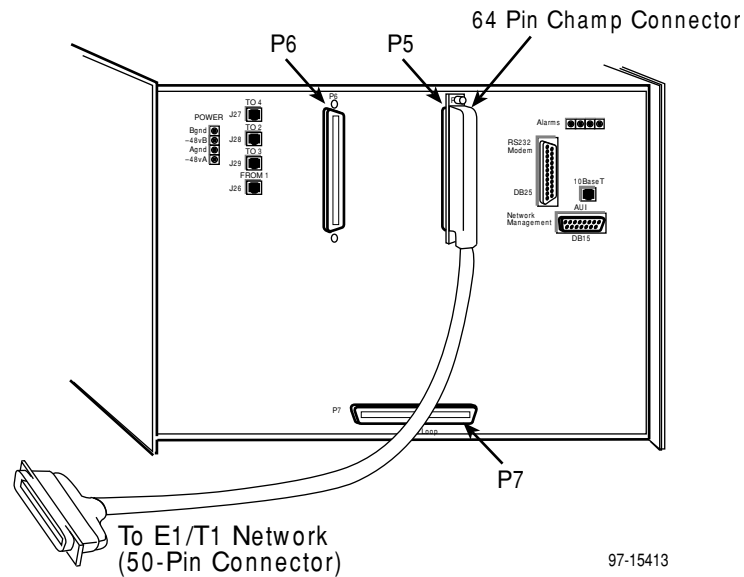

3. Connect the other end of the cable to the T1 or E1 network.

You can connect to the T1 or E1 network by:

- Using the 64-pin to 50-pin connector cable supplied with the nest.
- Removing the 50-pin connector and wiring to a standard punch-down block (refer to Appendix A, *Cables, Connectors, and Pin Assignments*, for cable pin assignments).
- Connecting the 50-pin connector to a 356A Type Modular RJ48 connector (com code 104 158 829). The 356A Modular RJ48 connector converts the 50-pin connector to eight RJ48 connector sockets. Each socket corresponds to one nest card termination unit.

## Connecting the Nest to the DSL Local Loop

The DSL local loop cable allows you to connect up to 16 nest card termination units to the DSL local loop.

### ► Procedure

To connect the nest to the DSL local loop:

1. Connect the 64-pin DSL local loop cable Champ connector to P7.
2. Tighten the cable connector retaining screw.

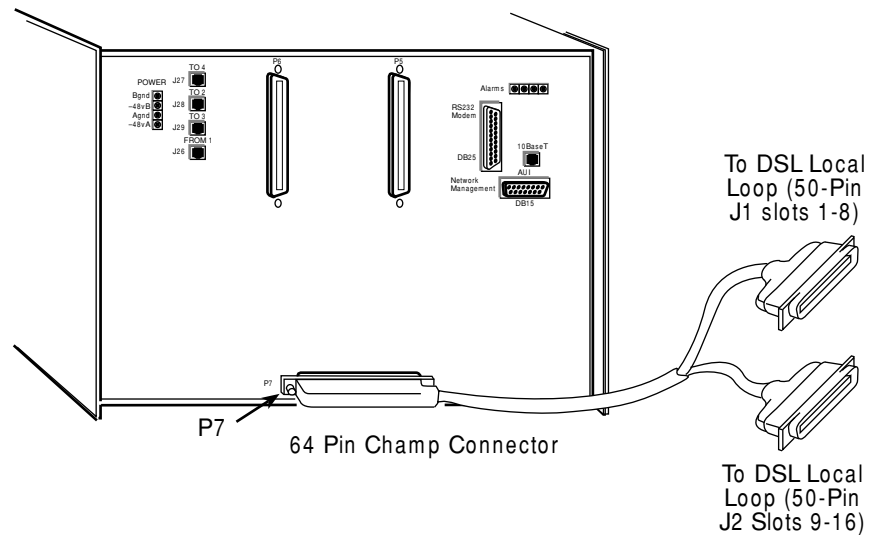

97-15415

3. Connect the other end of the cable to your DSL local loop.

You can connect to the DSL local loop by:

- Using the 64-pin to two 50-pin connector cable supplied with the nest.
- Removing the 50-pin connectors and wiring to a standard punch-down block (refer to Appendix A, *Cables, Connectors, and Pin Assignments*, for cable pin assignments).
- Connecting the 50-pin connector to a 356A Type Modular RJ48 connector (comcode 104 158 829). The 356A Modular RJ48 connector converts the 50-pin connector to eight RJ48 connector sockets. Each socket corresponds to one nest card termination unit.

## Connecting the Nest to Existing –48 Vdc Power

### ► Procedure

If –48 Vdc is available at your site:

1. Verify power is turned off at the circuit breaker or source.
2. Connect the –48 Vdc return line to the Agnd screw terminal on the nest rear panel.
3. Connect the –48 Vdc line to the –48vA screw terminal on the nest rear panel.  
Redundant –48 Vdc power can be connected to the Bgnd and –48vB screw terminals.

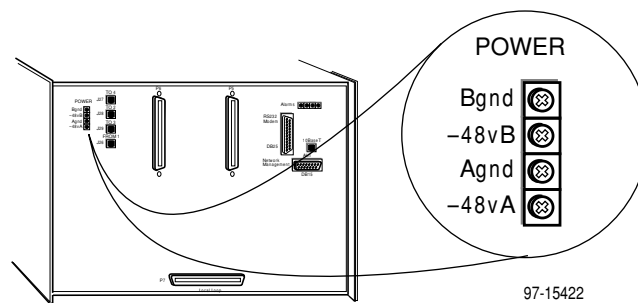

If –48 Vdc is not available at your site, see *Installing the –48 Vdc Power Supply*.

## Installing the –48 Vdc Power Supply

### ► Procedure

If –48 Vdc is not available at your site:

#### **NOTE:**

Speed nuts have been included to attach the power supply to an equipment rack that does not have threaded screw holes. If your equipment rack does not have threaded screw holes, position the power supply in the cabinet to determine which front rail holes are used and slip a speed nut onto each rail hole.

1. Refer to [Figure 3-1](#) for location of the –48 Vdc power supply within the rack.
2. Insert the –48 Vdc power supply into the equipment rack.
3. Align the power supply mounting bracket holes with the screw holes in the equipment rack.

4. Fasten the power supply to the equipment rack using four machine screws.

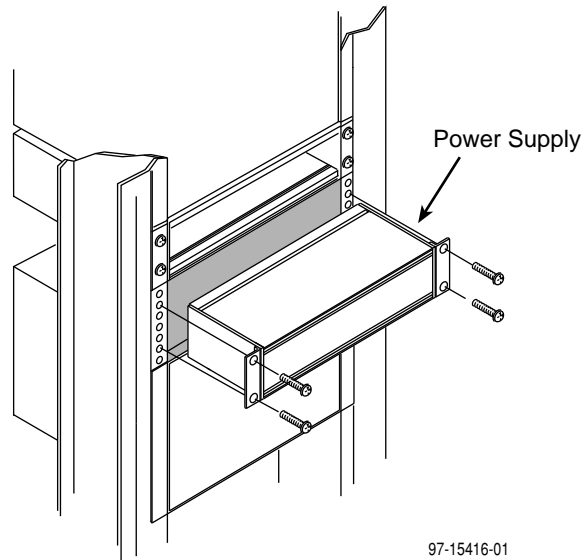

5. Tighten all four screws until the power supply is securely mounted to the equipment rack.
6. Connect the  $-48$  Vdc return line to the Agnd screw terminal on the nest rear panel.
7. Connect the  $-48$  Vdc line to the  $-48$ vA screw terminal on the nest rear panel.

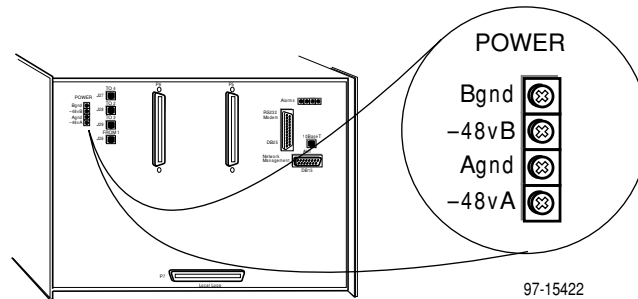

Repeat Steps 1–7 for each additional power supply.

Refer to the *Applying Power to the Nest* procedure prior to applying power to the nest.

## Applying Power to the Nest

If –48 Vdc is available at your site, apply power to the nest by turning on the circuit breaker or –48 Vdc source.

### CAUTION:

**The power supply power cord contains a 3-wire grounding-type plug which has a grounding pin. This is a safety feature. Grounding of the nest is vital to ensure safe operation. Do not defeat the purpose of the grounding plug by modifying it or by using a plug adapter.**

If –48 Vdc is not available at your site, plug the –48 Vdc power supply 3-pronged plug into an ac outlet.

## Installing Nest Card Termination Units

Use this procedure to install HotWire 7900 Nest Card Termination Units. Installation of the optional HotWire 7900 Maintenance Processor (HTU-M or HTU-S) is described in a separate user's guide. Refer to *Product-Related Documents* in *About This Guide*. Refer to the appropriate nest card user's guide to configure nest card termination units.

### ► Procedure

To install the nest card:

1. Use electrostatic discharge (ESD) protection when handling the electronic components. Remove the card from any protective packaging.

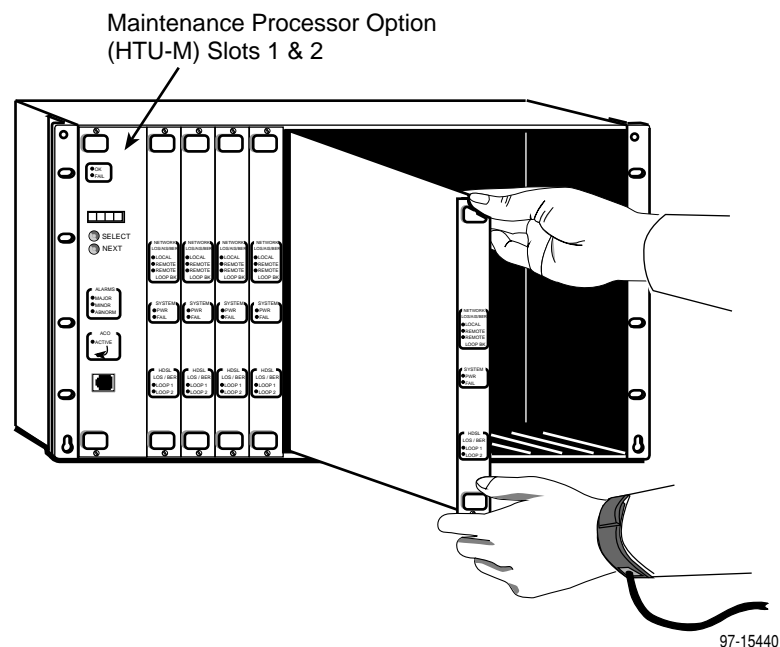

2. Align the circuit board with the top and bottom card guides of the next available card slot.
  - Slot 1 if no maintenance processor option is installed
  - Slot 2 if an HTU-S is installed in Slot 1
  - Slot 3 if an HTU-M is installed in Slots 1 and 2
3. Slide the nest card into the slot until the connector plug is seated firmly into the backplane.
4. Tighten retaining screws at the top and bottom of the nest card front panel.

## Installing Nest Filler Panels

Nest filler panels are required to be installed in slots that do not contain nest cards.

### **⚠ WARNING:**

**Front Panel Fillers are required to be installed for EMI safety purposes. Install nest filler panels to cover all nest card slots that do not contain nest cards.**

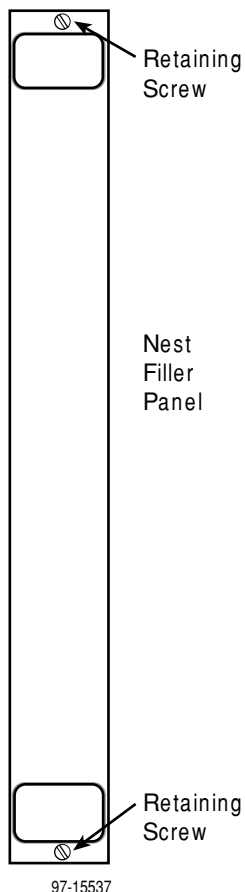

### **► Procedure**

To install nest filler panels:

1. Align the filler panel with the retaining screw holes located at the top and bottom of the nest.
2. Tighten filler panel retaining screws.
3. Repeat until all empty nest card slots are covered.

---

# Cables, Connectors, and Pin Assignments

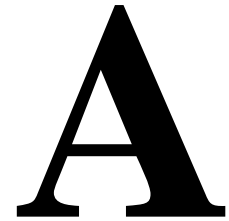

---

To order one of the following cables refer to *Warranty, Sales, and Service Information* on page A. Refer to Chapter 3, *Installing the HotWire 7900 Nest and Options*, for information on connecting these cables.

## T1/E1 Network Cable

**Slots 1–8 or 9–16 Digital T1/E1 Connector (P5 or P6)  
64-pin to 50-Pin Connector Conversion (1 of 3)**

Card Cage Slot	64-pin (P5 or P6) Connector Pin Number	50-pin Connector Pin Number	356-Type Modular RJ48 Adapter Pin Number	Function
Slot 1, 9	26	27	2	Tx to E1 or T1 Network – Tip
Slot 1, 9	25	2	1	Tx to E1 or T1 Network – Ring
Slot 1, 9	30	26	5	Rx from E1 or T1 Network – Tip
Slot 1, 9	29	1	4	Rx from E1 or T1 Network – Ring
Slot 2, 10	18	30	2	Tx to E1 or T1 Network – Tip
Slot 2, 10	17	5	1	Tx to E1 or T1 Network – Ring
Slot 2, 10	22	29	5	Rx from E1 or T1 Network – Tip
Slot 2, 10	21	4	4	Rx from E1 or T1 Network – Ring

**Slots 1–8 or 9–16 Digital T1/E1 Connector (P5 or P6)  
64-pin to 50-Pin Connector Conversion (2 of 3)**

<b>Card Cage Slot</b>	<b>64-pin (P5 or P6) Connector Pin Number</b>	<b>50-pin Connector Pin Number</b>	<b>356-Type Modular RJ48 Adapter Pin Number</b>	<b>Function</b>
Slot 3, 11	10	33	2	Tx to E1 or T1 Network – Tip
Slot 3, 11	9	8	1	Tx to E1 or T1 Network – Ring
Slot 3, 11	14	32	5	Rx from E1 or T1 Network – Tip
Slot 3, 11	13	7	4	Rx from E1 or T1 Network – Ring
Slot 4, 12	1	36	2	Tx to E1 or T1 Network – Tip
Slot 4, 12	2	11	1	Tx to E1 or T1 Network – Ring
Slot 4, 12	6	35	5	Rx from E1 or T1 Network – Tip
Slot 4, 12	5	10	4	Rx from E1 or T1 Network – Ring
Slot 5, 13	39	39	2	Tx to E1 or T1 Network – Tip
Slot 5, 13	40	14	1	Tx to E1 or T1 Network – Ring
Slot 5, 13	35	38	5	Rx from E1 or T1 Network – Tip
Slot 5, 13	36	13	4	Rx from E1 or T1 Network – Ring
Slot 6, 14	47	42	2	Tx to E1 or T1 Network – Tip
Slot 6, 14	48	17	1	Tx to E1 or T1 Network – Ring
Slot 6, 14	43	41	5	Rx from E1 or T1 Network – Tip
Slot 6, 14	44	16	4	Rx from E1 or T1 Network – Ring
Slot 7, 15	55	45	2	Tx to E1 or T1 Network – Tip
Slot 7, 15	56	20	1	Tx to E1 or T1 Network – Ring

**Slots 1–8 or 9–16 Digital T1/E1 Connector (P5 or P6)  
64-pin to 50-Pin Connector Conversion (3 of 3)**

Card Cage Slot	64-pin (P5 or P6) Connector Pin Number	50-pin Connector Pin Number	356-Type Modular RJ48 Adapter Pin Number	Function
Slot 7, 15	51	44	5	Rx from E1 or T1 Network – Tip
Slot 7, 15	52	19	4	Rx from E1 or T1 Network – Ring
Slot 8, 16	63	48	2	Tx to E1 or T1 Network – Tip
Slot 8, 16	64	23	1	Tx to E1 or T1 Network – Ring
Slot 8, 16	59	47	5	Rx from E1 or T1 Network – Tip
Slot 8, 16	60	22	4	Rx from E1 or T1 Network – Ring

## HDSL Local Loop Cable Pinouts

**Slot 1–16 Analog Connector (P7) 64-pin to two 50-Pin Connector Conversion (1 of 3)**

Card Cage Slot	64-pin (P7) Connector Pin Number	50-pin Connector Pin Number	356-Type Modular RJ48 Adapter Pin Number	Function
Slot 1	48	J1-27	1	Loop A – Tip
Slot 1	47	J1-2	2	Loop A – Ring
Slot 1	46	J1-28	3	Loop B – Tip
Slot 1	45	J1-1	4	Loop B – Ring
Slot 2	44	J1-30	1	Loop A – Tip
Slot 2	43	J1-5	2	Loop A – Ring
Slot 2	42	J1-31	3	Loop B – Tip
Slot 2	41	J1-4	4	Loop B – Ring
Slot 3	40	J1-33	1	Loop A – Tip
Slot 3	39	J1-8	2	Loop A – Ring

**Slot 1–16 Analog Connector (P7) 64-pin to  
two 50-Pin Connector Conversion (2 of 3)**

<b>Card Cage Slot</b>	<b>64-pin (P7) Connector Pin Number</b>	<b>50-pin Connector Pin Number</b>	<b>356-Type Modular RJ48 Adapter Pin Number</b>	<b>Function</b>
Slot 3	38	J1-34	3	Loop B – Tip
Slot 3	37	J1-7	4	Loop B – Ring
Slot 4	36	J1-36	1	Loop A – Tip
Slot 4	35	J1-11	2	Loop A – Ring
Slot 4	34	J1-37	3	Loop B – Tip
Slot 4	33	J1-10	4	Loop B – Ring
Slot 5	1	J1-39	1	Loop A – Tip
Slot 5	2	J1-14	2	Loop A – Ring
Slot 5	3	J1-40	3	Loop B – Tip
Slot 5	4	J1-13	4	Loop B – Ring
Slot 6	5	J1-42	1	Loop A – Tip
Slot 6	6	J1-17	2	Loop A – Ring
Slot 6	7	J1-43	3	Loop B – Tip
Slot 6	8	J1-16	4	Loop B – Ring
Slot 7	9	J145	1	Loop A – Tip
Slot 7	10	J1-20	2	Loop A – Ring
Slot 7	11	J1-46	3	Loop B – Tip
Slot 7	12	J1-19	4	Loop B – Ring
Slot 8	13	J1-48	1	Loop A – Tip
Slot 8	14	J1-23	2	Loop A – Ring
Slot 8	15	J1-49	3	Loop B – Tip
Slot 8	16	J1-22	4	Loop B – Ring
Slot 9	17	J2-27	1	Loop A – Tip
Slot 9	18	J2-2	2	Loop A – Ring
Slot 9	19	J2-28	3	Loop B – Tip
Slot 9	20	J2-1	4	Loop B – Ring
Slot 10	21	J2-30	1	Loop A – Tip
Slot 10	22	J2-5	2	Loop A – Ring

**Slot 1–16 Analog Connector (P7) 64-pin to  
two 50-Pin Connector Conversion (3 of 3)**

<b>Card Cage Slot</b>	<b>64-pin (P7) Connector Pin Number</b>	<b>50-pin Connector Pin Number</b>	<b>356-Type Modular RJ48 Adapter Pin Number</b>	<b>Function</b>
Slot 10	23	J2-31	3	Loop B – Tip
Slot 10	24	J2-4	4	Loop B – Ring
Slot 11	25	J2-33	1	Loop A – Tip
Slot 11	26	J2-8	2	Loop A – Ring
Slot 11	27	J2-34	3	Loop B – Tip
Slot 11	28	J2-7	4	Loop B – Ring
Slot 12	29	J2-36	1	Loop A – Tip
Slot 12	30	J2-11	2	Loop A – Ring
Slot 12	31	J2-37	3	Loop B – Tip
Slot 12	32	J2-10	4	Loop B – Ring
Slot 13	49	J2-39	1	Loop A – Tip
Slot 13	50	J2-14	2	Loop A – Ring
Slot 13	51	J2-40	3	Loop B – Tip
Slot 13	52	J2-13	4	Loop B – Ring
Slot 14	53	J2-42	1	Loop A – Tip
Slot 14	54	J2-17	2	Loop A – Ring
Slot 14	55	J2-43	3	Loop B – Tip
Slot 14	56	J2-16	4	Loop B – Ring
Slot 15	57	J2-45	1	Loop A – Tip
Slot 15	58	J2-20	2	Loop A – Ring
Slot 15	59	J2-46	3	Loop B – Tip
Slot 15	60	J2-19	4	Loop B – Ring
Slot 16	61	J2-48	1	Loop A – Tip
Slot 16	62	J2-23	2	Loop A – Ring
Slot 16	63	J2-49	3	Loop B – Tip
Slot 16	64	J2-22	4	Loop B – Ring

## SDSL Local Loop Cable Pinouts

**Slot 1–16 Analog Connector (P7) 64-pin to two 50-Pin Connector Conversion (1 of 2)**

Card Cage Slot	64-pin (P7) Connector Pin Number	50-pin Connector Pin Number	356-Type Modular RJ48 Adapter Pin Number	Function
Slot 1	48	J1-27	1	Loop – Tip
Slot 1	47	J1-2	2	Loop – Ring
Slot 2	44	J1-30	1	Loop – Tip
Slot 2	43	J1-5	2	Loop – Ring
Slot 3	40	J1-33	1	Loop – Tip
Slot 3	39	J1-8	2	Loop – Ring
Slot 4	36	J1-36	1	Loop – Tip
Slot 4	35	J1-11	2	Loop – Ring
Slot 5	1	J1-39	1	Loop – Tip
Slot 5	2	J1-14	2	Loop – Ring
Slot 6	5	J1-42	1	Loop – Tip
Slot 6	6	J1-17	2	Loop – Ring
Slot 7	9	J1-45	1	Loop – Tip
Slot 7	10	J1-20	2	Loop – Ring
Slot 8	13	J1-48	1	Loop – Tip
Slot 8	14	J1-23	2	Loop – Ring
Slot 9	17	J2-27	1	Loop – Tip
Slot 9	18	J2-2	2	Loop – Ring
Slot 10	21	J2-30	1	Loop – Tip
Slot 10	22	J2-5	2	Loop – Ring
Slot 11	25	J2-33	1	Loop – Tip
Slot 11	26	J2-8	2	Loop – Ring
Slot 12	29	J2-36	1	Loop – Tip
Slot 12	30	J2-11	2	Loop – Ring
Slot 13	49	J2-39	1	Loop – Tip
Slot 13	50	J2-14	2	Loop – Ring

**Slot 1–16 Analog Connector (P7) 64-pin to  
two 50-Pin Connector Conversion (2 of 2)**

<b>Card Cage Slot</b>	<b>64-pin (P7) Connector Pin Number</b>	<b>50-pin Connector Pin Number</b>	<b>356-Type Modular RJ48 Adapter Pin Number</b>	<b>Function</b>
Slot 14	53	J2-42	1	Loop – Tip
Slot 14	54	J2-17	2	Loop – Ring
Slot 15	57	J2-45	1	Loop – Tip
Slot 15	58	J2-20	2	Loop – Ring
Slot 16	61	J2-48	1	Loop – Tip
Slot 16	62	J2-23	2	Loop – Ring

---

# Glossary

---

<b>Champ connector</b>	64-pin connector used to connect the E1/T1 network or local loop to the HotWire 7900 Nest connectors J5, J6, and J7.
<b>CO</b>	Central Office/Central Site.
<b>COM port</b>	Communications port. A computer's serial communications port used to transmit to and receive data from a DCE. The DCE connects directly to this port.
<b>CP</b>	Customer Premises.
<b>CPE</b>	Customer Premises Equipment. Terminating equipment supplied by either the customer or some other supplier that is connected to the telecommunications network (e.g., DSUs, terminals, phones, routers, modems).
<b>E1</b>	A data signaling rate common outside the United States. A wideband interface operating at 2.048 Mbps defined by CCITT standards G.703 and G.704.
<b>factory defaults</b>	A predetermined set of configuration options for general operation.
<b>FCC</b>	Federal Communications Commission. Board of Commissioners that regulates all U.S. interstate, intrastate, and foreign electrical communication systems that originate from the United States.
<b>G.703</b>	ITU-TS standard for covering transmission facilities.
<b>HDSL</b>	High-bit-rate Digital Subscriber Loop. Provides high bandwidth, bi-directional transmission over copper wire for both T1 and E1 services.
<b>HTU</b>	Host Termination Unit. A generic reference to either an HTU-C or HTU-R module.
<b>HTU-C</b>	Host Termination Unit – Central. The module at the CO (central office) or central site end of an HDSL connection. Also known as a Network Termination Unit (NTU).
<b>HTU-M</b>	Host Termination Unit – Maintenance. A carrier-mounted module used to perform maintenance operations on one or more HTU-R and HTU-C modules.
<b>HTU-R</b>	Host Termination Unit – Remote. The module at the CP (customer premises) end of an HDSL connection. Also known as a Line Termination Unit (LTU).
<b>HTU-S</b>	Host Termination Unit – SNMP. The SNMP-compatible version of the Maintenance Processor.
<b>LED</b>	Light Emitting Diode. A status indicator that responds to the presence of a certain conditions.
<b>loopback</b>	Used to test various portions of a data link in order to isolate an equipment or data line problem. A diagnostic procedure that sends a test message back to its origination point.
<b>SDSL</b>	Symmetrical Digital Subscriber Loop. Provides high bandwidth, bi-directional transmission over copper wire for both T1 and E1 services using 2 wires.
<b>SNMP</b>	Simple Network Management Protocol.
<b>STU</b>	SDSL Termination Unit. A generic reference to either an STU-C or STU-R module.
<b>STU-C</b>	SDSL Termination Unit – Central. The module at the CO (central office) or central site end of an HDSL connection. Also known as a Network Termination Unit (NTU).

<b>STU-R</b>	SDSL Termination Unit – Remote. The module at the CP (customer premises) end of an HDSL connection. Also known as a Line Termination Unit (LTU).
<b>STU-S</b>	SDSL Termination Unit – SNMP. The SNMP-compatible version of the Maintenance Processor.
<b>T1</b>	A data signaling rate common in the United States. A term for a digital carrier facility used to transmit a DS1 formatted signal of 1.544 Mbps.
<b>V.35</b>	ITU-TS standard for a high-speed, 34-pin, DCE/DTE interface.

---

# Index

---

## A

About This Guide, iii  
    Document Purpose, iii  
    Document Summary, iii  
Options, 1-2

## C

Cable pin assignments, A-1  
    HDSL Local Loop Cable, A-3  
    SDSL Local Loop Cable, A-6  
    T1/E1 Network, A-1  
Cabling Procedures, 3-5  
    DSL Local Loop cable, 3-7  
    T1 or E1 Network, 3-5  
Connect the Nest to –48 Vdc Power, 3-8  
Connect the Nest to –48 Vdc Power, Connecting to  
    existing –48 Vdc Power, 3-8  
Connectors, rear panel, 3-3

## E

EMI Warnings, C

## G

glossary, GL-1–GL-4

## I

Installation Procedures  
    –48 Vdc Power supply, 3-8  
    DSL Local Loop, 3-7  
    E1/T1 Network Cables, 3-5  
    Equipment location within the nest, 3-1  
    Heat Deflector module, 3-4  
    Inspect equipment for damage, 2-2  
    Nest card termination units, 3-10  
    Nest Filler Panels, 3-11  
    Preparing for Installation, 2-1  
    Required tools, 2-2  
Installation procedures, HotWire 7900 Nest, 3-1  
Internet address, A

## N

Nest Filler Panels, 3-11

## O

Order of Installation, 2-2  
Overview, 1-1

## P

Power, 3-8  
    Applying Power, 3-10

## R

rear panel connectors, 3-3  
Related Documents, iv  
Required Tools, 2-2

## S

Safety Instructions, B  
Sales information, A  
Service Information, A

## W

Warranty, A