



AREA CODE CHANGE

Please note that the area code for Paradyne Corporation in Largo, Florida has changed from 813 to 727.

For any Paradyne telephone number that appears in this manual with an 813 area code, dial 727 instead.



**HOTWIRE
MODELS 7924 AND 7925
T1 AND E1 HDSL NEST CARD
TERMINATION UNITS**

USER'S GUIDE

Document No. 7920-A2-GB20-10

August 1997

Copyright © 1997 Paradyne Corporation.
All rights reserved.
Printed in U.S.A.

Notice

This publication is protected by federal copyright law. No part of this publication may be copied or distributed, transmitted, transcribed, stored in a retrieval system, or translated into any human or computer language in any form or by any means, electronic, mechanical, magnetic, manual or otherwise, or disclosed to third parties without the express written permission of Paradyne Corporation, 8545 126th Avenue North, P.O. Box 2826, Largo, Florida 33779-2826.

Paradyne Corporation makes no representation or warranties with respect to the contents hereof and specifically disclaims any implied warranties of merchantability or fitness for a particular purpose. Further, Paradyne Corporation reserves the right to revise this publication and to make changes from time to time in the contents hereof without obligation of Paradyne Corporation to notify any person of such revision or changes.

Changes and enhancements to the product and to the information herein will be documented and issued as a new release to this manual.

Trademarks

All products and services mentioned herein are the trademarks, service marks, registered trademarks or registered service marks of their respective owners.

Warranty, Sales, and Service Information

Contact your sales or service representative directly for any help needed. For additional information concerning warranty, sales, service, repair, installation, documentation, or training, use one of the following methods:

- **Via the Internet:** Visit the Paradyne World Wide Web site at <http://www.paradyne.com>
- **Via Telephone:** Call our automated call system to receive current information via fax or to speak with a company representative.
 - Within the U.S.A., call 1-800-870-2221
 - International, call 813-530-2340



Printed on recycled paper

Important Safety Instructions

1. Read and follow all warning notices and instructions marked on the product or included in the manual.
2. This product is intended to be used with a 3-wire grounding type plug – a plug which has a grounding pin. This is a safety feature. Equipment grounding is vital to ensure safe operation. Do not defeat the purpose of the grounding type plug by modifying the plug or using an adapter.
Prior to installation, use an outlet tester or a voltmeter to check the ac receptacle for the presence of earth ground. If the receptacle is not properly grounded, the installation must not continue until a qualified electrician has corrected the problem.
If a 3-wire grounding type power source is not available, consult a qualified electrician to determine another method of grounding the equipment.
3. Slots and openings in the cabinet are provided for ventilation. To ensure reliable operation of the product and to protect it from overheating, these slots and openings must not be blocked or covered.
4. Do not allow anything to rest on the power cord and do not locate the product where persons will walk on the power cord.
5. Do not attempt to service this product yourself, as opening or removing covers may expose you to dangerous high voltage points or other risks. Refer all servicing to qualified service personnel.
6. General purpose cables are provided with this product. Special cables, which may be required by the regulatory inspection authority for the installation site, are the responsibility of the customer.
7. When installed in the final configuration, the product must comply with the applicable Safety Standards and regulatory requirements of the country in which it is installed. If necessary, consult with the appropriate regulatory agencies and inspection authorities to ensure compliance.
8. A rare phenomenon can create a voltage potential between the earth grounds of two or more buildings. If products installed in separate buildings are **interconnected**, the voltage potential may cause a hazardous condition. Consult a qualified electrical consultant to determine whether or not this phenomenon exists and, if necessary, implement corrective action prior to interconnecting the products.
9. In addition, if the equipment is to be used with telecommunications circuits, take the following precautions:
 - Never install telephone wiring during a lightning storm.
 - Never install telephone jacks in wet locations unless the jack is specifically designed for wet locations.
 - Never touch un-insulated telephone wires or terminals unless the telephone line has been disconnected at the network interface.
 - Use caution when installing or modifying telephone lines.
 - Avoid using a telephone (other than a cordless type) during an electrical storm. There may be a remote risk of electric shock from lightning.
 - Do not use the telephone to report a gas leak in the vicinity of the leak.

EMI Warnings

WARNING:

This equipment has been tested and found to comply with the limits for a Class A digital device, pursuant to Part 15 of the FCC rules. These limits are designed to provide reasonable protection against harmful interference when the equipment is operated in a commercial environment. This equipment generates, uses, and can radiate radio frequency energy and, if not installed and used in accordance with the instruction manual, may cause harmful interference to radio communications. Operation of this equipment in a residential area is likely to cause harmful interference in which case the user will be required to correct the interference at his own expense.

The authority to operate this equipment is conditioned by the requirements that no modifications will be made to the equipment unless the changes or modifications are expressly approved by Paradyne Corporation.

WARNING:

To Users of Digital Apparatus in Canada:

This Class A digital apparatus meets all requirements of the Canadian interference-causing equipment regulations.

Cet appareil numérique de la classe A respecte toutes les exigences du règlement sur le matériel brouilleur du Canada.

Contents

About This Guide

- Document Purpose and Intended Audience iii
- Document Summary iii
- Product-Related Documents iv

1 About HotWire Models 7924 and 7925 Nest Card Termination Units

- HotWire Model 7924 and 7925 Features 1-1
 - HotWire Model 7924 Standard Features 1-1
 - Hotwire Model 7925 Standard Features 1-2
- HotWire Model 7924 Typical Configurations 1-2
- HotWire Model 7925 Typical Configurations 1-4
- User Interfaces 1-6

2 Installing HotWire Nest Card Termination Units

- Package Checklist 2-1
- Inspect the Shipping Container 2-1
- Installing Nest Card Termination Units 2-2
- Installing Nest Filler Panels 2-3

3 Customizing HotWire 7924 Nest Card Termination Units

- Changing Your Configuration Options 3-1
- Switchpack and Jumper Locations 3-2
- Switchpack Definitions 3-3
- Jumper Positions 3-4

4 Customizing HotWire 7925 Nest Card Termination Units

- Changing Your Configuration Options 4-1
- Switchpack and Jumper Locations 4-2
- Switchpack Definitions 4-3
- Jumper Positions 4-4

5 Monitoring Nest Card Termination Units

- What to Monitor 5-1
- Front Panel LEDs 5-2

A HotWire Model 7924 Worksheets

- Overview A-1
- DSX-1 to DSX-1 Configuration A-1
- DSX-1 Nest-to-Standalone V.35 Configuration A-2
 - Unframed Operation A-3
- HotWire 7924 Configuration Worksheet A-4

B HotWire Model 7925 Worksheets

- Overview B-1
- G.703-to-G.703 Configuration B-1
- G.703 to V.35 Configuration B-2
- HotWire 7925 Configuration Worksheet B-4

Glossary

Index

About This Guide

Document Purpose and Intended Audience

This guide describes the configuration, installation, and maintenance procedures for HotWire Model 7924-B1 and 7925-B1 T1 and E1 HDSL Nest Card Termination Units.

It is expected that readers of this document are central-site or special-service installation technicians or network engineers who have an understanding of digital subscriber line systems and High-bit-rate Digital Subscriber Loop (HDSL) transmission systems plus the deployment of such systems in a telephone company or private network environment.

Document Summary

Section	Description
Chapter 1	<i>About HotWire Models 7924 and 7925 Nest Card Termination Units.</i> Describes the features of HotWire 7924 and 7925 termination units and provides typical configurations.
Chapter 2	<i>Installing HotWire Nest Card Termination Units.</i> Describes the procedures for installing the HotWire Model 7900 nest card termination units and nest filler panels.
Chapter 3	<i>Customizing HotWire 7924 Nest Card Termination Units.</i> Provides procedures for modifying configuration options by using the terminal interface or DIP switches and jumpers on the nest card.
Chapter 4	<i>Customizing HotWire 7925 Nest Card Termination Units.</i> Provides procedures for modifying configuration options by using the terminal interface or DIP switches and jumpers on the board.
Chapter 5	<i>Monitoring Nest Card Termination Units.</i> Describes how to monitor LEDs, unit, and network status.

Section	Description
Appendix A	<i>HotWire Model 7924 Worksheets.</i> Contains all the configuration options, default settings, and possible settings to use for planning.
Appendix B	<i>HotWire Model 7925 Worksheets.</i> Contains all the configuration options, default settings, and possible settings to use for planning.
Glossary	Defines the acronyms and terms used in this document.
Index	Lists the key terms, acronyms, and concepts, in alphabetical order.

Product-Related Documents

Document Number	Document Title
7900-A2-GB20	<i>HotWire Model 7900 Basic Maintenance Processor User's Guide</i>
7900-A2-GB21	<i>HotWire Model 7900 SNMP Maintenance Processor User's Guide</i>
7900-A2-GK10	<i>HDSL Connection Considerations Special Notice</i>
7900-A2-GN20	<i>HotWire Model 7900 Nest and Options Installation Guide</i>
7910-A2-GB20	<i>HotWire Models 7914 and 7915 T1 & E1 SDSL Nest Cards User's Guide</i>
7924-A2-GB20	<i>HotWire Model 7924 Standalone T1 HSDL Termination Unit Users Guide</i>
7925-A2-GB20	<i>HotWire Model 7925 Standalone E1 HSDL Termination Unit Users Guide</i>

To order additional product documentation, refer to [Warranty, Sales, and Service Information](#) on page A at the beginning of this User's Guide.

About HotWire Models 7924 and 7925 Nest Card Termination Units

1

HotWire Model 7924 and 7925 Features

Products in the HotWire 7900 family provide “last mile/last kilometer” transport of T1- and E1-compatible circuits between customer facilities and central-site equipment over 2- or 4-wire copper lines. These termination units can be used over distances substantially exceeding traditional T1 and E1 spans and European Telecommunications Standards Institute (ETSI) loop standards.

This chapter provides a general overview of the HotWire Models 7924 and 7925 nest card termination units, including standalone units (A1) and nest-mounted termination units (B1).

HotWire Model 7924 Standard Features

- DSX-1 interface
- Full support for T1 using two twisted-copper pairs
- Full support for fractional T1 using one or two twisted-copper pairs
- Meets the requirements of repeaterless T1 transmission on loops exceeding standard specifications
- Automatic detection of and compensation for inverted pairs and swapped loops, significantly simplifying installation
- Local and remote alarm surveillance
- Local and remote T1 and HDSL performance monitoring

Hotwire Model 7925 Standard Features

- G.703 interface
- Meets the requirements of repeaterless E1 transmission on loops exceeding standard specifications (up to 10 km on a 0.9 mm wire)
- Automatic detection and compensation for inverted pairs and swapped loops – significantly simplifies installation
- Local and remote alarm surveillance and performance monitoring
- Local and remote E1 and HDSL performance monitoring

You can order HotWire 7924 and 7925 products as standalone units (7924-A1/7925-A1) or as nest-mounted circuit card assemblies (CCAs) (7924-B1/7925B1) that fit in the HotWire 7900 Nest. This guide describes the installation and maintenance procedures for the nest-mounted CCAs, Models 7924-B1 and 7925-B1. See *Product-Related Documents* in *About This Guide* for information on user manuals for the standalone units.

HotWire Model 7924 Typical Configurations

HotWire Model 7924 termination units can be used in campus applications where long loop distances normally require the campus to contract with the local telephone exchange carrier to deliver private-line services across the campus.

Figure 1-1 shows a central-site application with a HotWire 7900 Nest containing HotWire Model 7924 Nest Card Termination Units. Each nest card terminates a single subscriber line in the central site. Each line is then converted to a DSX-1 interface for connection to other central-site equipment, such as a digital cross-connect system (DCS).

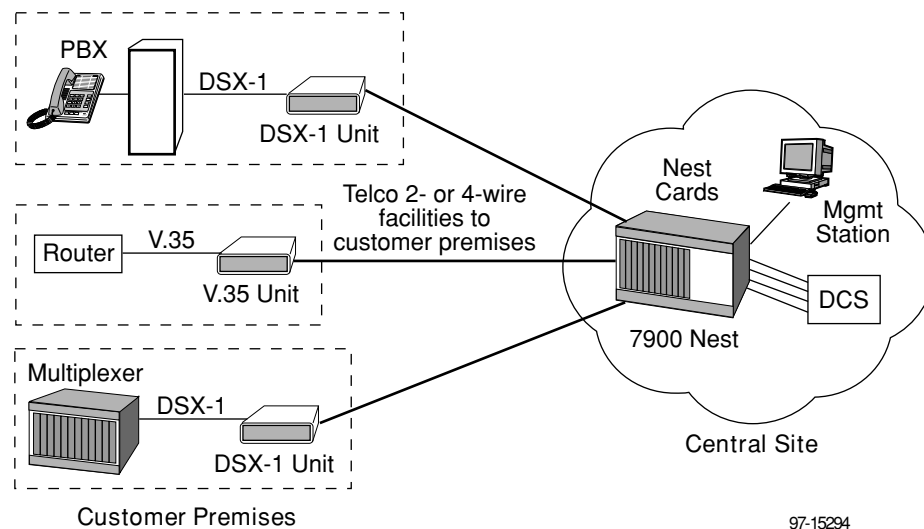

Figure 1-1. T1 Extension to Customer Premises

Cellular network providers must lease large numbers of T1 circuits in order to connect remote cell sites to mobile telephone switching offices (MTSOs). HotWire Model 7924 products provide an alternative to standard repeated T1 services. **Figure 1-2** depicts a typical cellular network access application.

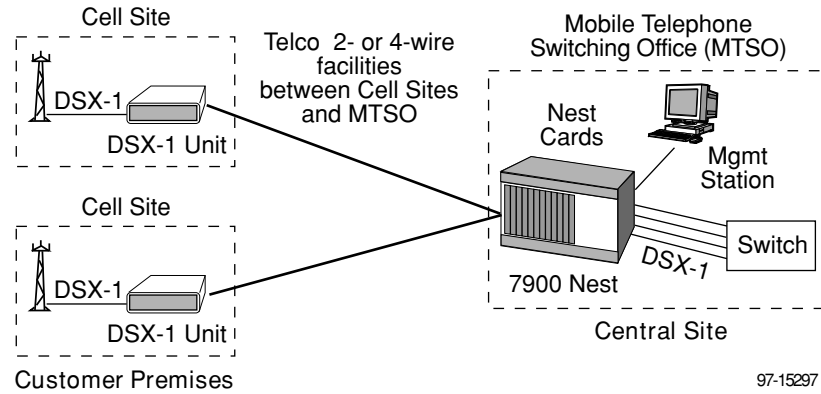

Figure 1-2. Cellular Network Access

Figure 1-3 shows two typical campus applications where remote routers or multiplexers are interconnected across a campus using two HotWire Model 7924 standalone units. In each pair, one unit is configured as a central site and the other as the remote customer premises.

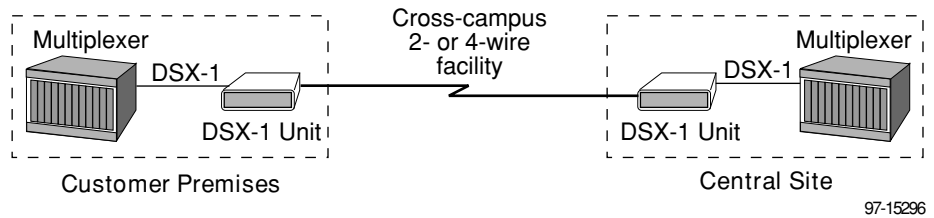
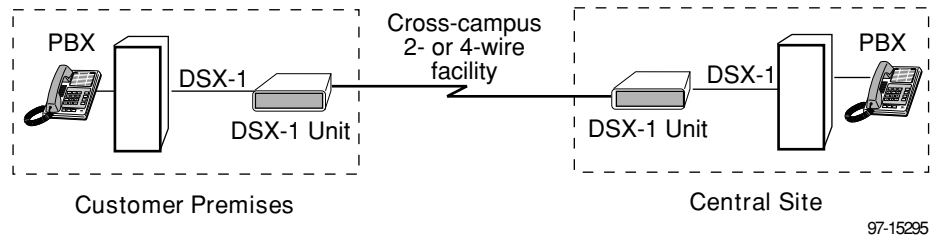

Figure 1-3. Campus Network Applications

HotWire Model 7924 standalone units are ideal for delivering T1 services from a central site to the customer premises over long loop distances without repeaters.

HotWire Model 7925 Typical Configurations

Figure 1-4 shows a central-site application with a HotWire 7900 Nest containing HotWire Model 7925 nest card termination units. The nest card termination units each terminate a single subscriber line in the central site. Each line is then converted to a G.703 interface for connection to other central-site equipment, such as a digital cross-connect system (DCS).

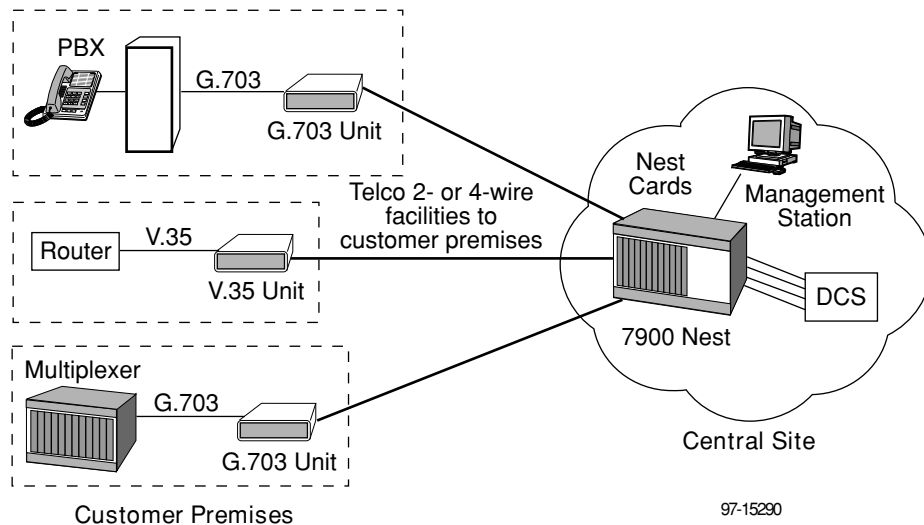

Figure 1-4. E1 Extension to Customer Premises

Cellular network providers must lease large numbers of E1 circuits in order to connect remote cell sites to mobile telephone switching offices (MTSOs). HotWire Model 7925 products provide an alternative to standard repeatered E1 services. Figure 1-5 depicts a typical G.703 cellular network access application.

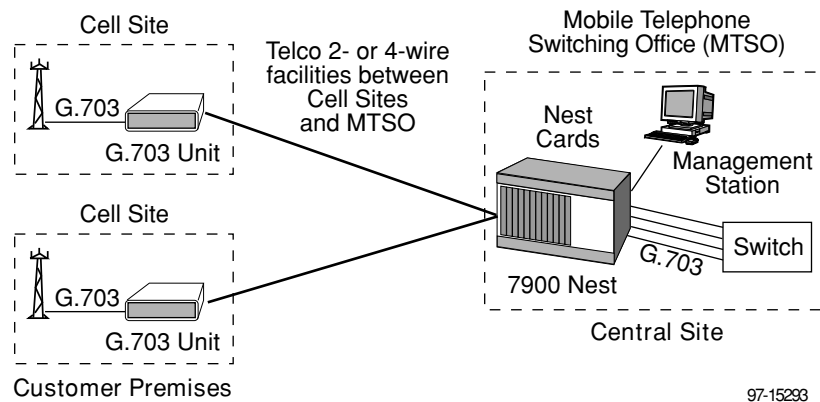

Figure 1-5. Cellular Network Access

HotWire Model 7925 termination units can be used in campus applications where long loop distances normally require the campus to contract with the local telephone exchange carrier to deliver private line services across the campus. **Figure 1-6** shows two typical campus applications where remote routers or multiplexers are interconnected across a campus using two HotWire Model 7925 termination units. In each pair, one unit is configured as a central site and the other as the customer premises.

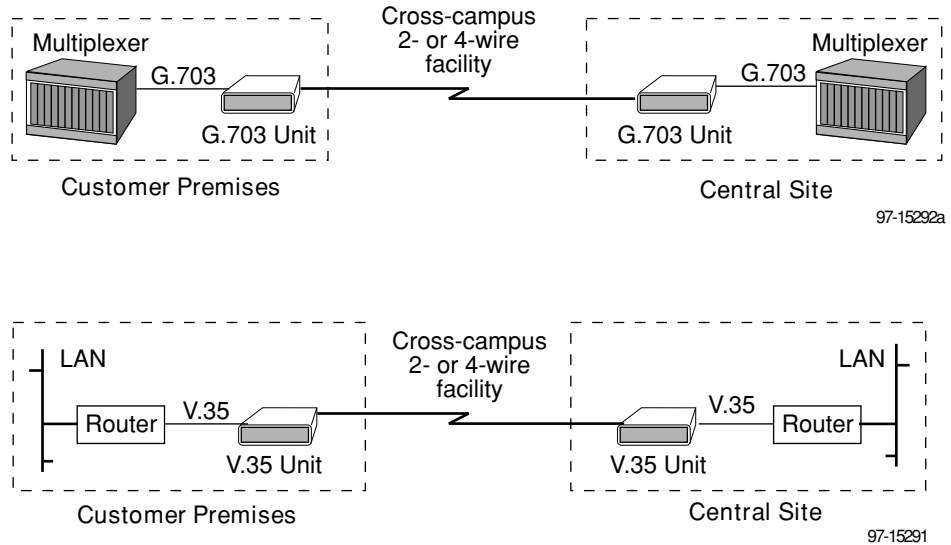

Figure 1-6. Campus Network Applications

HotWire Model 7925 termination units are ideal for delivering E1 services from a central site to the customer premises over long loop distances without repeaters.

Each HotWire Model 7924 and 7925 nest card termination unit is configured at the factory to operate at the central site (CO) of a T1 or E1 HDSL connection. However, you can reconfigure the unit for customer premises (CP) operation if required.

User Interfaces

There are two types of user interfaces to the nest card termination units:

- Switches and jumpers (refer to [Chapters 3 and 4](#))
- Front Panel LED status indicators (refer to [Chapter 5](#))

If you have an HTU-M or HTU-S maintenance processor, you can also monitor nest card termination units and network status using:

- The HTU-M or HTU-S front panel LEDs
- A VT100-terminal connected to the HTU-M or HTU-S maintenance processor.

Installing HotWire Nest Card Termination Units

2

Package Checklist

Verify that your package contains the following:

- The correct number of HotWire Models 7924 or 7925 nest card termination units (verify this with your packing list)
- Warranty card

Inspect the Shipping Container

Inspect the shipping container for signs of damage. Specific signs to check for are:

- Major tears or puncture holes on the sides of the container
- Splits in the seams
- Corner damage or any additional signs of the container having been dropped

If the shipping container shows signs of damage, report this immediately to your shipping or service representative.

Installing Nest Card Termination Units

It is assumed that you have already installed the HotWire Model 7900 Nest and associated power supply in a standard equipment rack, and that all network connections have been made. Installation of the optional HotWire 7900 Basic Maintenance Processor (HTU-M or HTU-S) is described in a separate user's guide. Refer to *Product-Related Documents* in *About This Guide*.

► Procedure

To install the nest card:

1. Use electrostatic discharge (ESD) protection when handling the electronic components. Remove the card from any protective packaging.
2. Align the circuit board with the top and bottom card guides of the next available card slot:
 - Slot 1 if no maintenance processor option is installed
 - Slot 2 if an HTU-S is installed in Slot 1
 - Slot 3 if an HTU-M is installed in Slots 1 and 2
3. Slide the nest card into the slot until the backplane connector plug is seated firmly into the backplane.
4. Tighten retaining screws at the top and bottom of the nest card front panel.

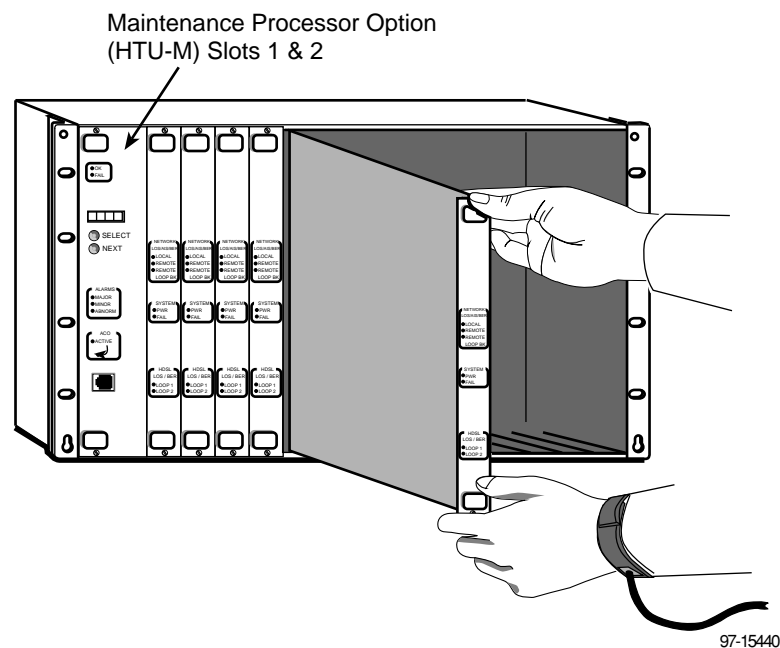

Installing Nest Filler Panels

Nest filler panels are required to be installed in slots that do not contain nest cards.

▲ WARNING:

Front Panel Fillers are required to be installed for EMI safety purposes. Install nest filler panels to cover all nest card slots that do not contain nest cards.

► Procedure

To install nest filler panels:

1. Align the filler panel with the retaining screw holes located at the top and bottom of the nest.
2. Tighten filler panel retaining screws.
3. Repeat until all empty nest-card slots are covered.



97-15537

Customizing HotWire 7924 Nest Card Termination Units

3

Changing Your Configuration Options

This chapter provides instructions on how to change or verify the configuration options for DSX-1-compatible HotWire 7924 T1 nest cards. [Chapter 4](#) provides configuration options for G.703-compatible HotWire 7925 E1 nest cards.

Configuration option settings determine how the unit operates. You can change the unit's configuration options by changing switchpack and jumper settings on the circuit card assembly.

► Procedure

To change and verify configuration options:

1. Loosen retaining screws at the top and bottom of the nest card.
2. Use electrostatic discharge (ESD) protection when handling the electronic components. Remove the card from the nest.
3. Use [Figure 3-1](#) to locate switchpack S1.
4. Place the switchpack DIP switches in the ON or OFF position for each desired configuration option. For example, to change a unit's card type from CO to CP, move DIP switch 1 on switchpack 1 to the OFF position.
 - P12 is positioned at the factory on Pins 1–2 (switchpack S1 disabled). To enable switchpack S1, move the jumper on P12 to Pins 2–3.
5. Return the nest card to the nest.
6. Tighten retaining screws at the top and bottom of the nest card.

Switchpack and Jumper Locations

Use [Figure 3-1](#) to locate HotWire 7924 nest card jumpers and switchpack S1.

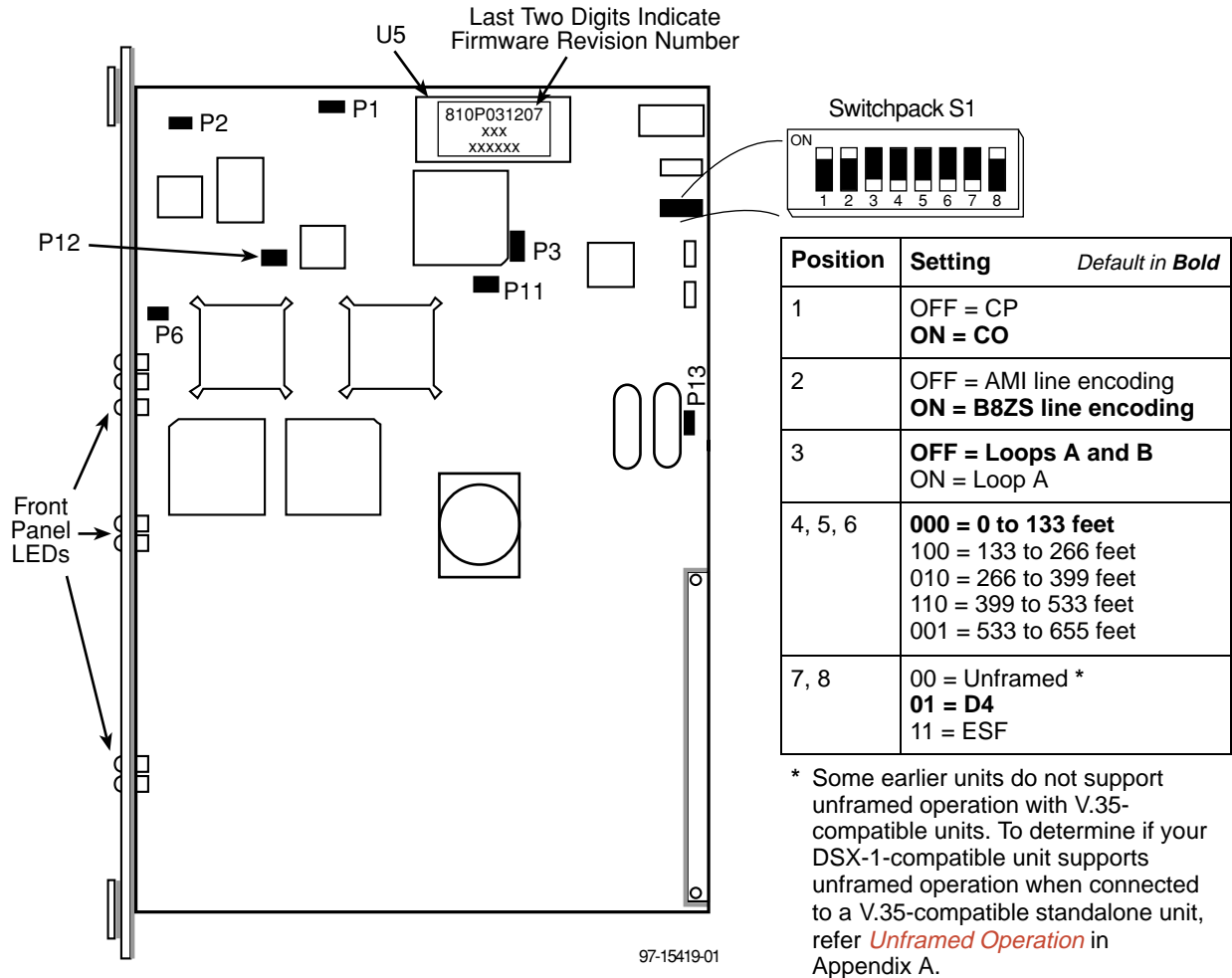

Figure 3-1. HotWire 7924 Nest Card Switchpack and Jumper Locations

- Pin 1 on jumpers is labeled on the board.
- The ON position is labeled on the switchpack.
- The jumper on P12 is positioned at the factory on Pins 1–2 (switchpack S1 disabled). To enable switchpack S1, move the jumper on P12 to Pins 2–3.
- Positions 4, 5, and 6 work as a trio. Set position 4 to the first digit, position 5 to the second digit, and position 6 to the last digit. For example, set 4 and 5 ON and 6 OFF for 399–533 feet.
- Positions 7 and 8 on Switchpack S1 work as a pair. Set position 7 to the first digit and position 8 to the second digit.

Switchpack Definitions

Change configuration options by moving switchpack S1 DIP switches on the nest card hardware.

Switchpack S1 Definitions	
Position # . . .	Allows you to . . . <i>Default in Bold</i>
1	Control whether the board is an HTU-C (CO) or an HTU-R (CP). OFF = CP ON = CO
2	Control enabling and disabling of zeroes suppression in the line code. OFF = AMI line encoding ON = B8ZS line encoding
3	Change the DSL local loop configuration. OFF = Loops A and B enabled ON = Loop A enabled
4, 5, and 6	Change Line Build-out configuration. 000 = 0 to 133 feet 100 = 133 to 266 feet 010 = 266 to 399 feet 110 = 399 to 533 feet 001 = 533 to 655 feet Positions 4, 5, and 6 form a three-digit binary number where ON represents a value of 1 and OFF represents a value of 0. For example, set 4 and 5 ON and 6 OFF for 399 to 533 feet.
7, 8	Control whether data is transmitted with or without framing. 00 = Unframed * 01 = D4 11 = ESF Positions 7 and 8 form a two-digit binary number where ON represents a value of 1 and OFF represents a value of 0. For example, set 7 OFF and 8 ON for D4 framing. NOTE: Operating unframed while T1 service is framed will result in the loss of reporting certain performance statistics, for example, CRC. Configure your HotWire equipment to match the T1 network. If your T1 service is framed, configure your HotWire 7900 nest cards as framed. If your T1 service is unframed, configure your HotWire 7900 nest cards as unframed.
* Some earlier units do not support unframed operation with V.35-compatible units. To determine if your DSX-1-compatible unit supports unframed operation when connected to a V.35-compatible standalone unit, refer to <i>Unframed Operation</i> in Appendix A, <i>HotWire Model 7924 Worksheets</i> .	

Jumper Positions

The following table provides the correct default jumper positions for your nest card.

Jumper	Position
P1	No jumper
P2	1-2
P3	2-3
P6	No jumper
P11	1-2
P12	1-2
P13	1-2

Customizing HotWire 7925 Nest Card Termination Units

4

Changing Your Configuration Options

This chapter provides instructions on how to change or verify configuration options for G.703-compatible HotWire 7925 E1 nest cards. [Chapter 3](#) provides configuration options for DSX-1-compatible HotWire 7924 T1 nest cards.

Configuration option settings determine how the unit operates. You can change the unit's configuration options by changing switchpack and jumper settings on the nest card.

► Procedure

To change or verify configuration options:

1. Loosen retaining screws at the top and bottom of the nest card.
2. Use electrostatic discharge (ESD) protection when handling the electronic components. Remove the card from the nest.
3. Use [Figure 4-1](#) to locate switchpack S1.
4. Place the switchpack DIP switches in the ON or OFF position for each desired configuration option. For example, to change a unit's card type from CO to CP, move DIP switch 1 on switchpack 1 to the OFF position.
 - The jumper on P12 is positioned at the factory on Pins 1–2 (switchpack S1 disabled). To enable switchpack S1, move the jumper on P12 to Pins 2–3.
5. Return the nest card to the nest.
6. Tighten retaining screws at the top and bottom of the nest card.

Switchpack and Jumper Locations

Use [Figure 4-1](#) to locate HotWire 7925 nest card jumpers and switchpack S1.

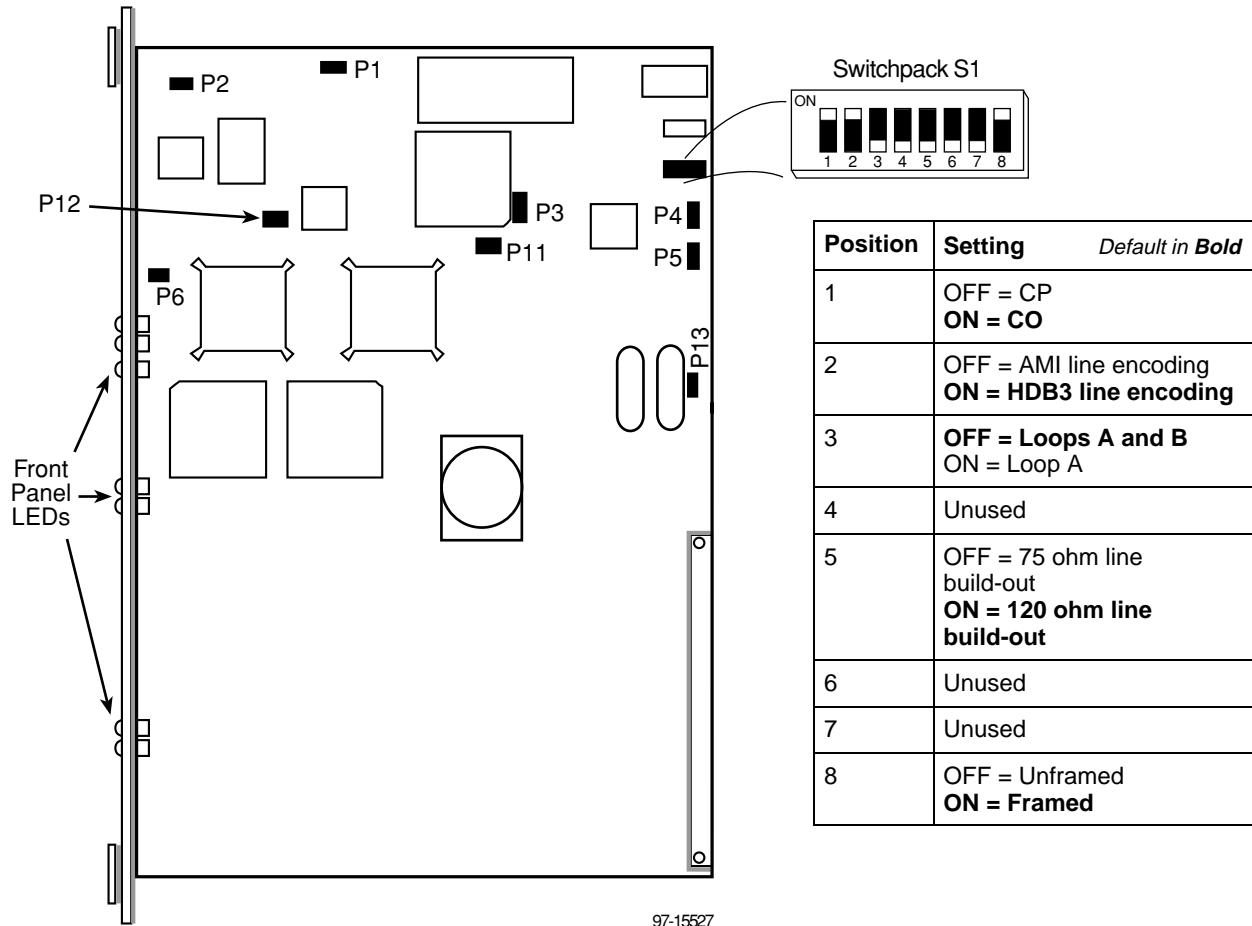

Figure 4-1. HotWire 7925 Nest Card Switchpack Locations and Jumper Positions

- Pin 1 on jumpers is labeled on the board.
- The ON position is labeled on the switchpack.
- The jumper on P12 is positioned at the factory on Pins 1–2 (switchpack S1 disabled). To enable switchpack S1, move the jumper on P12 to Pins 2–3.

Switchpack Definitions

Change configuration options by moving switchpack S1 DIP switches on the nest card hardware.

Switchpack S1 Definitions	
Position # . . .	Allows you to . . . <i>Default in Bold</i>
1	Control whether the board is an HTU-C (CO) or an HTU-R (CP). OFF = CP ON = CO
2	Control enabling and disabling of zeroes suppression in the line code. OFF = AMI line encoding ON = HDB3 line encoding
3	Change HDSL Local Loop configuration. OFF = Loops A and B enabled ON = Loop A enabled
4	Unused
5	Change the Line Build-out configuration. OFF = 75 ohm line build-out ON = 120 ohm line build-out
6	Unused
7	Unused
8	Control whether the data is transmitted with or without framing. OFF = Unframed ON = Framed NOTE: Operating unframed while E1 service is framed will result in the loss of reporting certain performance statistics, for example, CRC. Configure your HotWire equipment to match the E1 network. For example, if your E1 service is framed, configure your HotWire 7900 nest cards as framed. If your E1 service is unframed, configure your HotWire 7900 nest cards as unframed.

Jumper Positions

The following table provides the correct default jumper positions for your nest card.

Jumper	Position
P1	No jumper
P2	1-2
P3	2-3
P4	1-2
P5	1-2
P6	No jumper
P11	1-2
P12	1-2
P13	1-2

Monitoring Nest Card Termination Units

5

What to Monitor

Front panel LEDs on each HotWire Model 7924 and 7925 Nest Card Termination Unit provide status information about the nest card, HDSL local loop, and the T1 or E1 network interface. This chapter presents information on how to monitor and interpret the HotWire 7924 and 7925 nest card termination unit front panel LEDs.

You can also monitor loop status, change operational parameters, or initiate loopback testing from the Maintenance Processor (HTU-M or HTU-S) Front Panel or from a VT100-compatible terminal connected to the HTU-M or HTU-S by using the Maintenance, Performance, or Status options from the Main Menu.

The HTU-M and HTU-S maintenance processors:

- Monitor the status of up to 62 or 63 (HTU-S option only) nest card termination units
- Store the performance history of individual circuits and network status
- Monitor and display individual circuit and loop status on the maintenance processor front panel
- Display individual circuit and loop status on the VT100-compatible terminal or PC running a VT100-compatible terminal emulator program

The HTU-S maintenance processor:

- Interfaces with and reports circuit status to your Network Management System using Simple Network Management Protocol (SNMP)

For more information on the maintenance processor, refer to the *HotWire Model 7900 Basic Maintenance Processor User's Guide*.

Front Panel LEDs

When power is applied to the nest card, the top three LEDs (LOCAL, REMOTE, and LOOP BK) blink once in sequence and then remain off, indicating a successful start configuration.

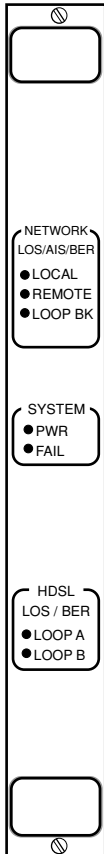

97-15441

LED . . .	Blinks or remains on when . . .
LOCAL	The local T1 or E1 interface has a loss of signal.
REMOTE	The remote T1 or E1 interface has a loss of signal.
LOOP BK	A loopback has been initiated for testing the equipment connected to this unit.
PWR	Power is applied to the unit.
FAIL	The processor has halted and repairs are required.
LOOP A	HDSL Loop A has failed. (The LED will blink at board power up until the loop has been synchronized.)
LOOP B	HDSL Loop B has failed or has been disabled. (The LED will blink at board power up until the loop has been synchronized.)

HotWire Model 7924 Worksheets

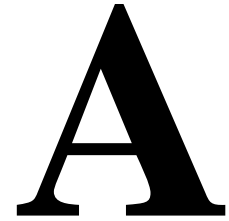

Overview

The following worksheets illustrate HotWire 7924-B1 configuration settings based on the types of connection. There are two connection combinations for HotWire 7924 nest card termination units:

- DSX-1-compatible units on both ends
- V.35-compatible unit on the customer premises (CP) end, DSX-1-compatible unit on the central office (CO) end

DSX-1 to DSX-1 Configuration

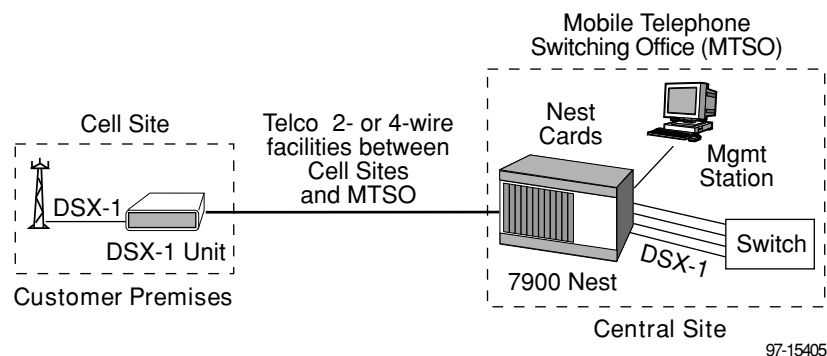

To connect two DSX-1-compatible units, configure the units as follows (factory defaults are in bold):

Configuration Option	DSX-1-Compatible Unit (Customer Premises)	DSX-1-Compatible Unit (Central Site)
Card Type	CP	CO
Loops Enabled	Dual (Loops A and B) or Single (Loop A)	Must be same as CP side
T1 Line Encode	B8ZS or AMI	Must be same as CP side
Framing	D4 , Extended Superframe, or Unframed	D4 , Extended Superframe, or Unframed
Line Build-Out	1) 0 to 133 feet 2) 133 to 266 feet 3) 266 to 399 feet 4) 399 to 533 feet 5) 533 to 655 feet	1) 0 to 133 feet 2) 133 to 266 feet 3) 266 to 399 feet 4) 399 to 533 feet 5) 533 to 655 feet

DSX-1 Nest-to-Standalone V.35 Configuration

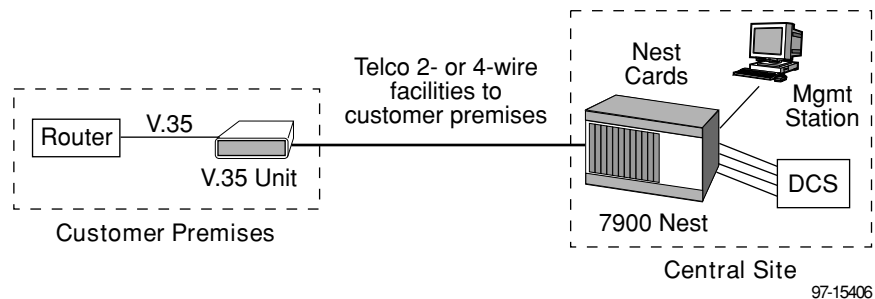

To connect a V.35-compatible standalone unit on the CP side and a DSX-1-compatible nest unit on the CO side, configure the units as follows (factory defaults are in bold):

Configuration Option	V.35-Compatible Unit (Customer Premises)	DSX-1-Compatible Unit (Central Site)
Card Type	CP	CO
Loops Enabled	Dual (Loops A and B) or Single (Loop A)	Must be same as CP side
Payload Rate	1 – 9 (64 – 1536 Kbps). Options 8 and 9 are only available if loops A and B are enabled.	N/A

Configuration Option	V.35-Compatible Unit (Customer Premises)	DSX-1-Compatible Unit (Central Site)
Framing ¹	N/A	If the payload rate is 1544 Kbps, use unframed. If the payload rate is less than 1544 Kbps, use D4 or ESF.
T1 Line Encode	N/A	B8ZS or AMI
Line Build-Out	N/A	1) 0 to 133 feet 2) 133 to 266 feet 3) 266 to 399 feet 4) 399 to 533 feet 5) 533 to 655 feet
¹ Refer to <i>UnFramed Operation</i> for unframed operation considerations.		

When the V.35 payload rate is set for less than 1536 Kbps, that payload rate determines which T1 DS0s are used, as follows:

V.35 Payload Rate	DSX-1 T1 DS0s Used
1 (64 Kbps)	1
2 (128 Kbps)	1, 2
3 (192 Kbps)	1 – 3
4 (256 Kbps)	1 – 4
5 (384 Kbps)	1 – 6
6 (512 Kbps)	1 – 8
7 (768 Kbps)	1 – 12
8 (1024 Kbps)	1 – 16

Unframed Operation

Some earlier units do not support unframed operation when connected to a V.35-compatible unit. To determine whether or not your DSX-1 nest card termination unit supports unframed operation when connected to a V.35-compatible unit, all three of the following conditions must be true:

1. The DSX-1 nest card termination unit must have a firmware revision number of 7 or higher.

The firmware revision number is the last two digits on the first line of the label located on the nest card EPROM located at U5. Refer to [Figure 3-1](#) in Chapter 3, for the location of the EPROM.

2. The V.35-compatible standalone unit must have an HDSL firmware revision number of 3 or higher.

To determine the firmware revision number of the V.35 standalone unit, look at the label on the bottom of the standalone unit that has the “CE” and “CSA” logos. The second row of numbers on this label should be “900P005705” or higher. The last two digits of this number (05) indicate the hardware revision number.

3. The V.35-compatible standalone unit must have a hardware revision number of 5 or higher.

To determine the hardware revision number, look at the label on the bottom of the standalone unit that has the “CE” and “CSA” logos. The second row of numbers on this label should be “900P005705” or higher. The last two digits of this number (05) indicate the hardware revision number.

HotWire 7924 Configuration Worksheet

Nest Card Configuration ¹	
Configuration Option	Settings <i>Default in Bold</i>
HDSL Card Type	CP, CO
Loops Enabled	Loops A and B , Loop A
T1 Line Encode	B8ZS , AMI
Line Build-Out	1) 0 to 133 feet – 0 2) 133 to 266 feet 3) 266 to 399 feet 4) 399 to 533 feet 5) 533 to 655 feet
Framing	D4 , Extended Super Frame, Unframed ²
¹ Refer to Chapter 3, <i>Customizing HotWire 7924 Nest Card Termination Units</i> , for information on switchpack location and configuration options. ² Refer to <i>UnFramed Operation</i> for unframed operation considerations.	

Nest Card Configuration	
Jumper	Settings <i>Default in [Bold]</i>
P12	(1, 2) Not used (2, 3) Switchpack enabled

HotWire Model 7925 Worksheets

B

Overview

The following worksheets illustrate HotWire 7925-B1 configuration settings based on the types of connection. There are two connection combinations for HotWire 7925 nest card termination units:

- G.703-compatible units on both ends
- V.35-compatible unit on the CP end, G.703-compatible unit on the CO end

G.703-to-G.703 Configuration

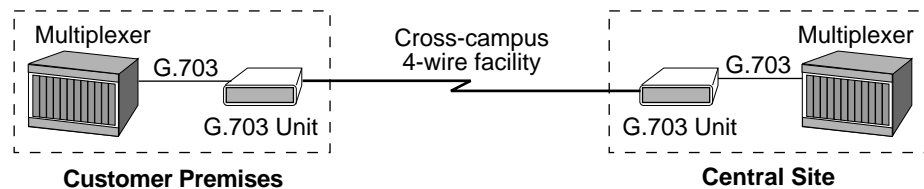

97-15292

To connect two G.703-compatible units, configure the units as follows (factory defaults are in bold):

Configuration Option	G.703-Compatible Unit (Customer Premises)	G.703-Compatible Unit (Central Site)
Card Type	CP	CO
Loops Enabled	Dual (Loops A and B) or Single (Loop A)	Must be same as CP side
E1 Line Encode	HDB3 or AMI	Must be same as CP side
Framing	Framed or Unframed	Framed or Unframed (does not need to be the same as the CP side)
Line Build-Out ¹	75 ohm or 120 ohm	75 ohm or 120 ohm (does not need to be the same as the CP side)
¹ Refer to <i>Switchpack Definitions</i> in Chapter 4 for more information on changing line build-out.		

G.703-to-V.35 Configuration

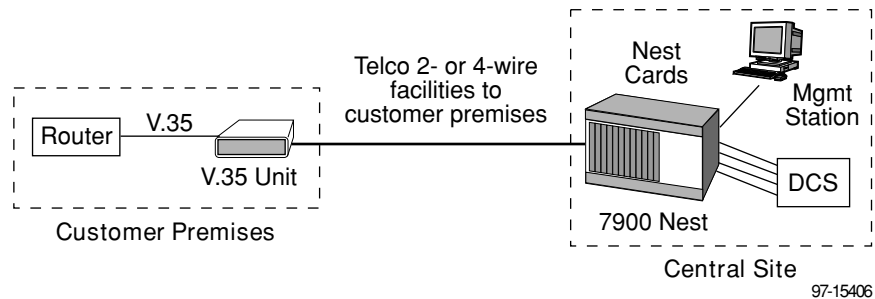

To connect a V.35-compatible standalone unit on the CP side and a G.703-compatible unit on the CO side, configure the units as follows (factory defaults are in bold):

Configuration Option	V.35-Compatible Unit (Customer Premises)	G.703-Compatible Unit (Central Site)
Card Type	CP	CO
Loops Enabled	Dual (Loops A and B) or Single (Loop A)	Must be same as CP side
Payload Rate	1 – 9 (64 – 2048 Kbps). Option 9 (2048 kbps) is only available if Loops A and B are enabled.	N/A
Transmit Timing	Loop	N/A

Configuration Option	V.35-Compatible Unit (Customer Premises)	G.703-Compatible Unit (Central Site)
Framing	N/A	If the payload rate is 2048 Kbps, use unframed. If the payload rate is less than 2048 Kbps, use framed.
E1 Line Encode	N/A	HDB3 or AMI
Line Build-Out ¹	N/A	75 ohm or 120 ohm
¹ Refer to <i>Switchpack Definitions</i> in Chapter 4 for more information on changing line build-out.		

When the V.35 payload rate is set for less than 2048 Kbps, that payload rate determines which E1 DS0's are used, as follows:

V.35 Payload Rate	G.703 E1 DS0s Used
1 (64 Kbps)	1
2 (128 Kbps)	1, 3
3 (192 Kbps)	1, 3, 5
4 (256 Kbps)	1, 3, 5, 7
5 (384 Kbps)	1, 3, 5, 7, 9, 11
6 (512 Kbps)	1, 3, 5, 7, 9, 11, 13, 15
7 (768 Kbps)	1, 3, 5, 7, 9, 11, 13, 15, 16, 18, 20, 22
8 (1024 Kbps)	1, 3, 5, 7, 9, 11, 13, 15, 16, 18, 20, 22, 24, 26, 28, 30

HotWire 7925 Configuration Worksheet

Nest Card Configuration ¹	
Configuration Option	Settings <i>Default in [Bold]</i>
HDSL Card Type	CP, CO
Loops Enabled	Loops A and B , Loop A
E1 Line Encode	HDB3 , AMI
Framing	Framed , Unframed
Line Build Out	75 ohm, 120 ohm
¹ Refer to Chapter 4, <i>Customizing HotWire 7925 Nest Card Termination Units</i> for information on switchpack location and configuration options.	

Nest Card Configuration	
Jumpers	Settings <i>Default in [Bold]</i>
J12	(1, 2) Not used (2, 3) Switchpack enabled

Glossary

AMI	Alternate Mark Inversion coding format.
BPV	Bipolar Violation. A type of error detected by using a modified bipolar signaling method in which a control code is inserted.
Bridged tap	A section of cable that was used to provide phone service to a home or business that is connected to a live copper wire but is not terminated.
CD	Carrier Detect. A signal indicating that energy exists on the transmission circuit. Associated with Pin 8 on an EIA-232 interface.
CO	Central Site or Central Office.
COM port	Communications port. A computer's serial communications port used to transmit to and receive data from a DCE. The DCE connects directly to this port.
CP	Customer Premises.
CPE	Customer Premises Equipment. Terminating equipment supplied by either the customer or some other supplier that is connected to the telecommunications network (e.g., DSUs, terminals, phones, routers, modems).
CRC	Cyclic Redundancy Check. A commonly used method of error detection.
CTS	Clear to Send. An EIA-lead standard for V.24 circuit CT 106; an output signal (DCE-to-DTE).
CV	Code Violation. This is equivalent to a BPV.
DCE	Data Communications Equipment. The equipment that provides the functions required to establish, maintain, and end a connection. It also provides the signal conversion required for communication between the DTE and the network.
DSR	Data Set Ready. An EIA-lead standard for V.24 circuit CT 107; an output signal (DCE-to-DTE).
DSX-1	Transmission standard at T1 speeds, 1544Mbits.
DTE	Data Terminal Equipment. The equipment, such as computers and printers, that provides or creates data.
DTR	Data Terminal Ready. An EIA-lead standard for V.24 circuit CT 108; an input signal (DTE-to-DCE).
E1	A data signaling rate common outside the United States. A wideband interface operating at 2.048 Mbps defined by CCITT standards G.703 and G.704.
ETSI	European Telecommunications Standards Institute. A European standards body established in 1988 by a decision of the CEPT (Conference of European Postal and Telecommunications Administrations).
factory defaults	A predetermined set of configuration options for general operation.
FCC	Federal Communications Commission. Board of Commissioners that regulates all U.S. interstate, intrastate, and foreign electrical communication systems that originate from the United States.
FEBE	Far End Bit Error. Number of errors reported by the remote equipment.

HDB3	High Density Bipolar 3 coding format.
HDSL	High-bit-rate Digital Subscriber Loop. Provides high bandwidth, bi-directional transmission over copper wire for both T1 and E1 services.
HTU	Host Termination Unit. A generic reference to either an HTU-C or HTU-R module.
HTU-C	Host Termination Unit – Central. The module at the CO (central office) or central site end of an HDSL connection. Also known as a Network Termination Unit (NTU).
HTU-M	Host Termination Unit – Maintenance. A carrier-mounted module used to perform maintenance operations on one or more HTU-R and HTU-C modules.
HTU-R	Host Termination Unit – Remote. The module at the CP (customer premises) end of an HDSL connection. Also known as a Line Termination Unit (LTU).
HTU-S	Host Termination Unit – SNMP. The SNMP-compatible version of the Maintenance Processor.
LED	Light Emitting Diode. A status indicator that responds to the presence of a certain condition.
loopback	Used to test various portions of a data link in order to isolate an equipment or data line problem. A diagnostic procedure that sends a test message back to its origination point.
MTSO	Mobile Telephone Switching Office.
OOF	Out Of Frame. An error condition in which frame synchronization bits are in error. A network-reported condition.
reset	A reinitialization of the device that occurs at power-up or in response to a reset command.
RTS	Request to Send. An EIA-lead standard for V.24 circuit CT 105; an input signal (DTE-to-DCE).
RXD	Received Data. An EIA-lead standard for V.24 circuit CT 104; an output signal (DCE-to-DTE).
SDSL	Symmetrical Digital Subscriber Loop. Provides high bandwidth, bi-directional transmission over copper wire for both T1 and E1 services using 2 wires.
SNMP	Simple Network Management Protocol.
STU	SDSL Termination Unit. A generic reference to either an STU-C or STU-R module.
STU-C	SDSL Termination Unit – Central. The module at the CO (central office) or central site end of an HDSL connection. Also known as a Network Termination Unit (NTU).
STU-R	SDSL Termination Unit – Remote. The module at the CP (customer premises) end of an HDSL connection. Also known as a Line Termination Unit (LTU).
STU-S	SDSL Termination Unit – SNMP. The SNMP-compatible version of the Maintenance Processor.
T1	A data signaling rate common in the United States. A term for a digital carrier facility used to transmit a DS1 formatted signal of 1.544 Mbps.
TXD	Transmit Data. An EIA-lead standard for V.24 circuit CT 103; an input signal (DTE-to-DCE).
V.35	ITU-T standard for a high-speed, 34-pin, DCE/DTE interface.

Index

C

Component location

- Model 7925 Jumpers, 4-2
- Model 7924 jumpers, 3-2
- Model 7924 switchpack S1, 3-2
- Model 7925 switchpack S1, 4-2

Configuration option overview

- G.703-to-G.703, B-1
- G.703-to-V.35, B-2

Configuration Options Table, Model 7924 T1, A-4

Configuration Options, Model 7925 E1, B-1

Configuration options, 3-1, 4-1

- Model 7924, A-1
- Model 7924 T1 nest cards, 3-1
- Model 7925 E1 nest cards, 4-1

Configuration Options Table, Model 7925 E1, B-4

Configuration overview, A-1, B-1

- DSX-1 Nest to Standalone V.35, A-2
- DSX-1 to DSX-1 Configuration, A-1

Configuration overviews, 1-2

- 7924 Configurations, 1-2
- 7925 Configurations, 1-4

Configuration Worksheet

- Model 7924 T1, A-4
- Model 7925 E1, B-4

D

Document purpose, iv

Document summary, iv

E

EMI Warnings, C

F

Features

- 7924 Features, 1-1
- 7925 Features, 1-2

G

glossary, GL-1–GL-4

I

Installation Procedures, Nest Filler Panels, 2-3

Installation procedures, Nest card termination units, 2-2

Intended audience, iv

Interfaces, 1-6

Internet address, A

J

Jumper positions, 3-4, 4-4

- Model 7924 jumper positions, 3-4
- Model 7925 jumper positions, 4-4

L

LEDs, 5-2

Line Build-out definitions, 3-3, 4-3

- Model 7924 T1, 3-3
- Model 7925 E1, 4-3

M

Monitoring HDSL Termination Units, 5-1

- Front Panel LEDs, 5-2
- What to Monitor, 5-1

N

Nest Filler Panels, 2-3

P

Package checklist, 2-1

Preinspection of equipment, 2-1

R

Related documents, v

S

Safety instructions, B

Sales information, A

Service information, A

Switchpack definitions, 3-3, 4-3

 Model 7924 switchpack S1 definitions, 3-3

 Model 7925 switchpack definitions, 4-3

Switchpack locations, 4-2

 Model 7924 switchpack S1, 3-2

 Model 7925 switchpack S1, 4-2

U

Unframed Operation, Restrictions on DSX-1 to V.35
use, A-3

W

Warranty information, A