



**HOTWIRE
MODEL 7925 STANDALONE
E1 HDSL TERMINATION UNIT
USER'S GUIDE**

Document No. 7925-A2-GB20-40

September 1997

Copyright © 1997 Paradyne Corporation.
All rights reserved.
Printed in U.S.A.

Notice

This publication is protected by federal copyright law. No part of this publication may be copied or distributed, transmitted, transcribed, stored in a retrieval system, or translated into any human or computer language in any form or by any means, electronic, mechanical, magnetic, manual or otherwise, or disclosed to third parties without the express written permission of Paradyne Corporation, 8545 126th Avenue North, P.O. Box 2826, Largo, Florida 33779-2826.

Paradyne Corporation makes no representation or warranties with respect to the contents hereof and specifically disclaims any implied warranties of merchantability or fitness for a particular purpose. Further, Paradyne Corporation reserves the right to revise this publication and to make changes from time to time in the contents hereof without obligation of Paradyne Corporation to notify any person of such revision or changes.

Changes and enhancements to the product and to the information herein will be documented and issued as a new release to this manual.

Trademarks

All products and services mentioned herein are the trademarks, service marks, registered trademarks or registered service marks of their respective owners.

Warranty, Sales, and Service Information

Contact your sales or service representative directly for any help needed. For additional information concerning warranty, sales, service, repair, installation, documentation, or training, use one of the following methods:

- **Via the Internet:** Visit the Paradyne World Wide Web site at <http://www.paradyne.com>
- **Via Telephone:** Call our automated call system to receive current information via fax or to speak with a company representative.
 - Within the U.S.A., call 1-800-870-2221
 - International, call 727-530-2340



Printed on recycled paper

Important Safety Instructions

1. Read and follow all warning notices and instructions marked on the product or included in the manual.
2. Do not allow anything to rest on the power cord and do not locate the product where persons will walk on the power cord.
3. Do not attempt to service this product yourself, as opening or removing covers may expose you to dangerous high voltage points or other risks. Refer all servicing to qualified service personnel.
4. General purpose cables are provided with this product. Special cables, which may be required by the regulatory inspection authority for the installation site, are the responsibility of the customer.
5. When installed in the final configuration, the product must comply with the applicable Safety Standards and regulatory requirements of the country in which it is installed. If necessary, consult with the appropriate regulatory agencies and inspection authorities to ensure compliance.
6. A rare phenomenon can create a voltage potential between the earth grounds of two or more buildings. If products installed in separate buildings are **interconnected**, the voltage potential may cause a hazardous condition. Consult a qualified electrical consultant to determine whether or not this phenomenon exists and, if necessary, implement corrective action prior to interconnecting the products.
7. In addition, if the equipment is to be used with telecommunications circuits, take the following precautions:
 - Never install telephone wiring during a lightning storm.
 - Never install telephone jacks in wet locations unless the jack is specifically designed for wet locations.
 - Never touch uninsulated telephone wires or terminals unless the telephone line has been disconnected at the network interface.
 - Use caution when installing or modifying telephone lines.
 - Avoid using a telephone (other than a cordless type) during an electrical storm. There may be a remote risk of electric shock from lightning.
 - Do not use the telephone to report a gas leak in the vicinity of the leak.

EMI Warnings

WARNING:

This equipment has been tested and found to comply with the limits for a Class A digital device, pursuant to Part 15 of the FCC rules. These limits are designed to provide reasonable protection against harmful interference when the equipment is operated in a commercial environment. This equipment generates, uses, and can radiate radio frequency energy and, if not installed and used in accordance with the instruction manual, may cause harmful interference to radio communications. Operation of this equipment in a residential area is likely to cause harmful interference in which case the user will be required to correct the interference at his own expense.

The authority to operate this equipment is conditioned by the requirements that no modifications will be made to the equipment unless the changes or modifications are expressly approved by Paradyne Corporation.

In order to maintain compliance with FCC Part 15 Rules, the ferrite choke must be installed on the V.35 cable. Refer to the installation instructions.

WARNING:

To Users of Digital Apparatus in Canada:

This Class A digital apparatus meets all requirements of the Canadian interference-causing equipment regulations.

Cet appareil numérique de la classe A respecte toutes les exigences du règlement sur le matériel brouilleur du Canada.

Contents

About This Guide

- Document Purpose and Intended Audience v
- Document Summary v
- Product-Related Documents vi

1 About HotWire Model 7925 Standalone Termination Units

- HotWire 7925 Models and Features 1-1
- Typical Configurations 1-3
- User Interface Types 1-5

2 Installing the Unit

- Package Checklist for HotWire Model 7925-A1 2-1
- Connecting to the Network 2-1
- Connecting Power to the Unit 2-2

3 Using Terminal and Switchpack Modes

- Choosing an Interface Mode 3-1
- Connecting to a System Terminal 3-1
- Switching Between Terminal and Switchpack Modes 3-2

4 Customizing G.703-Compatible Units

- Accessing Configuration Options 4-1
- Making Changes from the Terminal Interface 4-2
 - Displaying Switchpack Definitions 4-4
 - Displaying Line Build-Out Definitions 4-5
- Changing the Line Build-Out 4-5
- Making Changes in Switchpack Mode 4-6

5 Customizing V.35-Compatible Units

- Accessing Configuration Options 5-1
- Making Changes from the Terminal Interface 5-2
- Making Changes in Switchpack Mode 5-4
 - Displaying Switchpack Definitions 5-5

6 Monitoring the Unit

- What to Monitor 6-1
- Board Status 6-2
- Performance Statistics 6-3
- Remote Unit Information 6-5
- Front Panel LEDs 6-6
 - G.703-Compatible Unit 6-6
 - V.35-Compatible Unit 6-7

7 Testing

- Detecting a Problem 7-1
- Understanding Loopback Tests 7-1
 - Local Loopbacks 7-2
 - Remote Loopbacks 7-3
 - Starting and Ending Loopbacks 7-4
- Resetting the Unit 7-5

A Worksheets

- Overview A-1
- G.703-to-G.703 Configuration A-2
- V.35-to-V.35 Configuration A-3
- G.703-to-V.35 Configuration A-4
- G.703-Compatible Units Configuration Worksheet A-5
- V.35-Compatible Units Configuration Worksheet A-5

B Cable Pin Assignments

- Terminal Connection Cable Pin Assignments B-1
- HDSL Loop Connection Cable Pin Assignments B-2
- E1 Network 120 Ohm Connection Cable Pin Assignments B-3
- V.35 Connection Cable Pin Assignment B-4

C Switchpacks and Jumpers

- G.703-Compatible Units C-1
- V.35-Compatible Units C-3

Glossary

Index

About This Guide

Document Purpose and Intended Audience

This guide contains information needed to set up, configure, and operate HotWire Model 7925-A1 E1 HDSL termination units. It is designed for central office and/or special service installation technicians or network engineers who have an understanding of digital subscriber line systems and High-bit-rate Digital Subscriber Loop (HDSL) transmission systems plus the deployment of such systems in a telephone company or private network environment.

Document Summary

Section	Description
Chapter 1	<i>About HotWire Model 7925 Standalone Termination Units.</i> Describes the features of each version of the Model 7925 and typical configurations.
Chapter 2	<i>Installing the Unit.</i> Describes how to install the unit and make connections.
Chapter 3	<i>Using Terminal and Switchpack Modes.</i> Provides instructions for connecting a VT100-compatible terminal user interface. Also describes how to make manual configuration changes directly on the board hardware.
Chapter 4	<i>Customizing G.703-Compatible Units.</i> Provides instructions for modifying configuration options by using the terminal interface or DIP switches and jumpers on the board.
Chapter 5	<i>Customizing V.35-Compatible Units.</i> Provides instructions for modifying configuration options by using the terminal interface or DIP switches and jumpers on the board.
Chapter 6	<i>Monitoring the Unit.</i> Describes how to monitor unit status, LEDs, and network statistics. Also describes how to monitor the status of the unit on the opposite side of the HDSL connection.

Section	Description
Chapter 7	<i>Testing.</i> Provides information about available loopback tests.
Appendix A	<i>Worksheets.</i> Provides sample configurations and worksheets.
Appendix B	<i>Cable Pin Assignments.</i> Provides connector and interface details.
Appendix C	<i>Switchpacks and Jumpers.</i> Defines the switchpack and jumper positions on the board hardware. Includes board layout diagram.
Glossary	Defines acronyms and terms used in this document.
Index	Lists key terms, acronyms, concepts, and sections in alphabetical order.

Product-Related Documents

Document Number	Document Title
7900-A2-GB20	<i>HotWire Model 7900 Basic Maintenance Processor User's Guide</i>
7900-A2-GB21	<i>HotWire Model 7900 SNMP Maintenance Processor User's Guide</i>
7900-A2-GN20	<i>HotWire Model 7900 Equipment Nest and Options Installation Guide</i>
7920-A2-GN21	<i>HotWire Model 7900 Standalone Unit Nest Installation Guide</i>
7920-A2-GB20	<i>HotWire Models 7924 and 7925 T1 & E1 HDSL Nest Cards User's Guide</i>

To order additional product documentation, refer to [Warranty, Sales, and Service Information](#) on page A at the beginning of this User's Guide.

About HotWire Model 7925 Standalone Termination Units

1

HotWire 7925 Models and Features

Products in the HotWire 7925 family provide “last mile/last kilometer” transport of E1-compatible circuits between customer facilities and central site equipment over 2- or 4-wire copper lines. The units can be used over distances substantially exceeding traditional E1 spans and ETSI loop standards.

HotWire 7925 standard features include:

- V.35 or G.703 interface
- Local and remote alarm surveillance and performance monitoring
- Meets the requirements of repeaterless E1 transmission on loops exceeding standard specifications
- Automatically detects and compensates for inverted pairs and swapped loops, significantly simplifying installation
- Tolerates bridged tap

HotWire 7925 may be ordered either as a standalone unit (7925-A1-xxx) or as a nest-mounted card (7925-B1-xxx) that fits in a HotWire 7900 nest. This guide describes the installation and maintenance procedures for the standalone version, Model 7925-A1-xxx. See *Product-Related Documents* in *About This Guide* for information on manuals for the nest and nest-mounted cards.

Up to ten standalone units may be installed in an optional HotWire 7900 10-slot Standalone Shelf, using a single power source. (The Standalone Shelf is required for the –48 Vdc standalone model.)

There are several versions of the Model 7925-A1, each supporting a different interface (G.703 or V.35) and power supply (–48 Vdc, 230 Vac, or 120 Vac):

Model Number	Features
7925-A1-201	2Mb/s G.703 compatible. Connection to 120 Vac power supply.
7925-A1-202	2Mb/s V.35 compatible. Connection to 120 Vac power supply.
7925-A1-301	2Mb/s G.703 compatible. Connection to 230 Vac power supply.
7925-A1-302	2Mb/s V.35 compatible. Connection to 230 Vac power supply.
7925-A1-501	2Mb/s G.703 compatible. Direct connection to –48 Vdc power supply.
7925-A1-502	2Mb/s V.35 compatible. Direct connection to –48 Vdc power supply.

Typical Configurations

HotWire Model 7925 standalone units can be used in campus applications where long loop distances normally require the campus to contract with the local telephone exchange carrier to deliver high-speed services across the campus.

Figure 1-1 shows two typical campus applications where remote routers or multiplexers are interconnected across a campus using two HotWire Model 7925 standalone units. In each pair, one unit is configured as a central site or central office (CO) and the other is the remote (CP).

Each HotWire Model 7925 standalone unit is configured at the factory to operate at the CP side of an E1 HDSL connection. However, you can easily reconfigure a unit for use at the CO end, as would be necessary for the configurations in Figure 1-1. (Conversely, HotWire Model 7925 nest cards are preconfigured for CO operation.)

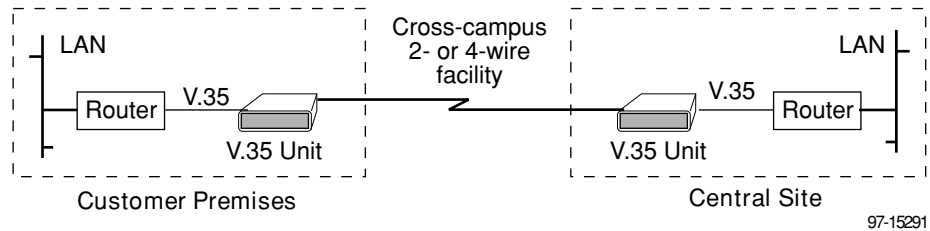
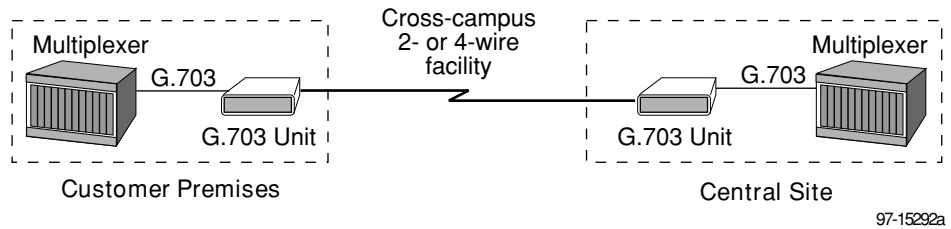

Figure 1-1. Campus Network Applications

HotWire Model 7925 standalone units are also ideal for delivering E1 services from a central site to the customer premises over long loop distances without repeaters.

Figure 1-2 shows a central office application with a HotWire Model 7900 Nest containing HotWire Model 7925 nest cards. The nest cards each terminate a single subscriber line in the CO. Each line is then converted to a G.703 interface for connection to other central office equipment, such as a digital cross-connect system (DCS).

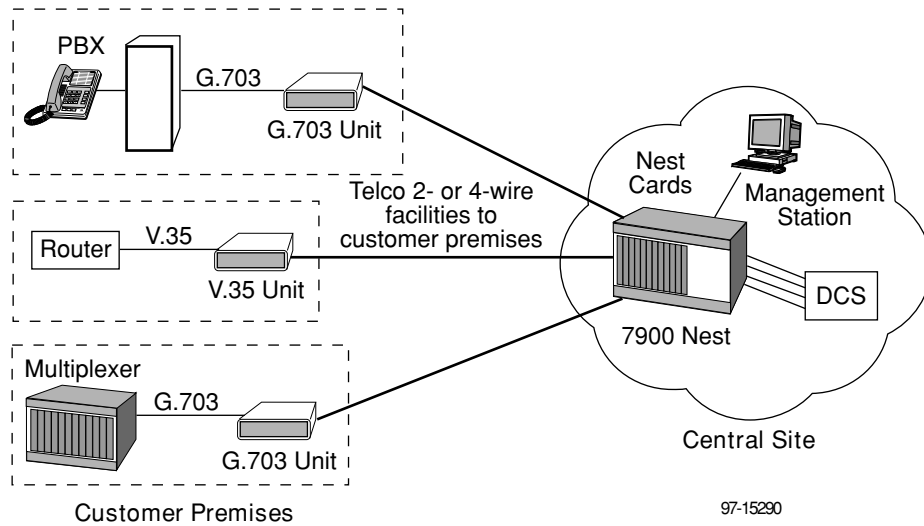

Figure 1-2. E1 Extension to Customer Premises

Cellular network providers must lease large numbers of E1 circuits in order to connect remote cell sites to mobile telephone switching offices (MTSOs). HotWire Model 7925 products provide an alternative to standard repeated E1 services. Figure 1-3 depicts a typical cellular network access application.

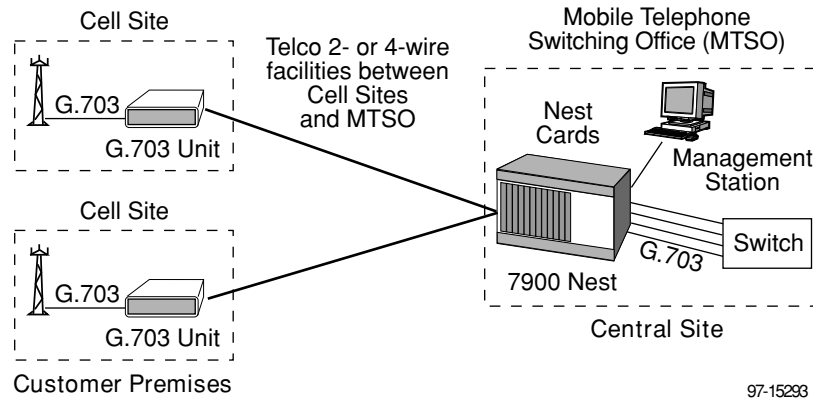

Figure 1-3. Cellular Network Access

User Interface Types

There are three types of user interfaces to the standalone units:

- VT100-compatible terminal interface (Terminal Mode, see [Chapter 3](#))
- Manual setting of switches and jumpers (Switchpack Mode, see [Chapter 3](#))
- Front Panel LED status indicators (see [Chapter 6](#))

Installing the Unit

2

Package Checklist for HotWire Model 7925-A1

Verify that your package contains the following:

- A HotWire Model 7925-A1 standalone unit
- VT100-compatible Terminal Cable
- A 14' twisted-pair network cable
- Warranty card
- 120 and 230 Vac models only:* Power cord with power transformer
- V.35-compatible units only:* a ferrite bead for RFI suppression

Connecting to the Network

► Procedure

1. Connect one end of the supplied 14' twisted-pair network cable into the rear panel HDSL jack. Connect the other end to your HDSL network interface.

NOTE:

Do *not* use a flat VF network cable, as this may severely degrade the performance of the termination unit. Use only a twisted-pair network cable.

2. *V.35-compatible units only:* Clamp the supplied ferrite bead around your V.35 cable, one inch from the end that plugs into the V.35 connector on the HotWire unit. This bead suppresses RF interference and is required to meet compliance standards.
3. Connect a V.35- or G.703-interface cable into the appropriate connector on the rear panel. Connect the other end to your V.35 or G.703 equipment.

Connecting Power to the Unit

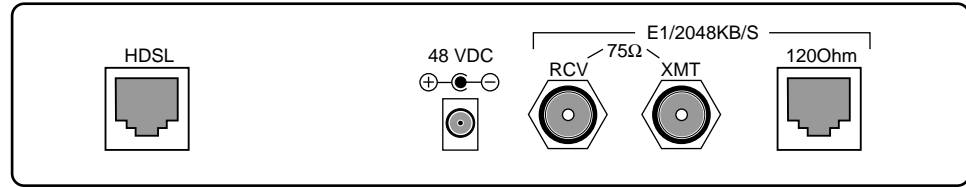

97-15262

G.703-Compatible HotWire 7925 – Rear Panel

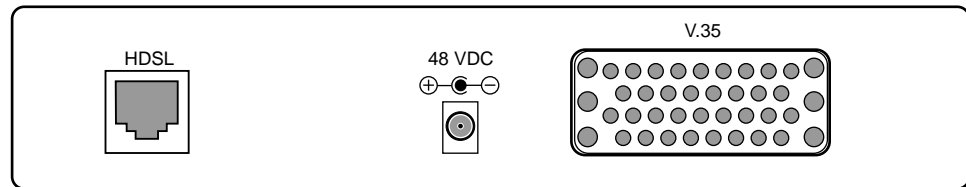

97-15264

V.35-Compatible HotWire 7925 – Rear Panel

As described in Chapter 1, there are several options for power cords, depending on your power source (120 Vac, 230 Vac, or –48 Vdc).

Your package may also include a country-specific adapter. To obtain information on the various power cord adapters available, refer to *Warranty, Sales, and Service Information* on page A at the beginning of this User's Guide.

If your package includes a 120 Vac or 230 Vac power cord with transformer: Plug the power transformer into an available 115/230 Vac power outlet, running the power lead to the unit housing. Neatly route the –48 Vdc cable to the housing, securing the cable to the wall and providing strain relief. Connect the power lead into the –48 Vdc plug on the rear panel.

If your package did not include a power cord: Model 7925-A1-50x units must be installed in a HotWire Model 7900 10-Slot Standalone Shelf. Refer to *Product-Related Documents* on page vi at the beginning of this User's Guide.

Using Terminal and Switchpack Modes

3

Choosing an Interface Mode

You can make configuration changes either through the system terminal menus (Terminal Mode) or by manually changing switches and jumpers on the board (Switchpack Mode). Terminal Mode is the default setting.

In Terminal Mode:

- You change configuration parameters by selecting menu options that appear on a VT100-compatible terminal attached to the front panel of the termination unit.
- The unit is configured at the factory for CP (customer premises) operation.
- If you change the line build-out, you need to move jumpers on the board.

In Switchpack Mode:

- All configuration parameters are taken from the current setting of the switchpacks and jumpers.
- You must ensure that the switchpacks and jumpers are set as desired. (They are not configured at the factory.)
- You can still display information about the unit from the terminal.
- Any changes you had made in Terminal Mode are lost when you change to Switchpack Mode.

Connecting to a System Terminal

An optional system maintenance terminal may be attached to your Model 7925 standalone termination unit through the modular jack on the front panel. You may have terminals attached to both endpoints (HTU-C and HTU-R).

The system terminal must be a VT100-compatible terminal or emulation software on a PC.

Connect the 9-pin end of the terminal cable into a COM port on your PC. Plug the other end into the modular jack on the front panel. If your PC requires a 25-pin connector to the COM port, see Appendix B, *Cable Pin Assignments*, for the correct cable pinouts.

Make sure the terminal parameters on your PC are set to:

- 9600 baud
- 8 bit
- no parity
- 1 stop bit
- no flow control

Press Return from your VT100-compatible terminal window to activate the main menu for the attached unit. The system runs diagnostics and status checks as it comes up. After a few moments, the Main Menu screen will appear on your VT100-compatible terminal. Menus are described in [Chapters 4 and 5](#) for the G.703 and V.35 units, respectively.

Switching Between Terminal and Switchpack Modes

The following procedure is used to change the operating mode of the unit to either Terminal Mode (the default setting) or Switchpack Mode. Refer to [Chapter 4](#) (for G.703-compatible units) or [Chapter 5](#) (for V.35-compatible units) for information on changing configuration options using either of these modes.

► Procedure

To change the mode:

1. Power down the unit and remove the enclosure cover, exposing the circuit board. Use electrostatic discharge (ESD) protection when handling the circuit board.
2. See Appendix C, *Switchpacks and Jumpers*, for jumper locations on your unit's board.
3. Locate the jumper header.
 - Use P11 for G.703-compatible units.
 - Use P8 for V.35-compatible units.
4. Place the jumper in the correct position for the desired mode.
 - Switchpack Mode is enabled by placing the jumper on Pins 2 and 3.
 - Terminal Mode is enabled by placing the jumper on Pins 1 and 2.
5. *If you are enabling Switchpack Mode:* You must set the switchpacks and jumpers to your desired configuration. Refer to *Switchpacks and Jumpers*, Appendix C.
6. Power up the board to reset and enable the new configuration.

Customizing G.703-Compatible Units

4

Accessing Configuration Options

This chapter provides instructions on how to change configuration options for HotWire 7925 standalone units that are G.703-compatible. [Chapter 5](#) provides similar information for V.35-compatible units.

Configuration option settings determine how the unit operates. You can change a unit's configuration options by:

- Selecting the Board Configuration branch of the Main Menu while in Terminal Mode.
- Changing switchpack and jumper settings on the board hardware while in Switchpack Mode.

The Main Menu for G.703-compatible units appears as follows:

```
Command→ G123

ATTX-CP E1 LOOP AB

E1 HDSL HTUR Main Menu

1) Board Status
2) Performance Monitor
3) Channel Blocking
4) Board Configuration
5) Board Reset
6) Local loopback
7) Remote loopback
8) HTUC Menu
?) Prints this Menu

Command→
```

- The “G123” code indicates the unit powered up successfully.
- Enter “?” to redisplay the menu.
- Option 3, Channel Blocking, is not available in this release.

This guide depicts the system terminal menus as they appear from a unit configured for use on the CP side of an HDSL connection. This is the default configuration for Model 7925-A1 units. The Main Menu for a unit configured for use on the CO side is identical, except that option 8 is HTUR Menu.

Making Changes from the Terminal Interface

The Board Configuration menu displays the current board software and hardware settings. It also allows you to change certain parameters on the board.

This function is affected by the status of the switchpack (DIP switch control) setting.

- When operating in Terminal Mode (the system default) you can make configuration changes through the terminal menus.
- When operating in Switchpack Mode, you can display configuration parameters using the terminal menus, but any configuration changes must be made using the switchpacks and jumpers on the board hardware. Refer to *Making Changes in Switchpack Mode* on page 4-6.

From the Main Menu, select option 4, Board Configuration.

```

Command→ 4

Board Configuration:

1) HDSL Card Type          - CP
   HDSL Rate Type         - E1
2) Loops Enabled          - Dual Loop (Loops A and B)
3) E1 Line Encode         - HDB3
4) Framing                - Framed
5) Line Build Out         - 75 ohm termination
   HDSL FW Rev            - 06
   AT+T FW Rev           - 1.17
   CP Serial #           - 086074

-----

1-5) Board Configuration
6) Switchpack Definitions
7) Line Build-Out Definitions
?) Prints Board Configuration and this menu
Q) Quit

Config→
    
```

Possible values for each parameter are listed in Table 4-1. See *Worksheets*, Appendix A, for help in selecting the appropriate configuration options for your application.

Table 4-1. G.703-Compatible Units Configuration Options

1) HDSL Card Type
Possible Settings: CP, CO Default Setting: CP
Indicates the placement of the unit in the network configuration. To toggle the card type, enter 1 at the Config prompt. CP – Unit is on the customer premises side of the HDSL connection. CO – Unit is on the central office (or central site) side of the HDSL connection.
2) Loops Enabled
Possible Settings: Loops A and B, Loop A Default Setting: Loops A and B
Specifies which loops on the HDSL line are to be used in the connection. To change the loops that are enabled, enter 2 at the Config prompt. The system then prompts you to specify either Dual (Loops A and B) or Single (Loop A only). Loops A and B – Loops A and B are enabled. Loop A – Only Loop A is enabled.
3) E1 Line Encode
Possible Settings: HDB3, AMI Default Setting: HDB3
Specifies the type of line encoding used to ensure one's density in the transmission signal. To toggle the encoding method, enter 3 at the Config prompt. HDB3 – High Density Binary 3. AMI – Alternate Mark Inversion.
4) Framing
Possible Settings: Framed, Unframed Default Setting: Framed
Specifies whether or not framing should be used. To toggle the framing method, enter 4 at the Config prompt. Framed – Framing is enabled. Unframed – Framing is disabled.
5) Line Build Out
Possible Settings: 75 ohm, 120 ohm Default Setting: 75 ohm
Specifies the transmit wave form compatible with the chosen termination impedance. To toggle the line build-out, enter 5 at the Config prompt. 75 ohm – Used with BNC coaxial cable connection on rear panel. 120 ohm – Used with modular cable connection on rear panel. You must also change the position of jumpers C31, C33, P6, and P7 on the board. Refer to <i>Changing the Line Build-Out</i> , on page 4-5.

You must reset the board for changes to the card type or loops enabled (options 1 or 2) parameters to take effect. A system message is displayed on the terminal to remind you to reset the board. To reset the board, use option 5 from the Main Menu. (The board may also be reset by cycling the power on the board.) All configuration settings are stored in nonvolatile memory.

The HDSL rate type, firmware revision numbers, and the serial number displayed on the Board Configuration screen cannot be changed.

Options 6 and 7 (Switchpack and Line Build-Out Definitions) on the Config menu display the switchpack and jumper positions used when changing configuration changes manually.

Displaying Switchpack Definitions

Enter **6** at the Config prompt to display the switchpack definitions. Switchpack definitions are also listed in *Switchpacks and Jumpers*, Appendix C.

```
Config→ 6

Switch pack definition:

1 - CO/CP                OFF=CP, ON=CO
2 - HDB3                 OFF/ON
3 - Double/Single Loop Mode  OFF=Double, ON=Single
4 - Not Used
5 - Line Build Out       OFF=75 ohm, ON=120 ohm
6 - Not Used
7 - Not Used
8 - Framed/Unframed     OFF=Unframed, ON=Framed

Config→
```

Displaying Line Build-Out Definitions

Enter **7** at the Config prompt to display the switchpack and board settings for line build-out. This information is useful if you need to change the line build-out parameter manually. Refer to *Changing the Line Build-Out* on page 4-5 for more information.

Line build-out selects a transmit wave form compatible with the chosen termination impedance (75 ohm or 120 ohm).

```

Config→ 7

***** SWITCHPACK AND BOARD SETTINGS FOR LINE BUILD OUT *****
Switchpack Setting          Jumpers P6 and P7 on Stand Alone
-----                    Jumpers P4 and P5 on Shelf Mount
Position #5  OFF=75 ohm
              ON=120 ohm
              1 & 2 for 120 ohm lines
              2 & 3 for 75 ohm lines

Command→

```

Changing the Line Build-Out

To change the line build-out (LBO), you must move the position of four jumpers on the board in addition to changing the Line Build-Out configuration option using either Terminal or Switchpack Mode.

► Procedure

To open the unit and change the LBO:

1. *If you are using Terminal Mode:* Select option 4 (Board Configuration) from the Main Menu, then select option 5 from the Config prompt to toggle the LBO to the desired value.
2. Power down the unit and remove the enclosure cover, exposing the circuit board. Use electrostatic discharge (ESD) protection when handling the circuit board.
3. Refer to *Switchpacks and Jumpers*, Appendix C, for switchpack and jumper locations.
4. Locate the jumper headers labeled P6 and P7.
 - For 75 ohm LBO, position both jumpers on Pins 2 and 3.
 - For 120 ohm LBO, position both jumpers on Pins 1 and 2.

5. Locate the jumper headers labeled C31 and C33. (These may also be labeled P13 and P14, depending on when your board was manufactured.)
 - For 75 ohm LBO, position both jumpers on Pins 1 and 2.
 - For 120 ohm LBO, position both jumpers on Pins 2 and 3.
6. *If you are using Switchpack Mode:* Set position 5 on switchpack S1 to either OFF for 75 ohm LBO or ON for 120 ohm LBO.
7. Replace the enclosure cover and power up the board to reset and enable the new line build-out setting.

Making Changes in Switchpack Mode

When operating in Switchpack Mode, you can change configuration options by moving switches and jumpers on the board hardware. To enable Switchpack Mode, refer to *Switching Between Terminal and Switchpack Modes* in Chapter 3.

► Procedure

To open the unit and make changes in Switchpack Mode:

1. Power down the unit and remove the enclosure cover, exposing the circuit board. Use electrostatic discharge (ESD) protection when handling the circuit board.
2. Find the switchpack or jumper header for the configuration options you wish to change. Switchpack and jumper positions are defined in *Switchpacks and Jumpers*, Appendix C.
3. Place the switchpack or jumper in the correct position for each desired configuration option. For example, to change a unit's card type from CP to CO, move DIP switch 1 on switchpack S1 to the ON position.
4. Make sure that DIP switches 4, 6, and 7 are in the OFF position.
5. Replace the enclosure cover and power up the board to reset and enable the new configuration.

Customizing V.35-Compatible Units

5

Accessing Configuration Options

This chapter provides instructions on how to change configuration options for HotWire 7925 standalone models that are V.35-compatible. [Chapter 4](#) provides similar information for G.703-compatible units.

Configuration option settings determine how the unit operates. You can change a unit's configuration options by:

- Selecting the Board Configuration branch of the Main Menu while in Terminal Mode.
- Changing switchpack and jumper settings on the board hardware while in Switchpack Mode.

The Main Menu for V.35-compatible units appears as follows:

```
Command→ G123

ATTX-CP E1 LOOP AB

V.35 E1 HDSL HTUR Main Menu

1) Board Status
2) Performance Monitor
3) Board Configuration
4) Board Reset
5) Local Loopback
6) Remote Loopback
7) HTUC Menu
?) Prints this Menu

Command→
```

- The “G123” code indicates that the unit powered up successfully.
- Enter “?” to redisplay the menu.

This guide depicts the system terminal menus as they appear from a unit configured for use on the CP side of an HDSL connection. This is the default configuration for Model 7925 units. The Main Menu for a unit configured for use on the CO side is identical, except that option 7 is HTUR Menu.

Making Changes from the Terminal Interface

The Board Configuration menu displays the current board software and hardware settings. It also allows you to change certain parameters on the board.

This function is affected by the status of the switchpack (DIP switch control) setting.

- When operating in Terminal Mode (the system default) you can make configuration changes through the terminal menus.
- When operating in Switchpack Mode, you can display configuration parameters using the terminal menus, but any configuration changes must be made using the switchpacks and jumpers on the board hardware. Refer to *Making Changes in Switchpack Mode* on page 5-4.

From the Main Menu, select option 3, Board Configuration.

```

Command→ 3

Board Configuration:

  1) HDSL Card Type           - CP
     HDSL Interface/Rate     - V.35 E1
  2) Loops Enabled           - Dual Loop (Loops A and B)
  3) Payload Rate            - 2048 Kbps (32x64)
  4) Transmit Timing         - loop
     HDSL FW Rev              - 03
     AT+T FW Rev              - 1.17
     CP Serial #              - 85649

-----

1-4) Board Configuration
5)   Switchpack Definitions
?)   Prints Board Configuration and this menu
Q)   Quit

Config→
    
```

Possible values for each parameter are listed in Table 5-1. See *Worksheets*, Appendix A, for help in selecting the appropriate configuration options for your application.

Table 5-1. V.35-Compatible Units Configuration Options

1) HDSL Card Type										
Possible Settings: CP, CO Default Setting: CP										
Indicates the placement of the unit in the network configuration. To toggle the card type, enter 1 at the Config prompt. CP – Unit is on the customer premises side of the HDSL connection. CO – Unit is on the central office (or central site) side of the HDSL connection.										
2) Loops Enabled										
Possible Settings: Loops A and B, Loop A Default Setting: Loops A and B										
Specifies which loops on the HDSL line are to be used in the connection. To change the loops that are enabled, enter 2 at the Config prompt. The system then prompts you to specify either Dual (Loops A and B) or Single (Loop A only). Loops A and B – Loops A and B are enabled. Loop A – Only Loop A is enabled.										
3) Payload Rate										
Possible Settings: 1 through 9 (for 64 through 2048 kbps) Default Setting: 9 (2048 kbps)										
Specifies the desired payload rate. Single loop operation will accommodate up to 1024 Kbps (rates 1 x 64 through 16 x 64). The 32 x 64 (2048 Kbps) setting requires dual loop operation.										
<table> <tr> <td>1 – 1 x 64 (64 kbps)</td> <td>6 – 8 x 64 (512 kbps)</td> </tr> <tr> <td>2 – 2 x 64 (128 kbps)</td> <td>7 – 12 x 64 (768 kbps)</td> </tr> <tr> <td>3 – 3 x 64 (192 kbps)</td> <td>8 – 16 x 64 (1024 kbps)</td> </tr> <tr> <td>4 – 4 x 64 (256 kbps)</td> <td>9 – 32 x 64 (2048 kbps)</td> </tr> <tr> <td>5 – 6 x 64 (384 kbps)</td> <td></td> </tr> </table>	1 – 1 x 64 (64 kbps)	6 – 8 x 64 (512 kbps)	2 – 2 x 64 (128 kbps)	7 – 12 x 64 (768 kbps)	3 – 3 x 64 (192 kbps)	8 – 16 x 64 (1024 kbps)	4 – 4 x 64 (256 kbps)	9 – 32 x 64 (2048 kbps)	5 – 6 x 64 (384 kbps)	
1 – 1 x 64 (64 kbps)	6 – 8 x 64 (512 kbps)									
2 – 2 x 64 (128 kbps)	7 – 12 x 64 (768 kbps)									
3 – 3 x 64 (192 kbps)	8 – 16 x 64 (1024 kbps)									
4 – 4 x 64 (256 kbps)	9 – 32 x 64 (2048 kbps)									
5 – 6 x 64 (384 kbps)										
4) Transmit Timing										
Possible Settings: External, Internal, Loop Default Setting: Loop										
Determines the clock source for transmitted data. To toggle the timing source, enter 4 at the Config prompt. External – The V.35 interface is used as the primary clock source. Internal – The internal clock is used as the primary clock source. Loop – The HDSL line is used as the primary clock source.										

For example, to change the card type, enter **1** at the Config prompt. This toggles the parameter from CP to CO. Entering **1** again changes it back to CP.

You must reset the board for changes to the card type or loops enabled (options 1 or 2) parameters to take effect. A system message is displayed on the terminal to remind you to reset the board. To reset the board, use option 4 from the Main Menu. (The board may also be reset by cycling the power on the board.) All configuration settings are stored in nonvolatile memory.

The HDSL rate type, firmware revision numbers, and serial number displayed on the Board Configuration screen cannot be changed.

Option 5 (Switchpack Definitions) on the Config menu is used to display the switchpack and jumper positions used when making configuration changes manually. This menu option is described in *Displaying Switchpack Definitions* on page 5-5.

Making Changes in Switchpack Mode

When operating in Switchpack Mode, you can change configuration options by moving switches and jumpers on the board hardware. To enable Switchpack Mode, refer to *Switching Between Terminal and Switchpack Modes* in Chapter 3.

► Procedure

To open the unit and make changes in Switchpack Mode:

1. Power down the unit and remove the enclosure cover, exposing the circuit board. Use electrostatic discharge (ESD) protection when handling the circuit board.
2. Find the switchpack or jumper header for the configuration options you wish to change. Switchpack and jumper positions are defined in *Switchpacks and Jumpers*, Appendix C.
3. Place the switchpack or jumper in the correct position for each desired configuration option. For example, to change a unit's card type from CP to CO, move DIP switch 1 on switchpack 1 to the ON position.
4. Replace the enclosure cover and power up the board to reset and enable the new configuration.

Displaying Switchpack Definitions

Enter **5** at the Config prompt to display the switchpack definitions. Switchpack definitions are also listed in *Switchpacks and Jumpers*, Appendix C.

```
Config→ 5

Switch pack 1 definition:
  1 - CO/CP                                OFF=CP, ON=CO
  2 - Double/Single Loop Mode             OFF=Double, ON=Single
  3 - Not Used
  4,5- 00,11=Internal Timing              OFF=0, ON=1
        01=External Timing, 10=Loop Timing
  6-8- Not Used

Switch pack 2 definition:
  1 - 64 Kbps (1x64)                       OFF=0, ON=1
  2 - 128 Kbps (2x64)                      OFF=0, ON=1
  3 - 192 Kbps (3x64)                      OFF=0, ON=1
  4 - 256 Kbps (4x64)                      OFF=0, ON=1
  5 - 384 Kbps (6x64)                      OFF=0, ON=1
  6 - 512 Kbps (8x64)                      OFF=0, ON=1
  7 - 768 Kbps (12x64)                     OFF=0, ON=1
  8 - 1024 Kbps (16x64)                    OFF=0, ON=1
  All switches off = 2048 Kbps (32x64)

Config→
```

Monitoring the Unit

6

What to Monitor

This chapter presents information on how to access and monitor status and performance statistics for the unit and its network connection. You can monitor operations by viewing:

- Board Status option from the Main Menu
- Performance Monitor option from the Main Menu
- Board Status and Performance Monitor options from the HTUC (or HTUR) Menu (for displaying information about the unit on the other end of the connection)
- Front Panel LEDs

Board Status

Board Status option from the Main Menu displays HDSL circuit operational status. Enter **1** at the Command prompt to display board status.

```
Command→ 1

E1 STATUS:      Network is UP

LOOPBACK STATUS: OFF

HDSL STATUS:    LOOP A is UP, LOOP B is UP

S/N RATIO:      Loop A = 44.0 dB, Loop B = 43.5 dB

Command→
```

Board Status for G.703-Compatible Unit

```
Command→ 1

DTR:           ACTIVE
DSR:           ACTIVE

LOOPBACK STATUS: OFF

HDSL STATUS:    LOOP A is UP, LOOP B is UP

S/N RATIO:      Loop A = 44.0 dB, Loop B = 43.5 dB.

Command→
```

Board Status for V.35-Compatible Unit

- E1 status displays one of the following: Network is Up, Receive Carrier Loss, Receive Remote Alarm, or Receive Unframed All 1's.
- DTR and DSR are either active or inactive. DSR becomes active in response to DTR (with HDSL loops up and data transmission possible).
- Loopback status is either ON or OFF.
- HDSL status displays whether each loop is up, down, or disabled.
- Signal-to-Noise (S/N) ratios do not display if loops are down or disabled.

Performance Statistics

Performance monitoring allows more detailed observations of error conditions detected on the circuits. The Performance Monitor menu options provide statistics on errors received and recorded, in defined time periods from the previous minute to the previous 24 hours, plus a running total. These statistics can be cleared and restarted at any time.

Performance statistics update every second.

Accumulated performance statistics may be cleared and restarted by selecting option 7 on the performance menu.

NOTE:

There is no verification message displayed before statistics are deleted. Be sure you want to clear all statistics before pressing 7.

Enter **2** at the Command prompt to enter the Performance Monitor menu.

```
Command→ 2

Time Since Board Power-Up or Reset: 17:31:51
1 - 1 minute stats.
2 - 15 minute stats.
3 - 1 hour stats.
4 - 12 hour stats.
5 - 24 hour stats.
6 - Running total.
7 - Clear Statistics.
Q - Quit

stats→
```

Select a time frame from the above list to display statistics for a specified time period.

```
stats→ 1

Current 1 minute:
HDSL Errors:           E1 Errors:
FAW LoopA - 0          CV - 0
FAW LoopB - 0          FAS - 0
CRC LoopA - 0
CRC LoopB - 0
FEBE LoopA - 0
FEBE LoopB - 0

Previous 1 minute:
HDSL Errors:
FAW LoopA - 0          CV - 0
FAW LoopB - 0          FAS - 0
CRC LoopA - 0
CRC LoopB - 0
FEBE LoopA - 0
FEBE LoopB - 0

stats→
```

Performance Statistics for G.703-Compatible Unit

```
stats→ 1

Current 1 minute:
HDSL Errors:
FAW LoopA    0
FAW LoopB    0
CRC LoopA    0
CRC LoopB    0
FEBE LoopA   0
FEBE LoopB   0

Previous 1 minute
HDSL Errors:
FAW LoopA    0
FAW LoopB    0
CRC LoopA    0
CRC LoopB    0
FEBE LoopA   0
FEBE LoopB   0

stats→
```

Performance Statistics for V.35-Compatible Unit

E1 errors are displayed for G.703-compatible units only when framing is enabled. The type of statistics displayed under the E1 Errors column depends on which type of line encoding is selected (AMI or HDB3). Refer to the *Glossary* for definitions of the types of errors reported.

Remote Unit Information

The same type of information provided for the locally-attached unit (CP or CO) can also be displayed (but not changed) for the unit on the other side of the connection (CO or CP).

From a terminal attached to a CP unit, you can display information about the CO unit by using the HTUC menu options. Similarly, from a terminal attached to a CO unit, the HTUR menu allows you to display information about the CP unit.

To access the HTUC (or HTUR) menu:

- If you have a G.703-compatible unit, enter **8** at the Command prompt.
- If you have a V.35-compatible unit, enter **7** at the Command prompt.

```
***** HTUC Menu *****
1) Board Status
2) Performance Monitor
3) Board Configuration
4) Line Build Out Configuration Help
?) Prints this menu
Q) Quit

HTUC Command→
```

Front Panel LEDs

G.703-Compatible Unit

Upon power up, the first three LEDs blink in sequence, indicating a successful start configuration. The green PWR LED lights whenever power is applied to the board. Loop LEDs blink until the loop has been synchronized and then remain off.

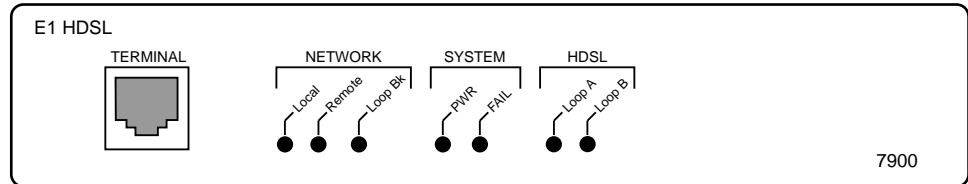

97-15255

LED	Meaning
Local	The local E1 interface has a loss of signal.
Remote	The remote E1 interface has a loss of signal.
Loop Bk	A bilateral loopback has been initiated for testing the equipment connected to this unit.
PWR	Power is applied to the unit.
FAIL	The processor has halted and repairs are required.
Loop A	A failure in HDSL Loop A. (The LED will blink at board power up until the loop has been synchronized.)
Loop B	A failure in HDSL Loop B or the loop has been disabled. (The LED will blink at board power up until the loop has been synchronized.)

V.35-Compatible Unit

The green PWR LED lights whenever power is applied to the board. Loop LEDs blink until the loop has been synchronized and then remain off.

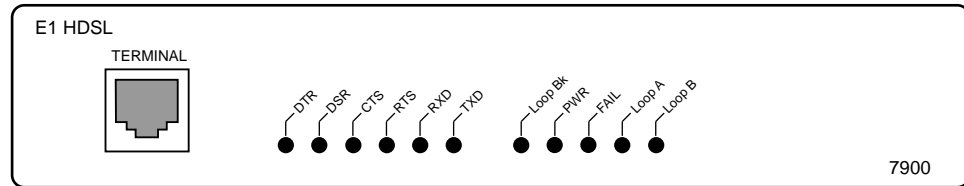

97-15263

LED	Meaning
Loop Bk	A bilateral loopback has been initiated for testing the equipment connected to this unit.
PWR	Power is applied to the unit.
FAIL	The processor has halted and repairs are required.
Loop A	A failure in HDSL Loop A. (The LED will blink at board power up until the loop has been synchronized.)
Loop B	A failure in HDSL Loop B or the loop has been disabled. (The LED will blink at board power up until the loop has been synchronized.)

Testing

7

Detecting a Problem

The unit can detect and report problem conditions and perform diagnostic tests. The unit offers a number of indicators to alert you to possible problems, as described in *Monitoring the Unit*, Chapter 6:

- Front Panel LEDs
- Board Status and performance statistics
- Remote unit board status and performance statistics

Understanding Loopback Tests

Loopback is a diagnostic function that enables a technician to isolate equipment on the HDSL circuit to determine where on the circuit trouble may be occurring. Loopback takes the system off-line. Data received from E1 or V.35 application equipment is looped back, as depicted in Figures 7-1 through 7-3.

“Local” and “remote” refer to the point at which the data is looped back. In a local loopback the data is reflected back by the local unit (CO or CP, depending on where the command is initiated). In a remote loopback, the data is passed on to the remote-end unit and then reflected back.

Loopback tests may only be initiated through the system terminal.

Loopback tests may be initiated from either the CO or CP side of the HDSL connection.

Local Loopbacks

When local loopback is enabled the red Loop Bk LED on the front panel of the initiating unit (CO or CP) lights up and remains lit until the loopback is disabled.

Figure 7-1 illustrates local loopback from a CO unit in a connection between two units of the same compatibility (either two G.703-compatible units or two V.35-compatible units).

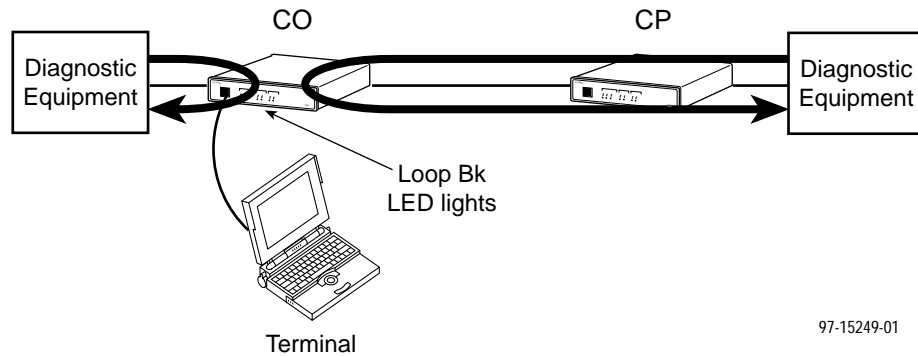

Figure 7-1. Local Loopback from CO End, Two Like Units (both G.703 or both V.35)

Figure 7-2 illustrates local loopback in the same connection as in Figure 7-1, but the loopback is initiated from the CP end.

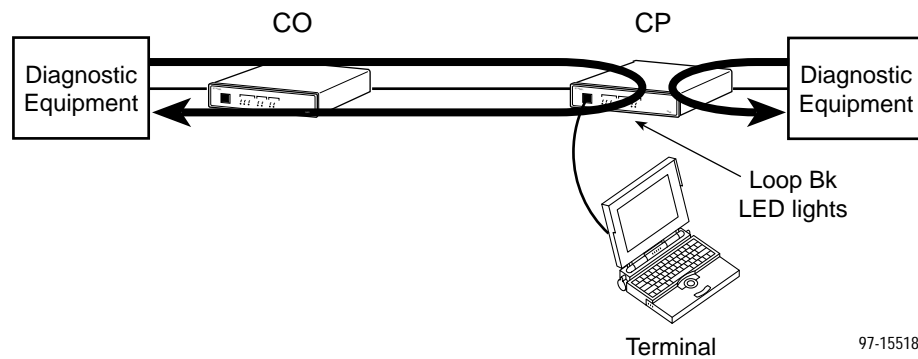
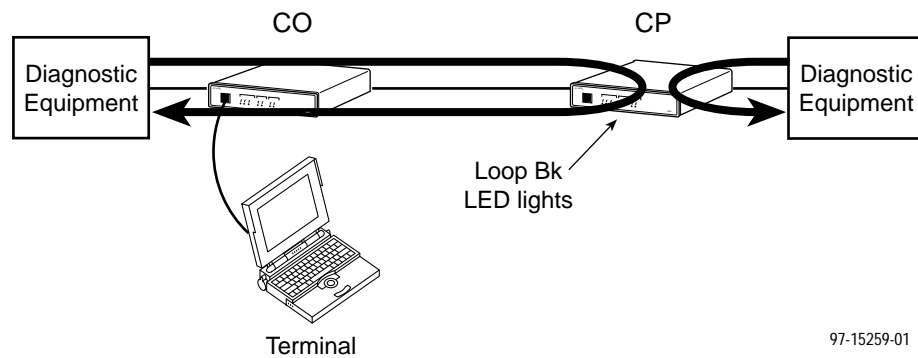

Figure 7-2. Local Loopback from CP End, Two Like Units (both G.703 or both V.35)

Remote Loopbacks

When remote loopback is enabled the red Loop Bk LED on the front panel of the remote-end unit (CO or CP) lights up and remains lit until the loopback is disabled. The loopback LED on the initiating unit does not light.

Figure 7-3 illustrates remote loopback from a CO unit in a connection between two units of the same compatibility (either two G.703-compatible units or two V.35-compatible units).



97-15259-01

Figure 7-3. Remote Loopback from CO End, Two Like Units (both G.703 or V.35)

Starting and Ending Loopbacks

To start or stop a local loopback test:

- If you have a G.703-compatible unit, enter **6** at the Command prompt.
- If you have a V.35-compatible unit, enter **5** at the Command prompt.

```
Command→ 6 (5)
Local Loopback is Enabled!

Command→ 6 (5)
Local Loopback is Disabled!
```

To start or stop a remote loopback test:

- If you have a G.703-compatible unit, enter **7** at the Command prompt.
- If you have a V.35-compatible unit, enter **6** at the Command prompt.

```
Command→ 7 (6)
Remote Loopback is Enabled!

Command→ 7 (6)
Remote Loopback is Disabled!
```

Resetting the Unit

To reset the board (equivalent to cycling the power):

- If you have a G.703-compatible unit, enter **5** at the Command prompt.
- If you have a V.35-compatible unit, enter **4** at the Command prompt.

```
Command→ 5 (4)
```

```
Reset will bring the loops down. Are you sure? (y/n)
```

```
Command→
```

If “y” is selected, the Main Menu redisplay, the loops go down, and the FAIL (reset) LED lights.

Pressing any key other than “y” is interpreted as an “n”.

Worksheets

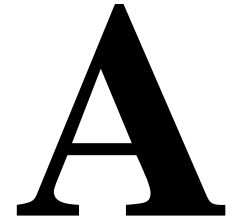

Overview

The worksheets in this appendix show the correct configuration settings based on the types of units (G.703-compatible or V.35-compatible) on either end of the HDSL connection. There are three combinations of the two types of units:

- G.703-compatible units on both ends
- V.35-compatible units on both ends
- V.35-compatible unit on the CP end, G.703-compatible unit on the CO end

G.703-to-G.703 Configuration

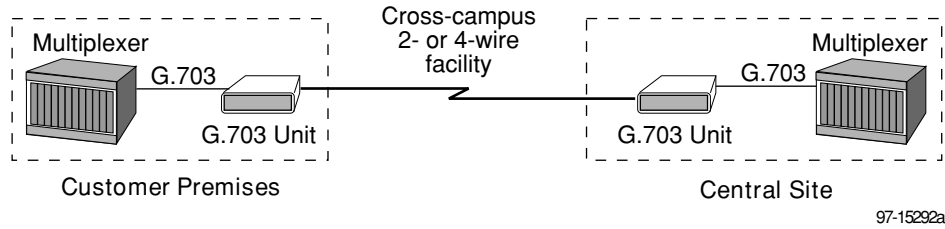

To connect two G.703-compatible units, configure the units as follows. Terminal mode factory defaults are in bold. (For Switchpack mode defaults, see Appendix C.)

Configuration Option	G.703-Compatible Unit (Customer Premises)	G.703-Compatible Unit (Central Site)
Card Type	CP (default)	CO
Loops Enabled	Dual (Loops A & B) or Single (Loop A)	Must be same as CP side
E1 Line Encode	HDB3 or AMI	Must be same as CP side
Framing	Framed or Unframed (If payload rate is less than 2048 kbps, select Framed; else select either option)	Must be same as CP side
Line Build-Out ¹	75 ohm or 120 ohm	75 ohm or 120 ohm (does not need to be the same as the CP side)
¹ Jumpers C31, C33, P6, and P7 must be manually changed to match the configured line build-out rate. See <i>Changing the Line Build-Out</i> in Chapter 4 for instructions.		

V.35-to-V.35 Configuration

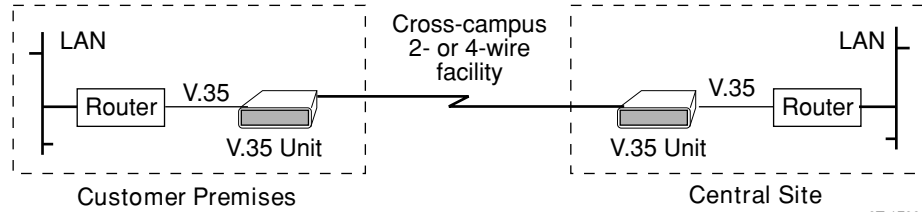

To connect two V.35-compatible units, configure the units as follows. Terminal mode factory defaults are in bold. (For Switchpack mode defaults, see Appendix C.)

Configuration Option	V.35-Compatible Unit (Customer Premises)	V.35-Compatible Unit (Central Site)
Card Type	CP (Default)	CO
Loops Enabled	Dual (Loops A & B) or Single (Loop A)	Must be same as CP side
Payload Rate	1 – 9 (64 – 2048 Kbps). If only Loop A is enabled, rate can only go up to 1024 Kbps, option 8.	Must be same as CP side
Transmit Timing	Loop	If clock is supplied by the CO's V.35 application equipment, use External, else use Internal.

G.703-to-V.35 Configuration

To connect a V.35-compatible unit on the CP side and a G.703-compatible unit on the CO side, configure the units as follows. Terminal mode factory defaults are in bold. (For Switchpack mode defaults, see Appendix C.)

Configuration Option	V.35-Compatible Unit (Customer Premises)	G.703-Compatible Unit (Central Site)
Card Type	CP	CO
Loops Enabled	Dual (Loops A & B) or Single (Loop A)	Must be same as CP side
Payload Rate	1 – 9 (64 – 2048 Kbps) Option 9 (2048 kbps) is only available if Loops A & B are enabled.	N/A
Transmit Timing	Loop	N/A
Framing	N/A	If the payload rate is 2048 Kbps, use Unframed. If the payload rate is less than 2048 Kbps, use Framed.
E1 Line Encode	N/A	HDB3 or AMI
Line Build-Out ¹	N/A	75 ohm or 120 ohm
¹ Jumpers C31, C33, P6, and P7 must be manually changed to match the configured line build-out rate. See <i>Changing the Line Build-Out</i> in Chapter 4 for instructions.		

When the V.35 payload rate is set for less than 2048 Kbps, that payload rate determines which E1 DS0s are used, as follows:

V.35 Payload Rate	G.703 E1 DS0s Used
1 (64 Kbps)	1
2 (128 Kbps)	1, 3
3 (192 Kbps)	1, 3, 5
4 (256 Kbps)	1, 3, 5, 7
5 (384 Kbps)	1, 3, 5, 7, 9, 11
6 (512 Kbps)	1, 3, 5, 7, 9, 11, 13, 15
7 (768 Kbps)	1, 3, 5, 7, 9, 11, 13, 15, 16, 18, 20, 22
8 (1024 Kbps)	1, 3, 5, 7, 9, 11, 13, 15, 16, 18, 20, 22, 24, 26, 28, 30

G.703-Compatible Units Configuration Worksheet

Board Configuration	
Configuration Option	Settings <i>Default in Bold</i>
HDSL Card Type	CP, CO
Loops Enabled	Loops A and B , Loop A
E1 Line Encode	HDB3 , AMI
Framing	Framed , Unframed
Line Build Out	75 ohm , 120 ohm

V.35-Compatible Units Configuration Worksheet

Board Configuration	
Configuration Option	Settings <i>Default in Bold</i>
HDSL Card Type	CP, CO
Loops Enabled	Loops A and B , Loop A
Payload Rate	9 , 1–9
Transmit Timing	External, Internal, Loop

Cable Pin Assignments

B

Terminal Connection Cable Pin Assignments

This section defines the pin assignments for the terminal cable from the front panel modular jack to your PC's COM port.

If your PC's COM port requires a 9-pin D-shell connector, the cable must use the following pin assignments.

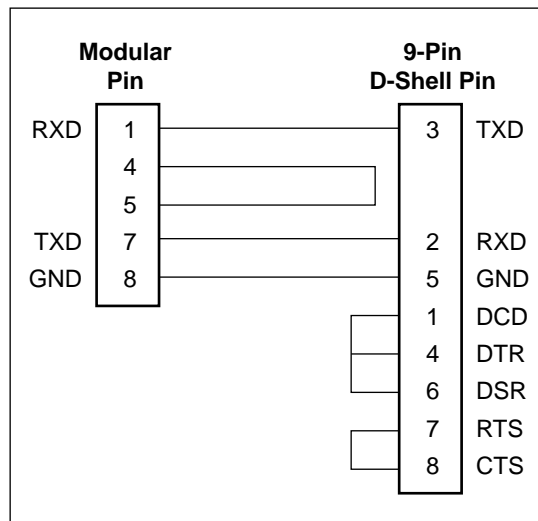

97-15268-02

If your PC's COM port requires a 25-pin D-shell connector, the cable must use the following pin assignments.

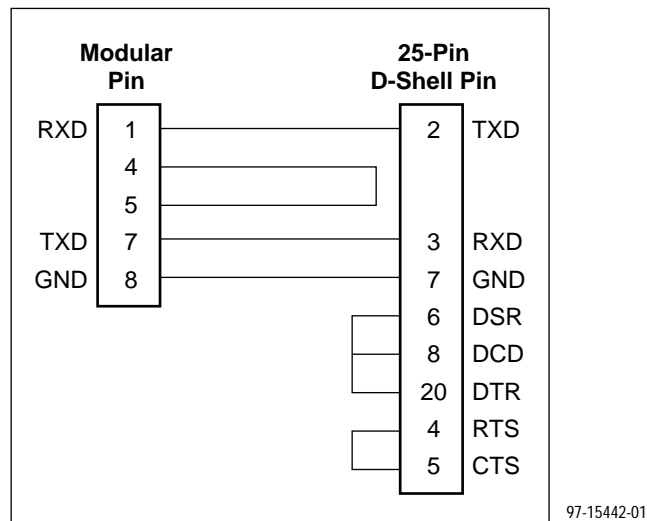

HDSL Loop Connection Cable Pin Assignments

The HDSL modular connector that plugs into the rear panel of the unit has the following pin assignments.

Pin	Signal
1	Loop A Tip
2	Loop A Ring
3	Loop B Tip
4	Loop B Ring
5 – 8	unused

NOTE:

Pin 1 is on the left when viewing the jack from its inserted position.

E1 Network 120 Ohm Connection Cable Pin Assignments

The 120 ohm modular connector that plugs into the rear panel of G.703-compatible units has the following pin assignments.

Pin	Signal
1	Tx Ring
2	Tx Tip
3	unused
4	Rx Ring
5	Rx Tip
6 – 8	unused

NOTE:

Pin 1 is on the left when viewing the jack from its inserted position.

V.35 Connection Cable Pin Assignments

The connector that plugs into the rear panel of V.35-compatible units has the following pin assignments.

CCITT Code	Pin	Name	Direction DCE DTE	Function	Description
101	A	PG		Protective Ground	Machine ground
102	B	SG		Signal Ground	Ground reference for all circuits
105	C	RTS	←	Request to Send	DTE has message to send
106	D	CTS	→	Clear to Send	DCE is ready to accept and transmit DTE data
107	E	DSR	→	Data Set Ready	DCE is ready to operate
109	F	RLSD	→	Data Channel Received Line Signal Detector	DCE is receiving a carrier signal
108	H	DTR	←	Data Receiver Ready	DTE is ready to operate
141	L	LL	←	Local Loopback	Local loopback
140	N	RDL	←	Loopback/ Maintenance	Remote loopback
103	P	TXD	←	Transmit Data (A)	Data generated by DTE
104	R/D	RXD	→	Received Data (A)	Data received by DTE
103	S	TXD	←	Transmitted Data (B)	Data generated by DTE
104	R	RXD	→	Received Data (B)	Data received by DTE
113	U	EXT CLK	←	Transmitter Signal Element Timing (A)	To help detect center of signaling element on BA
115	V	RSET	→	Receiver Signal Element Timing (A)	To help detect center of signaling element on BB
113	W	EXT CLK	←	Transmitter Signal Element Timing (B)	To help detect center of signaling element on BA
115	X	RSET	→	Receiver Signal Element Timing (B)	To help detect center of signaling element on BB
114	Y	TSET	→	Transmit Signal Element Timing (A)	To help detect center of signaling element on BA
114	a	TSET	→	Transmit Signal Element Timing (B)	To help detect center of signaling element on BB
142	n	TST	→	Test Indicator	Reserved for test

Switchpacks and Jumpers

C

G.703-Compatible Units

Use Figure C-1 to assist you in locating the switchpacks and jumpers on the board.

The jumpers and switchpack detailed in Figure C-1 are used to change configuration options. All other jumpers (listed below) should always be left as positioned at the factory.

Jumper	Pins (Factory-Setting)
P1	2-3
P3	No Jumper
P8	2-3
P9	2-3
P10	1-2
P12	1-2

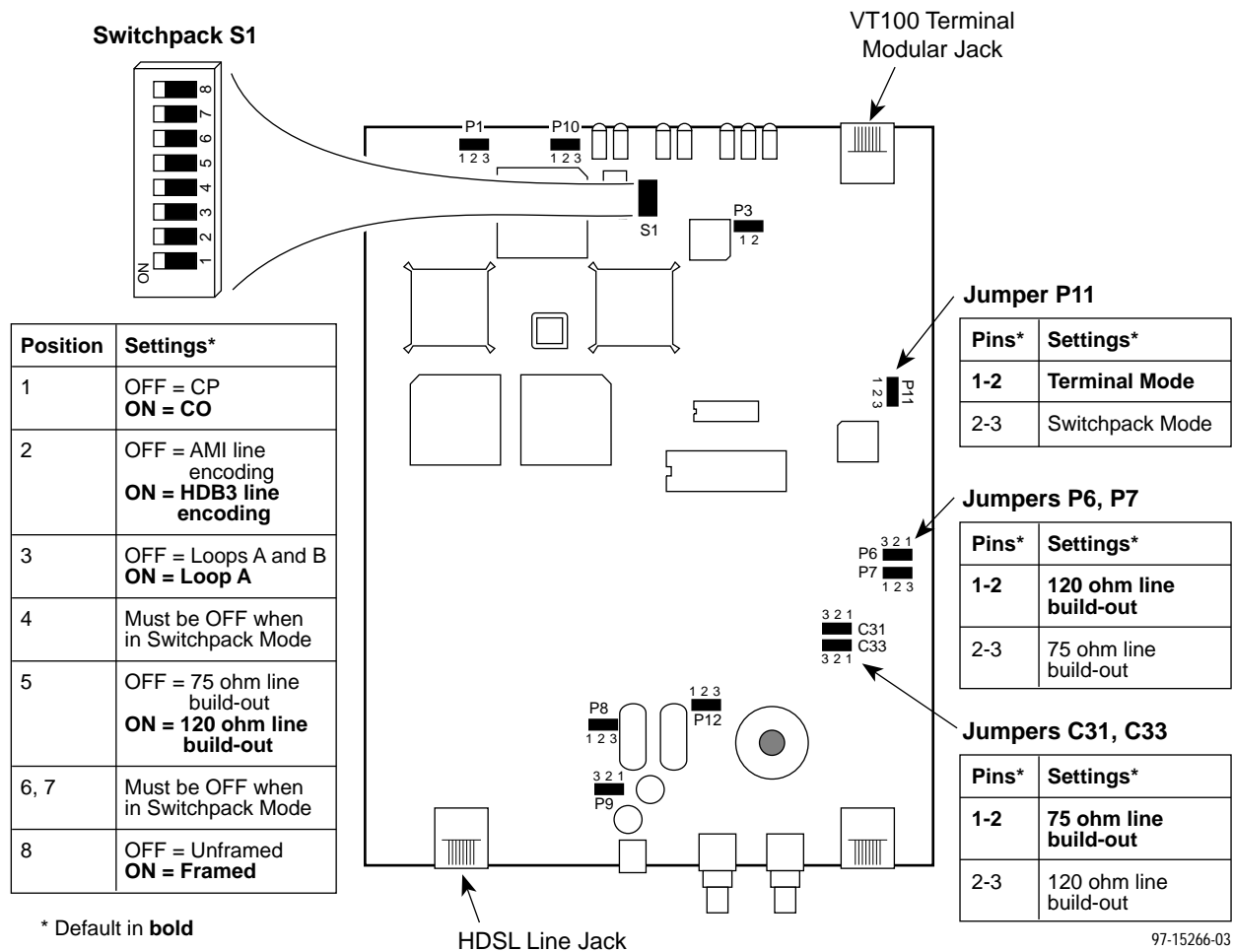

Figure C-1. G.703-Compatible Unit Switchpack and Jumper Locations

- Positions 4, 6, 7 on S1 must be OFF when in Switchpack Mode.
- P6 and P7 must be placed in the same position (both 1-2 or both 2-3).
- C33 and C31 must be placed in the same position (both 1-2 or both 2-3).
- C33 and C31 may also be labeled P13 and P14.
- Pin 1 on most jumpers is labeled on the board. However, Pin 1 on jumpers C31 and C33 is the pin closest to the board edge.
- The ON position is labeled on the switchpack.

V.35-Compatible Units

Use Figure C-2 to assist you in locating the switchpacks and jumpers on the board.

The jumpers and switchpacks detailed in Figure C-2 are used to change configuration options. All other jumpers (listed below) should always be left as positioned at the factory.

Jumper	Pins (Factory-Setting)
P1	2-3
P2	1-2
P4	2-3
P5	No Jumper
P9	2-3
P10	2-3
P11	1-2

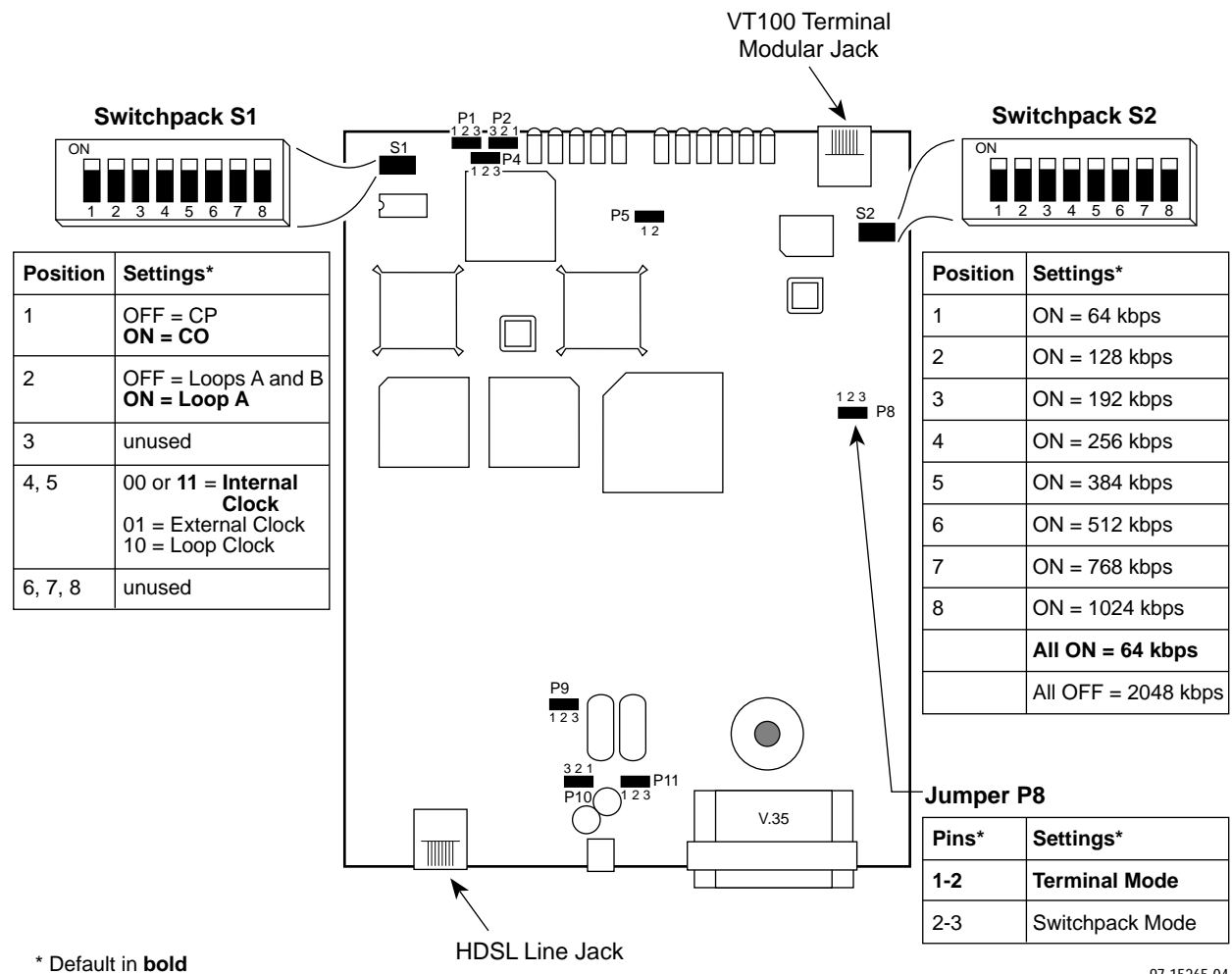

Figure C-2. V.35-Compatible Unit Switchpack and Jumper Locations

- Positions 4 and 5 on Switchpack S1 work as a pair. Set position 4 to the first digit and position 5 to the second digit. For example, set 4 ON and 5 OFF for Loop clock source.
- Pin 1 on jumpers is labeled on the board.
- The ON position is labeled on the switchpack.

Glossary

AMI	Alternate Mark Inversion coding format.
BPV	Bipolar Violation. A type of error detected by using a modified bipolar signaling method in which a control code is inserted. Used with AMI coding format.
CD	Carrier Detect. A signal indicating that energy exists on the transmission circuit. Associated with Pin 8 on an EIA-232 interface.
CO	Central Office.
COM port	Communications port. A computer's serial communications port used to transmit to and receive data from a DCE. The DCE connects directly to this port.
CP	Customer Premises.
CPE	Customer Premises Equipment. Terminating equipment supplied by either the customer or some other supplier that is connected to the telecommunications network (e.g., DSUs, terminals, phones, routers, modems).
CRC	Cyclic Redundancy Check. A commonly used method of error detection.
CTS	Clear to Send. An EIA-lead standard for V.24 circuit CT 106; an output signal (DCE-to-DTE).
CV	Code Violation. This is equivalent to a BPV. Used with HDB3 coding format.
DCE	Data Communications Equipment. The equipment that provides the functions required to establish, maintain, and end a connection. It also provides the signal conversion required for communication between the DTE and the network.
DSR	Data Set Ready. An EIA-lead standard for V.24 circuit CT 107; an output signal (DCE-to-DTE).
DTE	Data Terminal Equipment. The equipment, such as computers, printers, and routers, that provide or create data.
DTR	Data Terminal Ready. An EIA-lead standard for V.24 circuit CT 108; an input signal (DTE-to-DCE).
E1	A data signaling rate common outside the United States. A wideband interface operating at 2.048 Mbps defined by CCITT standards G.703 and G.704.
factory defaults	A predetermined set of configuration options for general operation.
FAS	Frame Alignment Signal. A loss of signal (LOS) error detection.
FAW	Frame Alignment Word. A loss of synchronization error detection.
FCC	Federal Communications Commission. Board of Commissioners that regulates all U.S. interstate, intrastate, and foreign electrical communication systems that originate from the United States.
FEBE	Far End Bit Error. Number of errors reported by the remote equipment.
HDB3	High Density Bipolar 3 coding format.
HDSL	High-bit-rate Digital Subscriber Loop. Provides high bandwidth, bi-directional transmission over copper wire for both T1 and E1 services.

HTU	Host Termination Unit. A generic reference to either an HTU-C or HTU-R module.
HTU-C	Host Termination Unit – Central. The module at the CO (central office) or central site end of an HDSL connection. Also known as a Network Termination Unit (NTU).
HTU-M	Host Termination Unit – Maintenance. A carrier-mounted module used to perform maintenance operations on one or more HTU-R and HTU-C modules.
HTU-R	Host Termination Unit – Remote. The module at the CP (customer premises) end of an HDSL connection. Also known as a Line Termination Unit (LTU).
LED	Light Emitting Diode. A status indicator that responds to the presence of a certain conditions.
loopback	Used to test various portions of a data link in order to isolate an equipment or data line problem. A diagnostic procedure that sends a test message back to its origination point.
OOF	Out Of Frame. An error condition in which frame synchronization bits are in error. A network-reported condition.
reset	A reinitialization of the device that occurs at power-up or in response to a reset command.
RTS	Request to Send. An EIA-lead standard for V.24 circuit CT 105; an input signal (DTE-to-DCE).
RXD	Received Data. An EIA-lead standard for V.24 circuit CT 104; an output signal (DCE-to-DTE).
TXD	Transmit Data. An EIA-lead standard for V.24 circuit CT 103; an input signal (DTE-to-DCE).
T1	A data signaling rate common in the United States. A term for a digital carrier facility used to transmit a DS1 formatted signal of 1.544 Mbps.
V.35	ITU-T standard for a high-speed, 34-pin, DCE/DTE interface.

Index

Numbers

7925

- features, 1-1
- models, 1-2

A

AMI line encoding, 4-3

B

board status, 6-2
for remote unit, 6-5

C

cables

- connecting, 2-1
- pin assignments, B-1

card type

- G.703-compatible units, 4-3
- V.35-compatible units, 5-3

changing dip switches and jumpers

- G.703-compatible units, 4-5
- V.35-compatible units, 5-4

clock source options, 5-3

COM port settings, 3-2

configuration examples

- campus, 1-3
- cellular, 1-5
- central office, 1-4

configuration options

- accessing, 4-1, 5-1
- changing, 4-2, 5-2
- G.703-compatible units, 4-3
- G.703-to-G.703, A-2
- G.703-to-V.35, A-4
- summary, A-5
- V.35-compatible units, 5-3
- V.35-to-V.35, A-3

configuration worksheets

- G.703-compatible unit, A-5
- V.35-compatible unit, A-5

connecting system terminal, 3-1

D

data rate for V.35-compatible units, 5-3

displaying

- board status, 6-2
- remote unit status, 6-5
- statistics, 6-3

documents, related, vi

F

features, 1-1

framing options, 4-3

front panel LEDs

- G.703-compatible units, 6-6
- V.35-compatible units, 6-7

G

G.703 to G.703 configuration, A-2

G.703 to V.35 configuration, A-4

H

HDB3 line encoding, 4-3

I

installation, 2-1

interface modes, 3-1

- switching, 3-2

J

jumpers

- G.703-compatible unit, C-1
- V.35-compatible unit, C-3

L

- LEDs, 6-6
 - G.703-compatible unit, 6-6
 - V.35-compatible unit, 6-7
- line build out
 - how to display, 4-6
 - options, 4-3
- line encoding options, 4-3
- local loopback test, 7-2
- loopback tests, 7-1

M

- model numbers, 1-2
- monitoring
 - board status, 6-2
 - performance statistics, 6-3

N

- network configuration examples, 1-3
- network performance statistics, 6-3

P

- package checklist, 2-1
- parts list, 2-1
- payload rate options, 5-3
- PC requirements, 3-2
- performance statistics, 6-3
- pin assignments, B-1
- power cord installation, 2-2

R

- rear panel diagram, 2-2
- related documents, vi
- remote loopback test, 7-3
- remote unit status, 6-5
- resetting the unit, 4-4, 5-4, 7-5

S

- specifications, 1-1
- status
 - Board Status screen, 6-2
 - Performance Monitor screen, 6-3
 - remote unit, 6-5
- Switchpack Mode
 - described, 3-1
 - G.703-compatible units, 4-5
 - V.35-compatible units, 5-4
 - switching to and from, 3-2
- switchpacks
 - G.703-compatible unit, C-1
 - V.35-compatible unit, C-3
 - how to display, 4-5, 5-5

T

- terminal, connecting, 3-1
- terminal cable pin assignments, B-1
- terminal interface, 3-1
- Terminal Mode
 - described, 3-1
 - switching to and from, 3-2
- testing, 7-1
- timing options, 5-3
- transmit timing options, 5-3

U

- user interface, 1-5, 3-1

V

- V.35 to G.703 configuration, A-4
- V.35 to V.35 configuration, A-3
- VT100 interface, 3-1

W

- worksheets, A-1