

Hotwire® Shelf Concentration Module (SCM) Card Installation Instructions

Document Number 8021-A2-GZ40-30

January 2001

What is a Hotwire Shelf Concentration Module?

A Hotwire® Shelf Concentration Module (SCM) is a circuit card assembly (CCA) that contains a parentcard with an ATM switch, a backplane interface, a processor, a cell mux/demux, and an uplink childcard. The childcard determines the type of ATM uplink supported by the SCM.

When the SCM card is used in a Hotwire 8820 GrandSLAM chassis, it aggregates DSL traffic from each of the DSL port cards in the chassis on the chassis' backplane bus and concentrates it onto an ATM interface. The model number of the SCM card differs, depending on what type of ATM uplink childcard is being used.

SCM Card Model	ATM Uplink Childcard
8021	DS3
8022	OC3 with multi-mode fiber
8023	OC3 with single-mode fiber for immediate reach (15 km)
8024	OC3 single-mode fiber for long reach (40 km)
8025	E3
8026	DS1 IMA (ATM Inverse Multiplexing)
8027	E1 IMA (75 ohm)
8028	E1 IMA (120 ohm)

Product Documentation Online

Complete documentation for this product is available at www.paradyne.com.
Select *Library* → *Technical Manuals* → *Hotwire DSL & MVL Systems*.

Select the following documents:

8000-A2-GB22

*Hotwire Management Communications Controller (MCC) Card,
IP Conservative, User's Guide*

8000-A2-GB26

*Hotwire MVL, ReachDSL/MVL, RADSL, IDSL, and SDSL Cards, Models
8310, 8312/8314, 8510/8373/8374, 8303/8304, 8353/8354, and 8343/8344,
User's Guide*

8021-A2-GB20

Hotwire Shelf Concentration Module (SCM) Card User's Guide

Contact your sales or service representative to order a paper copy of a Paradyne document:

- Within the U.S.A., call 1-800-PARADYNE (1-800-727-2396)
- Outside the U.S.A., call 1-727-530-8623

SCM Card Installation Planning

- The Hotwire GrandSLAM chassis is shipped with one of the following installation documents, depending on model type:

Document Number	Document Title
8620-A2-GN20	<i>Hotwire 8620 GrandSLAM Installation Guide</i>
8820-A2-GN20	<i>Hotwire 8820 GrandSLAM Installation Guide</i>

- Refer to the installation guide to:
 - Install and set up the Hotwire GrandSLAM chassis
 - Install the SCM card
 - Connect cables
- After the SCM card is installed, there are configuration procedures that must be performed before you can begin to use the DSL port cards for Internet or intranet connectivity. Refer to the *Hotwire MVL, ReachDSL/MVL, RADSL, IDSL, and SDSL Cards User's Guide* and the *Hotwire Shelf Concentration Module (SCM) Card User's Guide* for detailed configuration procedures. Access these documents using the instructions in [Product Documentation Online](#).

Installing the SCM Card

► Procedure

To install the Hotwire SCM Card in Slot A of the GrandSLAM chassis:

1. If there is a filler plate covering the slot, remove it.
2. Remove the yellow screw covers.
3. Insert the card into the card guides of the slot on the chassis.
4. Carefully slide the card into the slot. Lift the insertion/ejection levers away from the faceplate until the card begins to engage the connectors on the backplane. Then press in on the insertion/ejection levers until the card is fully seated.
5. Verify that the OK SYSTEM indicator on the card's faceplate is ON (winking green). If not, refer to the appropriate Hotwire GrandSLAM Installation Guide.
6. Secure the card by fastening the screws on each end of the faceplate. This is required to maintain proper gasket pressure on the faceplate as well as proper air flow.
7. Attach appropriate connections (e.g., DS3, OC3, etc.) to the uplink.

NOTE:

The IMA uplink has a RJ48M 50-pin connector. See [IMA Uplink Card Connector Pinouts](#) on page 4 for more information.

IMA Uplink Card Connector Pinouts

The IMA uplink has a RJ48M 50-pin Telco connector with 8 Tip/Ring and 8 Tip1/Ring1 connections that conforms to ANSI T1.403-1999. Paradyne offers an octopus cable for use with the IMA uplink (Feature No. 8026-F1-001 for Models 8026 and 8028, and Feature No. 8027-F1-001 for Model 8027). These cables contain a required ferrite to meet EMI requirements. If purchasing other Telco cables, you must attach the supplied ferrite and cable tie as shown below. Contact your service representative for more information.

When connecting the Telco cable, a .87-inch long panhead screw and cable tie must be used to mount the cable to the 50-pin Telco connector as shown below.

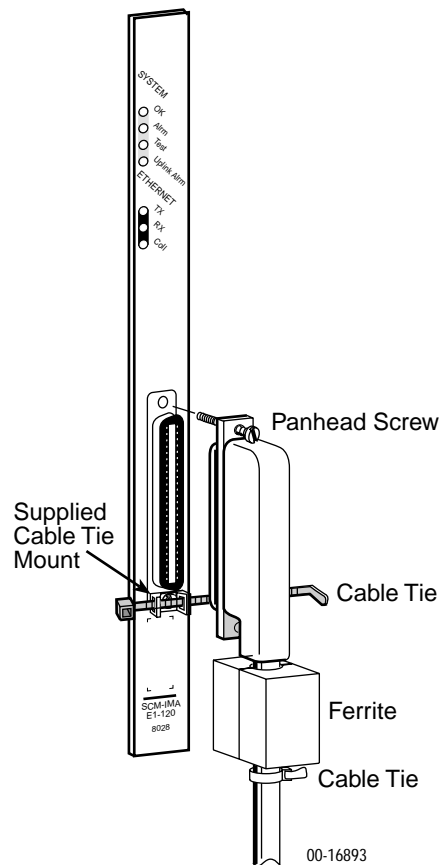

Table 1 lists connector pin assignments for Models 8026 and 8028. Table 2 lists connector pin assignments for Model 8027.

Table 1. Feature No. 8026-F1-001 Connector Pin Assignments (1 of 2)

DS1 or 120 Ohm E1 Port	RJ48M 50-Pin Telco Connector Pinouts	RJ48C Connector Pinouts	Function
Port 1	27	5	Data Out (Tip)
	2	4	Data Out (Ring)
	26	2	Data In (Tip)
	1	1	Data In (Ring)
Port 2	30	5	Data Out (Tip)
	5	4	Data Out (Ring)
	29	2	Data In (Tip)
	4	1	Data In (Ring)
Port 3	33	5	Data Out (Tip)
	8	4	Data Out (Ring)
	32	2	Data In (Tip)
	7	1	Data In (Ring)
Port 4	36	5	Data Out (Tip)
	11	4	Data Out (Ring)
	35	2	Data In (Tip)
	10	1	Data In (Ring)
Port 5	39	5	Data Out (Tip)
	14	4	Data Out (Ring)
	38	2	Data In (Tip)
	13	1	Data In (Ring)
Port 6	42	5	Data Out (Tip)
	17	4	Data Out (Ring)
	41	2	Data In (Tip)
	16	1	Data In (Ring)
Port 7	45	5	Data Out (Tip)
	20	4	Data Out (Ring)
	44	2	Data In (Tip)
	19	1	Data In (Ring)

Table 1. Feature No. 8026-F1-001 Connector Pin Assignments (2 of 2)

DS1 or 120 Ohm E1 Port	RJ48M 50-Pin Telco Connector Pinouts	RJ48C Connector Pinouts	Function
Port 8	48	5	Data Out (Tip)
	23	4	Data Out (Ring)
	47	2	Data In (Tip)
	22	1	Data In (Ring)

Table 2. Feature No. 8027-F1-001 Connector Pin Assignments (1 of 2)

75 Ohm E1 Port	Function	RJ48M 50-Pin Telco Connector Pinouts	BNC Connector
Port 1	Data In	1	Shell (Ring)
		26	Pin (Tip)
	Data Out	2	Shell (Ring)
		27	Pin (Tip)
Port 2	Data In	4	Shell (Ring)
		29	Pin (Tip)
	Data Out	5	Shell (Ring)
		30	Pin (Tip)
Port 3	Data In	7	Shell (Ring)
		32	Pin (Tip)
	Data Out	8	Shell (Ring)
		33	Pin (Tip)
Port 4	Data In	10	Shell (Ring)
		35	Pin (Tip)
	Data Out	11	Shell (Ring)
		36	Pin (Tip)
Port 5	Data In	13	Shell (Ring)
		38	Pin (Tip)
	Data Out	14	Shell (Ring)
		39	Pin (Tip)

Table 2. Feature No. 8027-F1-001 Connector Pin Assignments (2 of 2)

75 Ohm E1 Port	Function	RJ48M 50-Pin Telco Connector Pinouts	BNC Connector
Port 6	Data In	16	Shell (Ring)
		41	Pin (Tip)
	Data Out	17	Shell (Ring)
		42	Pin (Tip)
Port 7	Data In	19	Shell (Ring)
		44	Pin (Tip)
	Data Out	20	Shell (Ring)
		45	Pin (Tip)
Port 8	Data In	22	Shell (Ring)
		47	Pin (Tip)
	Data Out	23	Shell (Ring)
		48	Pin (Tip)

SCM Card LEDs

The following table describes the meaning and states of the LEDs on the Hotwire SCM card faceplate. Example faceplates are shown at left.

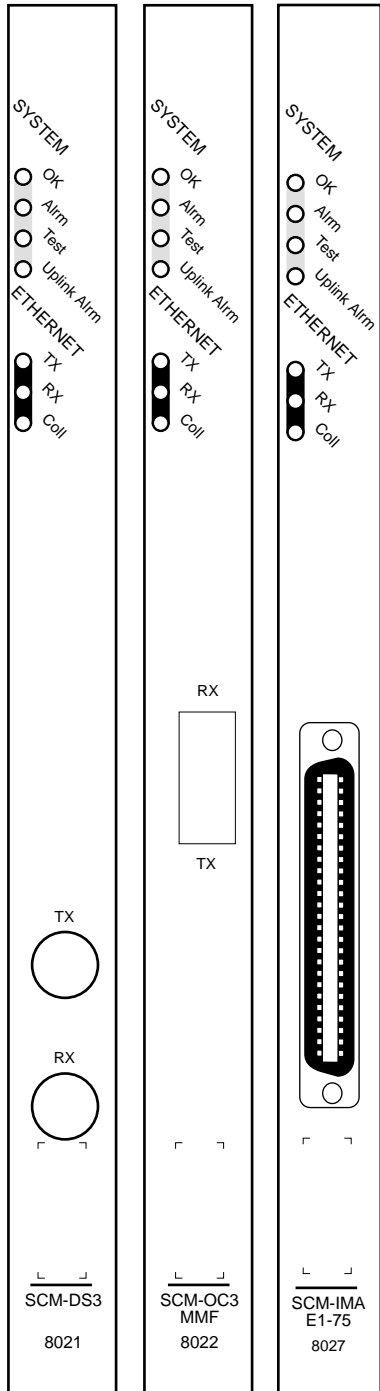

Type	LED	LED is . . .	Indicating . . .
SYSTEM	OK	Green, Winking	Card functioning normally. Winking describes a recurring pulse when the LED is ON longer than OFF at a ratio of approximately 10:1.
		Green, On	SCM card failure. System processing functions have stopped.
		Off	No power to card.
	Alarm	Yellow, On	Alarm is present on SCM.
		Off	No alarms.
	Test	Yellow, On	Test in progress.
		Off	No tests.
	Uplink Alarm	Yellow, On	Alarm is present on the ATM uplink.
		Off	No alarms.
ETHERNET	TX	Green, Blinking	Currently not used.
		Off	
	RX	Green, Blinking	Currently not used.
		Off	
	Coil	Off	Currently not used.
		Yellow, Blinking	

99-16634

99-16635

00-16891

SCM Card Technical Specifications

Table 3. SCM Card Technical Specifications (1 of 2)

Specifications	Criteria*
Size	Length: 10.4 inches (26.42 cm) Height: 11.15 inches (28.32 cm) Width: 1.0 inches (2.54 cm)
Weight	Approximately 1.4 lbs. (0.64 kg)
Approvals Safety Certifications	Refer to the equipment's label for approvals on product.
Power	The SCM card contains a DC-to-DC converter that requires 48V power input. The 48V power is distributed through the Hotwire chassis backplane. Typical Power Dissipation = 26 watts (DS3 and E3) or 28 watts (OC3) or 24 watts (IMA)
Physical Environment Operating temperature Storage temperature Relative humidity Shock and vibration	32° to 140° F (0° to 60° C) -4° F to 158° F (-20° C to 70° C) 5% to 85% (noncondensing) Withstands normal shipping and handling.
Physical Characteristics Internal ATM Switching Fabric	Modular Architecture from 622 Mbps to 5 Gbps, 8192 virtual circuits
DS3 Uplink Specifications Number of ports Connector Type Standards Supported Frame Formats Line Type Data Rates Supported Facility Datalink Protocol Cable Distance	1 DS3 BNC ANSI T1.404-94 Electrical and Jitter, ANSI T1.102-93 Electrical and Jitter Direct or PCLP B3ZS 44.736 Mbps ANSI T1.107.95 Format, ANSI T1.646-95 Format, ANSI T1.646 HEC, ITU-T I.432 Scrambler 75 ohm coaxial 900 feet

* Criteria of technical specifications are subject to change without notice.

Table 3. SCM Card Technical Specifications (2 of 2)

Specifications	Criteria*
OC3 Uplink Specifications	
Number of ports	1 OC3
Connector Type	Fiber SC connectors
Standards Supported	ANSI T1.105.06-94 Jitter, ANSI T1.105.09 94 Jitter, ANSI T1.117.06-91, ITU-T G.957 7/95
Frame Formats	OC3 or STM-1 Operation, Direct Mode only
Line Type	Non-Return to Zero
Data Rates Supported	155.52 Mbps
Facility Datalink Protocol	ANSI T1.105 Format, ANSI T1.646 HEC, ITU-T I.432 Scrambler
Cable Distance	
Model 8022 (MMF)	2 Km (6561.7 feet)
Model 8023 (SMFIR)	15 Km (49,212.6 feet) SMF fiber
Model 8024 (SMFLR)	40 Km (131,234 feet) SMF fiber
E3 Uplink Specifications	
Number of ports	1 E3
Connector Type	BNC
Standards Supported	ETSI ETS 3000 689 Electrical and Jitter
Frame Formats	Direct or PCLP
Line Type	HDB3
Data Rates Supported	34.368 Mbps
Facility Datalink Protocol	ETSI ETS 300 686 PLCP, ETSI ETS 3000 689 Direct, ITU T1.646 HEC, ITU-T I.432 Scrambler
Cable Distance	75 ohm coaxial 900 feet (274.3 meters)
IMA Uplink Specifications	
Number of ports	8 T1 or E1
Connector Type	RJ-48M (50-pin telco)
Standards Supported	RFC 495, ANSI T1.403, ITU G.703/G.704
Frame Formats	T1: Superframe, extended Superframe E1: E1, E1-CRC
Line Type	T1: B8ZS E1: HDB3
Data Rates Supported	T1: 1.544 Mbps per T1 (max. 8 T1) E1: 2.048 Mbps per E1 (max. 8 E1)
Facility Datalink Protocol	ANSI T1.403
Cable Distance	T1/E1 (short haul): 200 meters (656 feet) (LBO=0, -7, -15, -22 dB) T1/E1 (long haul): 2000 meters (6561.7 feet)

* Criteria of technical specifications are subject to change without notice.

Government Requirements

Certain governments require that instructions pertaining to connection to the telephone network be included in the user documentation. Specific instructions that are unique to the SCM Model 8026 have been listed below.

United States – Notice to Users of the Telephone Network

This equipment complies with Part 68 of the FCC rules. On the T1 IMA childcard label that contains, among other information, the FCC registration number. If requested, please provide this information to your telephone company.

If your unit causes harm to the telephone network, the telephone company may discontinue your service temporarily. If possible, they will notify you in advance. But if advance notice is not practical, you will be notified as soon as possible. You will be advised of your right to file a complaint with the FCC.

Your telephone company may make changes in facilities, equipment, operations, or procedures that could affect the proper operation of your equipment. If so, you will be given advance notice so as to give you an opportunity to maintain uninterrupted service.

No repairs may be performed by the user. Should you experience difficulty with this equipment, refer to the [Warranty, Sales, Service, and Training Information](#) on page 12.

Make the T1 network connection using a Universal Service Order Code (USOC) type RJ48M jack for multiline installations or the RJ48C jack for single line installations using the 8026-F1-001 adapter cable. Specify both the Service Order Code 6.0F, as well as the proper Facility Interface Code, to the telephone company when ordering the T1 line. The T1 equipment can be configured to support any of the framing format and line signaling techniques show in the table below. The T1 equipment's configuration must correspond to the T1 line's parameters.

Table 4. T1 Facility Interface Does

Interface Code	Description
04DU9-BN	1.544 Mbps superframe format (SF) without line power
04DU9-DN	1544 Mbps SF and B8ZS without line power
04DU9-1KN	1.544 Mbps ANSI ESF without line power
04DU-1SN	1.544 Mbps ANSI ESF and B8ZS without line power

After the telephone company has installed the requested services and jacks, you can connect the unit to the network. This equipment is designed to be connect to the telephone network or premises wiring using a compatible jack that is Part 68 compliant.

Warranty, Sales, Service, and Training Information

Contact your local sales representative, service representative, or distributor directly for any help needed. For additional information concerning warranty, sales, service, repair, installation, documentation, training, distributor locations, or Paradyne worldwide office locations, use one of the following methods:

- **Internet:** Visit the Paradyne World Wide Web site at www.paradyne.com. (Be sure to register your warranty at www.paradyne.com/warranty.)
- **Telephone:** Call our automated system to receive current information by fax or to speak with a company representative.
 - Within the U.S.A., call 1-800-870-2221
 - Outside the U.S.A., call 1-727-530-2340

Document Feedback

We welcome your comments and suggestions about this document. Please mail them to Technical Publications, Paradyne Corporation, 8545 126th Ave. N., Largo, FL 33773, or send e-mail to userdoc@paradyne.com. Include the number and title of this document in your correspondence. Please include your name and phone number if you are willing to provide additional clarification.

Trademarks

Hotwire and MVL are registered trademarks of Paradyne Corporation. All other products and services mentioned herein are the trademarks, service marks, registered trademarks, or registered service marks of their respective owners.



8021-A2-GZ40-30