



# Shelf Concentration and Processing (SCP) Card Installation Instructions

Document Number 8400-A2-GZ40-60

June 2005

---

## Contents

Software and Firmware License Agreement .....	2
Shelf Concentration and Processing Card Description .....	4
Product Documentation Online .....	5
Package Contents .....	5
Installing the SCP Card .....	6
DS3 or E3 Uplink .....	8
Ethernet Interfaces .....	9
IMA Uplink .....	11
OC3 Uplink .....	12
SCP Card LEDs .....	13
Using the Default Management Address .....	14
Setting the Management Address Using TL1 .....	15
Setting the Management Address Using the CLI (8429) .....	16
Using the Web Interface .....	18
Pin Assignments .....	19
Equipment List .....	23
SCP Card Technical Specifications .....	24
Important Safety Instructions .....	26
Warranty, Sales, Service, and Training Information .....	26
Document Feedback .....	26

---

## Software and Firmware License Agreement

**ONCE YOU HAVE READ THIS LICENSE AGREEMENT AND AGREE TO ITS TERMS, YOU MAY USE THE SOFTWARE AND/OR FIRMWARE INCORPORATED INTO THE PARADYNE PRODUCT. BY USING THE PARADYNE PRODUCT YOU SHOW YOUR ACCEPTANCE OF THE TERMS OF THIS LICENSE AGREEMENT.**

IN THE EVENT THAT YOU DO NOT AGREE WITH ANY OF THE TERMS OF THIS LICENSE AGREEMENT, PROMPTLY RETURN THE UNUSED PRODUCT IN ITS ORIGINAL PACKAGING AND YOUR SALES RECEIPT OR INVOICE TO THE LOCATION WHERE YOU OBTAINED THE PARADYNE PRODUCT OR THE LOCATION FROM WHICH IT WAS SHIPPED TO YOU, AS APPLICABLE, AND YOU WILL RECEIVE A REFUND OR CREDIT FOR THE PARADYNE PRODUCT PURCHASED BY YOU.

The terms and conditions of this License Agreement (the "Agreement") will apply to the software and/or firmware (individually or collectively the "Software") incorporated into the Paradyne product (the "Product") purchased by you and any derivatives obtained from the Software, including any copy of either. If you have executed a separate written agreement covering the Software supplied to you under this purchase, such separate written agreement shall govern.

Paradyne Corporation ("Paradyne") grants to you, and you ("Licensee") agree to accept a personal, non-transferable, non-exclusive, right (without the right to sublicense) to use the Software, solely as it is intended and solely as incorporated in the Product purchased from Paradyne or its authorized distributor or reseller under the following terms and conditions:

1. Ownership: The Software is the sole property of Paradyne and/or its licensors. The Licensee acquires no title, right or interest in the Software other than the license granted under this Agreement.
2. Licensee shall not use the Software in any country other than the country in which the Product was rightfully purchased except upon prior written notice to Paradyne and an agreement in writing to additional terms.
3. The Licensee shall not reverse engineer, decompile or disassemble the Software in whole or in part.
4. The Licensee shall not copy the Software except for a single archival copy.
5. Except for the Product warranty contained in the manual, the Software is provided "AS IS" and in its present state and condition and Paradyne makes no other warranty whatsoever with respect to the Product purchased by you. THIS AGREEMENT EXPRESSLY EXCLUDES ALL OTHER WARRANTIES, WHETHER EXPRESS OR IMPLIED, OR ORAL OR WRITTEN, INCLUDING WITHOUT LIMITATION:
  - a. Any warranty that the Software is error-free, will operate uninterrupted in your operating environment, or is compatible with any equipment or software configurations; and
  - b. ANY AND ALL IMPLIED WARRANTIES, INCLUDING WITHOUT LIMITATION IMPLIED WARRANTIES OF MERCHANTABILITY, FITNESS FOR A PARTICULAR PURPOSE AND NON-INFRINGEMENT.

---

Some states or other jurisdictions do not allow the exclusion of implied warranties or limitations on how long an implied warranty lasts, so the above limitations may not apply to you. This warranty gives you specific legal rights, and you may also have other rights which vary from one state or jurisdiction to another.

6. In no event will Paradyne be liable to Licensee for any consequential, incidental, punitive or special damages, including any lost profits or lost savings, loss of business information or business interruption or other pecuniary loss arising out of the use or inability to use the Software, whether based on contract, tort, warranty or other legal or equitable grounds, even if Paradyne has been advised of the possibility of such damages, or for any claim by any third party.
7. The rights granted under this Agreement may not be assigned, sublicensed or otherwise transferred by the Licensee to any third party without the prior written consent of Paradyne.
8. This Agreement and the license granted under this Agreement shall be terminated in the event of breach by the Licensee of any provisions of this Agreement.
9. Upon such termination, the Licensee shall refrain from any further use of the Software and destroy the original and all copies of the Software in the possession of Licensee together with all documentation and related materials.
10. This Agreement shall be governed by the laws of the State of Florida, without regard to its provisions concerning conflicts of laws.

---

## Shelf Concentration and Processing Card Description

A Shelf Concentration and Processing (SCP) card is a circuit card assembly that comprises a parent card with an ATM switch, a backplane interface, a processor, a cell multiplexer/demultiplexer, and an uplink childcard. The childcard determines the type of uplink supported by the SCP card.

When the SCP card is used in a Broadband Loop Carrier, it aggregates DSL traffic from each of the DSL port cards in the chassis on the BLC's backplane bus and concentrates it onto an ATM or (Model 8429) IP interface. The following models are available:

SCP Card Model	Uplink Childcard
8411	DS3
8412	OC3/STM1 Multimode Fiber
8413	OC3/STM1 Single Mode Fiber Intermediate Reach (15 km)
8414	OC3/STM1 Single Mode Fiber Long Reach (40 km)
8415	E3
8416	8-Port DS1 IMA (Inverse Multiplexing over ATM)
8417	8-Port E1 IMA
8429	Gigabit Ethernet

The SCP card supports the following interface cards:

- 8922 POTS Card
- 8955 ReachDSL ATM Card
- 8965 ADSL ATM Card
- 8968 ADSL2+ ATM Card
- 8975 ReachDSL+ ATM Card
- 8985 SHDSL ATM Card
- 8995 T1 IMA Card
- 8997 E1 IMA Card

With a Management Communications Controller (MCC) card installed in the same BLC, the SCP card also supports Time Division Multiplexer (TDM) SDSL and SHDSL cards, Models 8775, 8777, 8779, and 8799.

---

## Product Documentation Online

Complete documentation for this product is available at [www.paradyne.com](http://www.paradyne.com).  
Select *Support* → *Technical Manuals*.

Document Number	Document Title
8400-A2-GB20	<i>Shelf Concentration and Processing (SCP) Card with ATM Uplink User's Guide</i>
8400-A2-GB21	<i>Shelf Concentration and Processing (SCP) Card with IP Uplink User's Guide</i>
8400-A2-GT20	<i>GranDSLAM 3.x (SCP Card with ATM Uplink) Training Guide</i>
8400-A2-GT21	<i>GranDSLAM 4.x (SCP Card with IP Uplink) Training Guide</i>
8620-A2-GN20	<i>8620 Broadband Loop Carrier Installation Guide</i>
8820-A2-GN20	<i>8820 Broadband Loop Carrier Installation Guide</i>
8900-A2-GB20	<i>ATM Line Cards, Models 8955, 8965, 8968, 8975, and 8985, User's Guide</i>
8922-A2-GN10	<i>8922 POTS Card Installation and User's Guide</i>
8990-A2-GN10	<i>T1 and E1 IMA Cards, Models 8995 and 8997, Installation and User's Guide</i>

To order a paper copy of a Paradyne document, or to speak with a sales representative, please call 727-530-2000.

Refer to the appropriate BLC installation guide to:

- Install and set up the BLC
- Connect cables

After the SCP card is installed, there are configuration procedures that must be performed before you can begin to use the DSL port cards. Refer to the *ATM Line Cards User's Guide* and the *Shelf Concentration and Processing (SCP) Card with ATM Uplink User's Guide* or the *Shelf Concentration and Processing (SCP) Card with IP Uplink User's Guide* for detailed configuration procedures.

## Package Contents

Verify that the shipping carton contains:

- One SCP card in an anti-ESD bag
- One 14-foot serial cable with modular connectors
- One DB9 adapter for use with the serial cable
- This document

If anything is missing or damaged, contact your sales representative.

---

## Installing the SCP Card

SCP cards can be installed in:

- Slot A, Slot B, or both, of the 8820 BLC
- Slot A of the 8620 BLC

### ► Procedure

To install the SCP Card in a BLC:

1. If there is a filler plate covering the slot, remove it.
2. Remove the yellow screw covers.
3. Insert the card into the card guides of the slot on the chassis.

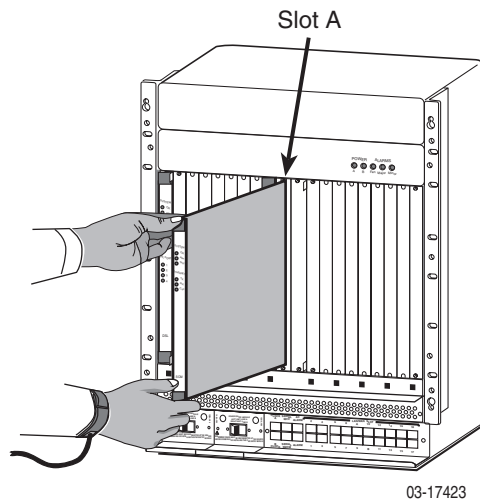

4. Carefully slide the card into the slot until the card meets the connectors on the backplane. Then press in on the insertion/ejection levers until the card is fully seated.
5. Verify that the SYSTEM Active or Standby indicator on the card's faceplate is cycling off and on. See [SCP Card LEDs](#) on page 13.
6. Secure the card by fastening the screws on each end of the faceplate. This is required to maintain proper gasket pressure on the faceplate as well as proper air flow.
7. Attach appropriate connections to the uplink. These are described in the following sections:
  - [DS3 or E3 Uplink](#) on page 8
  - [Ethernet Interfaces](#) on page 9
  - [IMA Uplink](#) on page 11
  - [OC3 Uplink](#) on page 12

---

## Installing Two SCP Cards in the Same BLC

Two SCP cards with ATM uplinks may be installed in one BLC to provide redundancy or load sharing.

- **Redundancy** allows the standby SCP card to become the active SCP card in the event of the failure of the other card or its uplink.
- **Load sharing** allows cross-connections to be made to both uplinks.

There are three basic configurations for paired SCP cards:

- **Y-Cable** – The DS3, E3, or OC3 ports of the two SCP cards are connected to the same uplink device. Traffic is carried over the uplink of the active SCP card. If the active SCP card fails, the backup SCP card automatically becomes the uplink. See [Equipment List](#) on page 23 for available Y-cables.
- **Dual Link** – The SCP cards are connected to different uplink devices. Traffic is carried over the uplink of the active SCP card. Automatic switching occurs if the active SCP card fails or, optionally, if the link fails.
- **Dual Active Manual Load Sharing** – Both SCP cards are active, and connected to different uplink devices. Traffic is carried over both SCP card uplinks. In the case of an uplink or SCP card failure, the traffic on the failing uplink or SCP card stops. Once a failure is detected, you must reconfigure the cross-connections to direct traffic to the working card.

If you use two SCP cards configured for redundancy, and intend to manage the chassis through the active card's Ethernet port, each card must have its own connection to your hub (through the connector marked LAN Slot A or B). The cable cannot be switched after the backup SCP card becomes the active card. Also, since the two SCP cards share the same MAC address, they cannot both be connected to switch ports on your Ethernet switch.

**Table 1. Valid SCP Card Combinations for Load Sharing and Redundancy**

SCP Card Combination	Load Sharing	Redundancy		
		SCP Card Fault	Line Fault	Y-Cable
OC3 and OC3	Yes	Yes	Yes	Yes
DS3 and DS3	Yes	Yes	Yes	Yes
E3 and E3	Yes	Yes	Yes	Yes
DS3 and E3	Yes	No	No	No
E3 and OC3	Yes	No	No	No
OC3 and DS3	Yes	No	No	No

Card combinations other than those shown in [Table 1](#) are invalid.

---

## DS3 or E3 Uplink

SCP cards with a DS3 or E3 uplink have two BNC jacks: one for the transmit direction and one for the receive direction. To cable an SCP card with a DS3 or E3 uplink:

1. Verify that the SCP card is fully inserted in the BLC.
2. Connect the input cable to the RX jack on the faceplate of the SCP card.
3. Connect the output cable to the TX jack on the faceplate of the SCP card.
4. If the chassis is mounted in a rack, direct the cables toward the nearest rail and fasten them with cable ties.

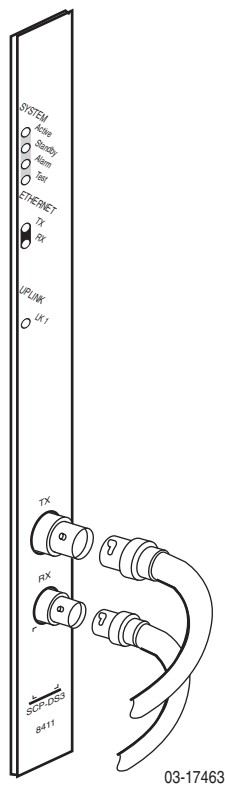

---

## Ethernet Interfaces

The Model 8429 SCP card has three Ethernet ports. Any of them may be used as uplinks or for subtending other equipment:

- A Small Form-Factor Pluggable (SFP) socket designated ETH1 providing, with the appropriate transceiver installed, support for 1000BaseX
- An 8-position modular jack designated ETH1 providing support for 1000BaseT
- An 8-position modular jack designated ETH2 providing support for 10/100BaseT

Only one of the ports designated ETH1 may be used at a time.

### ETH1 1000BaseX Port

To cable an SFP socket:

1. Insert your SFP transceiver into the SFP socket.
2. Remove the plastic dustcover from the transceiver.
3. Insert the LC connector of your fiber optic cable into the transceiver.

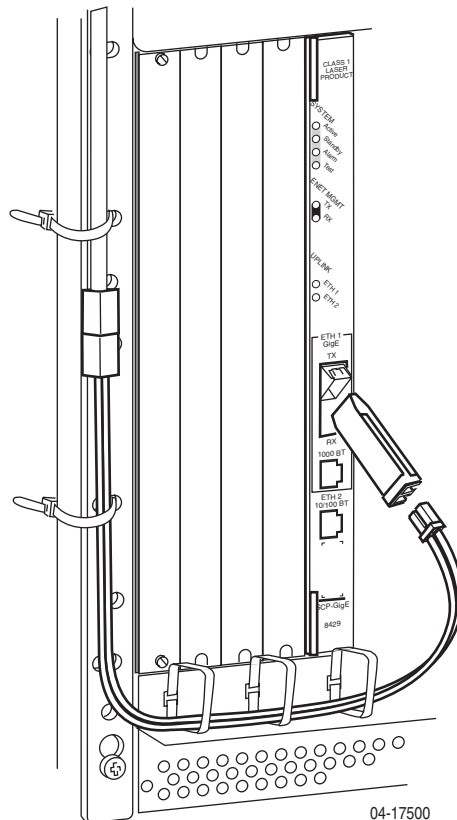

4. Observing the minimum bend radius for your cable, fasten it with cable ties in such a way that it will not be kinked or snagged in the course of other cabling.

If you do not know the specifications for your cable, maintain a radius of at least ten times the cable diameter.

5. Connect the other end of the cable to the uplink interface, such as an Ethernet switch, or the analogous port of a subtended BLC.

## ETH1 1000BaseT and ETH2 10/100BaseT Ports

To cable a copper 1000BaseT or 10/100BaseT port:

1. Plug the 8-position modular plug of your uplink or subtending cable into the ETH1 or ETH2 modular jack.

A straight-through cable can be used regardless of the destination interface, since the port automatically distinguishes between a Medium-Dependent Interface (MDI) and an MDI Crossover (MDIX).

2. Connect the other end of the cable to the uplink interface, such as an Ethernet switch, or the analogous port of a subtended BLC.

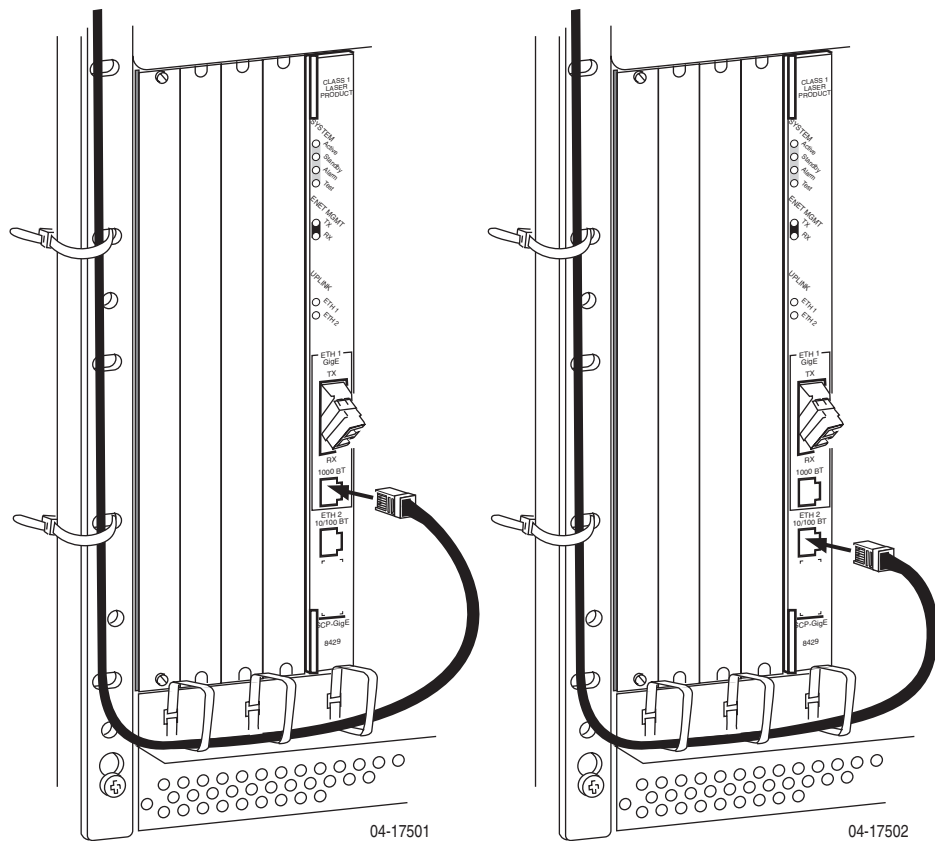

## IMA Uplink

SCP cards with an IMA uplink have an RJ45M-type 50-position connector with eight Tip/Ring and eight Tip1/Ring1 connections that conforms to ANSI T1.403-1999. The following splitter cables are available:

- Feature Number 8026-F1-001 for the Model 8416 SCP card terminates in eight 8-pin modular jacks. See [Table 5, Feature Number 8026-F1-001 Pin Assignments, on page 20](#).

To connect the SCP card to a switch, attach the modular jacks of the 8026-F1-001 cable to T1/E1 crossover cables, and attach the crossover cables to the switch.

- Feature Number 8027-F1-001 for the Model 8417 SCP card terminates in 16 BNC jacks. See [Table 6, Feature Number 8027-F1-001 Pin Assignments, on page 21](#).

To cable an SCP card with an IMA uplink:

1. Feed the supplied cable tie through the openings in the base of the 50-position connector.
2. Fasten the splitter cable to the connector with the captive panhead screw.
3. Wrap the cable tie around the cable and fasten it.

If any ferrite chokes are supplied with the SCP card, they must be installed to meet EMI requirements. Install the choke or chokes as close as possible to the 50-position connector. Hold them in place with an adjacent cable tie.

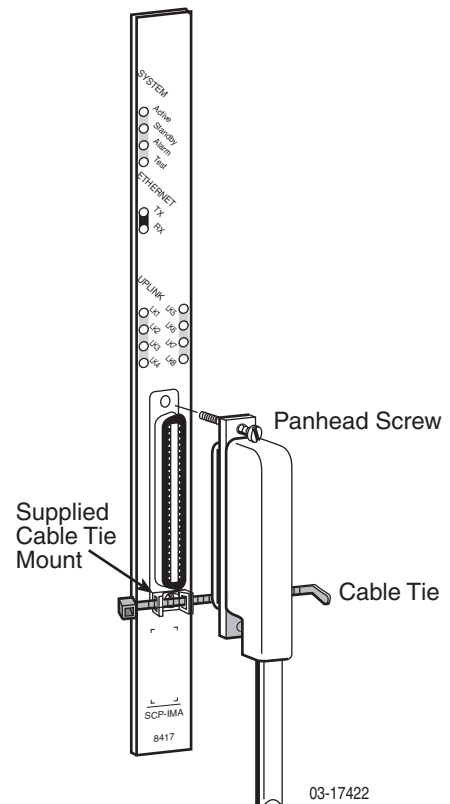

---

## OC3 Uplink

SCP cards with an OC3 uplink use an SFP transceiver that accepts an LC-type connector. To cable an SCP card with an OC3 uplink:

1. Remove the plastic dustcover from the SFP transceiver.
2. Insert the LC connector of your fiber optic cable into the SFP transceiver.

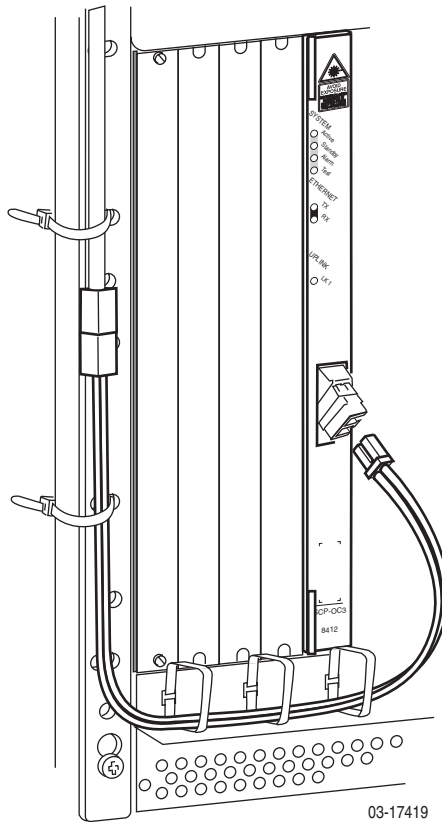

3. Observing the minimum bend radius for your cable, fasten it with cable ties in such a way that it will not be kinked or snagged in the course of other cabling. If you do not know the specifications for your cable, maintain a radius of at least ten times the cable diameter.

# SCP Card LEDs

The following table describes the meaning and states of the LEDs on the SCP card faceplate. Example faceplates are shown at left. OC3 and E3 Models 8412, 8413, 8414, and 8415 have the same LEDs as the DS3 Model 8411 shown.

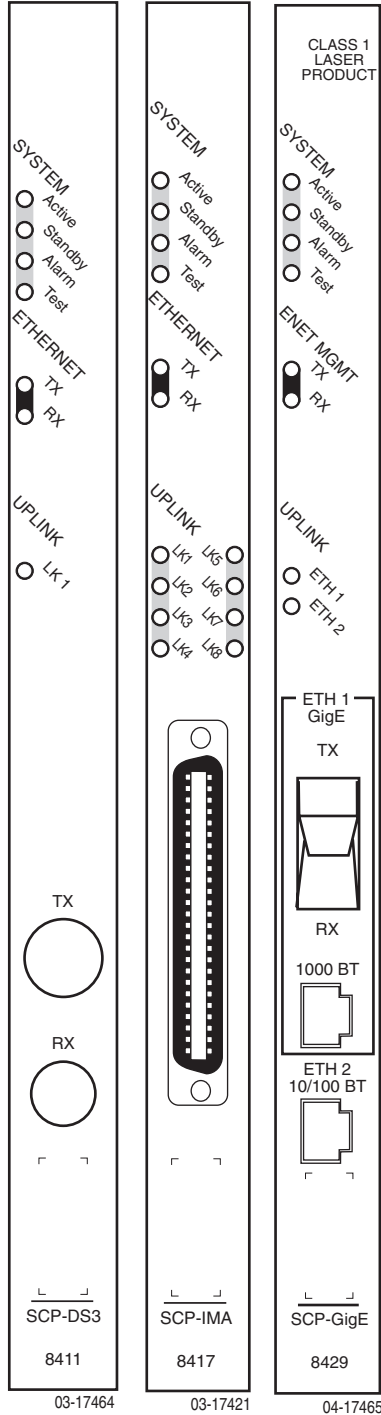

Type	LED	LED is . . .	Indicating . . .
SYSTEM	Active	Green, Slow-cycling	This SCP card is the active card and is functioning normally. Slow-cycling describes a recurring pulse when the LED is on longer than off at a ratio of approximately 10:1.
		Green, On	SCP card failure. System processing functions have stopped.
	Off	No power to card, or this is the standby SCP card.	
	Standby	Green, Slow-cycling	This SCP card is the standby card and is functioning normally. Slow-cycling describes a recurring pulse when the LED is on longer than off at a ratio of approximately 10:1.
		Green, On	SCP card failure. System processing functions have stopped.
Off	No power to card, or this is the active SCP card.		
SYSTEM	Alarm	Yellow	Alarm is present on the SCP card.
	Off	No alarms.	
	Test	Yellow	Test in progress.
Off	No tests.		
ETHERNET or ENET MGMT	TX	Green, Blinking	Data is being transmitted.
		Off	Inactive.
ETHERNET or ENET MGMT	RX	Green, Blinking	Data is being received.
		Off	Inactive.
UPLINK	LK1 or LK1-LK8 or ETH1, ETH2	Green	The link is active.
		Yellow	The link is in an alarm state.
		Off	The link is disabled.

---

## Using the Default Management Address

All SCP cards except the Model 8429 support Transaction Language 1 (TL1). The Model 8429 SCP card supports an easy to use Command Line Interface (CLI). The TL1 interface or the CLI can be used to configure and maintain the system, but the web interface is recommended. You can access the web interface using the default management address or a network address you specify using TL1 or the CLI (see [Setting the Management Address Using TL1](#) on page 15 or [Setting the Management Address Using the CLI \(8429\)](#) on page 16).

### ► Procedure

To use the default management address:

1. Connect a PC to the LAN SCM port of the 8620 BLC or the LAN Slot A or B port (depending on which slot the SCP card is in) of the 8820 BLC using a crossover cable.
2. Access the web interface by typing the default address 10.10.10.10 into the Location field of your web browser. See [Using the Web Interface](#) on page 18.

---

## Setting the Management Address Using TL1

The management address can be set using TL1 on all SCP cards except the Model 8429.

### ► Procedure

To set the management address of the SCP card using TL1:

1. Using the supplied cable and DB9 adapter, connect a PC with a terminal emulation program to the SERIAL SCM jack of your BLC. This gives you access to the TL1 interface.
2. Log in to the SCP card using the ACT-USER command:

```
ACT-USER::SUPERUSER:::ASN#1500
```

The default password, ASN#1500, will appear as asterisks on your screen.

3. Assign an IP address, netmask, and next-hop router using the ED-IPPORT command. For example:

```
ED-IPPORT::ETH-1:100:MANUAL:IPADDR=135.26.10.37,  
NETMASK=255.255.255.0,GATEWAY=135.26.10.30:IS
```

The GATEWAY in the ED-IPPORT command specifies a router for the SCP card to use to create a dynamic route upon receipt of a packet from an unknown host on the Ethernet port. To specify a default gateway for the SCP card (for the routing of packets for which there is no appropriate route), use the SET-NE-ALL command. For example:

```
SET-NE-ALL::COM:100:::DEFROUTER=135.26.10.20;
```

4. Attach the SCP card to your network using the appropriate LAN connection on your BLC:
  - On the 8820 BLC, connect to the LAN SLOT A or LAN SLOT B port, depending on where the SCP card is installed.
  - On the 8620 BLC, connect to the LAN SCM port.

You can now access the web interface by typing into the Location field of your web browser the IP address assigned to the Ethernet port. See [Using the Web Interface](#) on page 18.

In a configuration with two SCP cards, this procedure provides access only to the active SCP card.

---

## Setting the Management Address Using the CLI (8429)

The management address can be set using the CLI on the Model 8429.

### ► Procedure

To set the management address of the SCP card using the CLI:

1. Using the supplied cable and DB9 adapter, connect a PC with a terminal emulation program to the SERIAL SCM jack of your BLC. This gives you access to the CLI.
2. Log in to the SCP card using:

```
Login> SUPERUSER  
Password> ASN#1500
```

The password appears on the screen as asterisks.

The startup procedure differs depending on the type of management used:

- Inband Management – Operates over the uplink.
- Out-of-Band Management – Operates over the LAN SCM port (8620) or LAN Slot A or B (8820)

## Setting the Management Address for Inband Management

With inband management, the BLC is managed using the uplink port.

### ► Procedure

To start up the SCP using inband management:

1. Specify the uplink port using the **configure uplink** command. The uplink must be either **eth1** or **eth2**. For example:

```
PDYN# configure uplink eth1
```

2. Assign an IP address, netmask, and next-hop router using the configure management command. For example:

```
PDYN# configure management inband address 137.90.127.3  
255.255.255.0
```

```
PDYN# configure management default-gateway 137.90.127.1
```

You can now access the web interface by typing into the Location field of your web browser the IP address you have defined. See [Using the Web Interface](#) on page 18.

Do not configure inband and out-of-band management on the same subnet.

---

## Setting for Out-of-Band Management

In out-of-band management, you manage the unit over your LAN. To connect the SCP card to your LAN:

- On the 8620 BLC, connect the LAN SCM port to your LAN

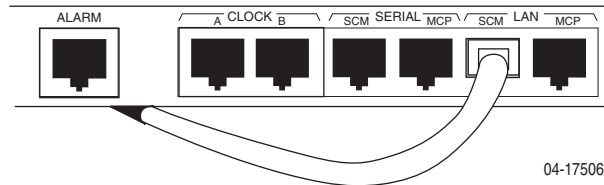

- On the 8820 BLC, connect the LAN SLOT A or LAN SLOT B port (depending on where the SCP card is installed) to your LAN

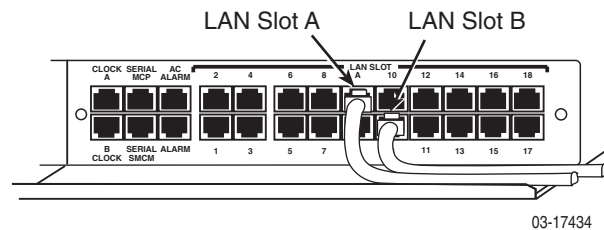

### ► Procedure

To start up the BLC using out-of-band management:

1. Assign an IP address, netmask, and next-hop router using the configure management command. For example:

```
PDYN# configure management out-of-band address  
137.90.80.3 255.255.255.0
```

```
PDYN# configure management default-gateway 137.90.80.1
```

You can now access the web interface by typing into the Location field of your web browser the IP address assigned to out-of-band management. See [Using the Web Interface](#) on page 18.

Do not configure inband and out-of-band management on the same subnet.

# Using the Web Interface

To access the web interface:

## ► Procedure

1. Open your web browser. (Internet Explorer Version 6 or above is recommended.)
2. Type http:// and the IP address of the SCP card into the Address field of your browser window. This is 10.10.10.10 by default, or the address you set using the TL1 interface.

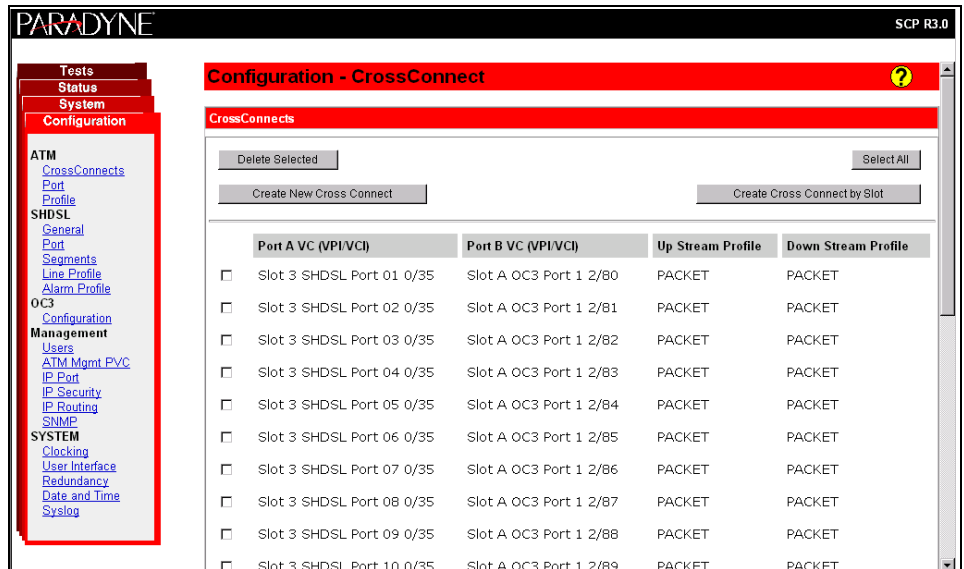

3. A login window appears. Enter the default User ID (SUPERUSER) and Password (ASN#1500), and click on OK. The web interface screen appears.
4. Click on the menu tab appropriate to what you would like to do:
  - Configuration – To configure the system and interfaces
  - Status – To display statistics, status, and contents of memory
  - System – To display system information, download firmware, back up configurations, and modify users
  - Tests – To start and stop tests

A screenshot of the PARADYNE web interface. The top header shows 'PARADYNE' on the left and 'SCP R3.0' on the right. A navigation menu on the left lists categories: Tests, Status, System, Configuration, ATM, SHDSL, OC3, Management, and SYSTEM, with sub-items like CrossConnects, Port, Profile, etc. The main content area is titled 'Configuration - CrossConnect' and contains a table of cross-connects. The table has columns for Port A VC (VPI/VCI), Port B VC (VPI/VCI), Up Stream Profile, and Down Stream Profile. Each row represents a cross-connect between a Slot 3 SHDSL Port and a Slot A OC3 Port, with both profiles set to 'PACKET'. Buttons for 'Delete Selected', 'Select All', 'Create New Cross Connect', and 'Create Cross Connect by Slot' are visible above the table.

	Port A VC (VPI/VCI)	Port B VC (VPI/VCI)	Up Stream Profile	Down Stream Profile
<input type="checkbox"/>	Slot 3 SHDSL Port 01 0/35	Slot A OC3 Port 1 2/80	PACKET	PACKET
<input type="checkbox"/>	Slot 3 SHDSL Port 02 0/35	Slot A OC3 Port 1 2/81	PACKET	PACKET
<input type="checkbox"/>	Slot 3 SHDSL Port 03 0/35	Slot A OC3 Port 1 2/82	PACKET	PACKET
<input type="checkbox"/>	Slot 3 SHDSL Port 04 0/35	Slot A OC3 Port 1 2/83	PACKET	PACKET
<input type="checkbox"/>	Slot 3 SHDSL Port 05 0/35	Slot A OC3 Port 1 2/84	PACKET	PACKET
<input type="checkbox"/>	Slot 3 SHDSL Port 06 0/35	Slot A OC3 Port 1 2/85	PACKET	PACKET
<input type="checkbox"/>	Slot 3 SHDSL Port 07 0/35	Slot A OC3 Port 1 2/86	PACKET	PACKET
<input type="checkbox"/>	Slot 3 SHDSL Port 08 0/35	Slot A OC3 Port 1 2/87	PACKET	PACKET
<input type="checkbox"/>	Slot 3 SHDSL Port 09 0/35	Slot A OC3 Port 1 2/88	PACKET	PACKET
<input type="checkbox"/>	Slot 3 SHDSL Port 10 0/35	Slot A OC3 Port 1 2/89	PACKET	PACKET

---

## Pin Assignments

The following tables show pin assignments for connectors on the faceplates of SCP cards. See the appropriate BLC manual for information about connectors on the chassis.

### BNC Jacks

The following table shows the connections for BNC jacks (Models 8411, 8415).

**Table 2. BNC Jack Connections**

Connector	Label	Connection	Description
Transmit	TX	Pin	Transmit signal
		Shell	Transmit signal return
Receive	RX	Pin	Receive signal
		Shell	Receive signal return

### Ethernet Interface Pin Assignments

The Model 8429 SCP card has three Ethernet interfaces: the ETH1 fiber 1000BaseX SFP interface, and two copper interfaces, as shown in [Table 3, ETH1 Copper 1000BaseT](#), and [Table 4, ETH2 Copper 10/100BaseT](#).

**Table 3. ETH1 Copper 1000BaseT**

Pin	Signal
1	Tip 1
2	Ring 1
3	Tip 2
4	Ring 3
5	Tip 3
6	Ring 2
7	Tip 4
8	Ring 4

**Table 4. ETH2 Copper 10/100BaseT**

Pin	Signal
1	Transmit Data +
2	Transmit Data –
3	Receive Data +
4	--
5	--
6	Receive Data –
7	--
8	--

## IMA Interface Pin Assignments

[Table 5](#) lists connector pin assignments for Model 8416, and the Model 8417 when used with modular connectors for a 120-ohm E1 connection. [Table 6](#) lists connector pin assignments for the Model 8417 when used with BNC connectors for a 75-ohm E1 connection.

**Table 5. Feature Number 8026-F1-001 Pin Assignments (1 of 2)**

DS1 or 120 Ohm E1 Port	50-Position Telco Connector Pinouts	8026-F1-001 RJ48C Connector Pinouts	Function
Port 1	27	5	Data Out (Tip)
	2	4	Data Out (Ring)
	26	2	Data In (Tip)
	1	1	Data In (Ring)
Port 2	30	5	Data Out (Tip)
	5	4	Data Out (Ring)
	29	2	Data In (Tip)
	4	1	Data In (Ring)
Port 3	33	5	Data Out (Tip)
	8	4	Data Out (Ring)
	32	2	Data In (Tip)
	7	1	Data In (Ring)

**Table 5. Feature Number 8026-F1-001 Pin Assignments (2 of 2)**

<b>DS1 or 120 Ohm E1 Port</b>	<b>50-Position Telco Connector Pinouts</b>	<b>8026-F1-001 RJ48C Connector Pinouts</b>	<b>Function</b>
Port 4	36	5	Data Out (Tip)
	11	4	Data Out (Ring)
	35	2	Data In (Tip)
	10	1	Data In (Ring)
Port 5	39	5	Data Out (Tip)
	14	4	Data Out (Ring)
	38	2	Data In (Tip)
	13	1	Data In (Ring)
Port 6	42	5	Data Out (Tip)
	17	4	Data Out (Ring)
	41	2	Data In (Tip)
	16	1	Data In (Ring)
Port 7	45	5	Data Out (Tip)
	20	4	Data Out (Ring)
	44	2	Data In (Tip)
	19	1	Data In (Ring)
Port 8	48	5	Data Out (Tip)
	23	4	Data Out (Ring)
	47	2	Data In (Tip)
	22	1	Data In (Ring)

**Table 6. Feature Number 8027-F1-001 Pin Assignments (1 of 2)**

<b>75 Ohm E1 Port</b>	<b>Function</b>	<b>50-Position Telco Connector Pinouts</b>	<b>BNC Connector</b>
Port 1	Data In	1	Shell (Ring)
		26	Pin (Tip)
	Data Out	2	Shell (Ring)
		27	Pin (Tip)

**Table 6. Feature Number 8027-F1-001 Pin Assignments (2 of 2)**

<b>75 Ohm E1 Port</b>	<b>Function</b>	<b>50-Position Telco Connector Pinouts</b>	<b>BNC Connector</b>
Port 2	Data In	4	Shell (Ring)
		29	Pin (Tip)
	Data Out	5	Shell (Ring)
		30	Pin (Tip)
Port 3	Data In	7	Shell (Ring)
		32	Pin (Tip)
	Data Out	8	Shell (Ring)
		33	Pin (Tip)
Port 4	Data In	10	Shell (Ring)
		35	Pin (Tip)
	Data Out	11	Shell (Ring)
		36	Pin (Tip)
Port 5	Data In	13	Shell (Ring)
		38	Pin (Tip)
	Data Out	14	Shell (Ring)
		39	Pin (Tip)
Port 6	Data In	16	Shell (Ring)
		41	Pin (Tip)
	Data Out	17	Shell (Ring)
		42	Pin (Tip)
Port 7	Data In	19	Shell (Ring)
		44	Pin (Tip)
	Data Out	20	Shell (Ring)
		45	Pin (Tip)
Port 8	Data In	22	Shell (Ring)
		47	Pin (Tip)
	Data Out	23	Shell (Ring)
		48	Pin (Tip)

## Equipment List

Use the following feature numbers to order SCP cards and related equipment.

**Table 7. Feature Numbers**

Description	Feature Number
<i>Cards</i>	
SCP Card: DS3	8411-B2-000
SCP Card: OC3/STM1 Multimode Fiber	8412-B1-000
SCP Card: OC3/STM1 Single Mode Fiber Intermediate Reach	8413-B2-000
SCP Card: OC3/STM1 Single Mode Fiber Long Reach	8414-B2-000
SCP Card: E3	8415-B1-000
SCP Card: 8-Port DS1 IMA	8416-B2-000
SCP Card: 8-Port E1 IMA	8417-B2-000
SCP Card: Gigabit Ethernet (order SFP transceiver separately)	8429-B1-000
MCP Card for use with SCP Card	8900-B1-211
ADSL2 ATM Line Card 24 ports Annex A	8965-B1-000
ReachDSL 2.2 ATM Line Card 24 ports	8955-B1-000
G.SHDSL ATM Line Card 24 ports	8985-B1-000
T1 IMA Card	8995-B1-001
E1 IMA Card	8997-B1-001
<i>Cables and SFP Transceivers</i>	
LC-to-SC Conversion Cable for SCP Multi-Mode Fiber	8400-F1-001
LC-to-SC Conversion Cable for SCP Single Mode Fiber	8400-F1-002
Y-Cable for SCP Redundancy: LC Connections, Multi-Mode Fiber	8400-F1-003
Y-Cable for SCP Redundancy: LC connections, Single Mode Fiber	8400-F1-004
Y-Cable for SCP Redundancy: SC Connections, Multi-Mode Fiber	8400-F1-005
Y-Cable for SCP Redundancy: SC Connections, Single Mode Fiber	8400-F1-006
Y-Cable for SCP Redundancy: DS3 and E3	8400-F1-007
50-Position Connector to Eight 8-Pin Modular Jacks Cable	8026-F1-001
50-Position Connector to Sixteen BNC Jacks Cable	8027-F1-001
Single-Mode 1000BaseLX SFP Transceiver (10 km, 1310 nm FP-LD)	4200-F3-000
Single-Mode 1000BaseLX SFP Transceiver (40 km, 1310 nm FP-LD)	4200-F3-001
Single-Mode 1000BaseLX SFP Transceiver (80 km, 1550 nm FP-LD)	4200-F3-002
Multimode 1000BaseSX SFP Transceiver (0.55 km, 850 nm VCSEL)	4200-F3-003

## SCP Card Technical Specifications

**Table 8. SCP Card Technical Specifications (1 of 2)**

Specifications	Criteria
<b>Size</b>	Length: 10.4 inches (26.42 cm) Height: 11.15 inches (28.32 cm) Width: 1.0 inches (2.54 cm)
<b>Weight</b>	Approximately 1.7 lbs. (0.76 kg)
<b>Approvals</b> Safety Certifications	Refer to the equipment's label for approvals on product.
<b>Power</b>	The SCP card contains a DC-to-DC converter that requires 48V power input. The 48V power is distributed through the BLC backplane.
<b>Power Dissipation</b>	DS3: 32 watts E3: 32 watts GigE: 39 watts IMA: 32 watts OC3: 29 watts
<b>Physical Environment</b> Operating temperature Storage temperature Relative humidity Shock and vibration	Model 84xx-B1: 32° to 140° F (0° to 60° C) Model 8415-B1: -40° to 149° F (-40° to 65° C) Model 84xx-B2: -40° to 149° F (-40° to 65° C) Model 84xx-B1: -4° F to 158° F (-20° C to 70° C) Model 8415-B1: -40° F to 185° F (-40° C to 85° C) Model 84xx-B2: -40° F to 185° F (-40° C to 85° C) 5% to 85% (noncondensing) Withstands normal shipping and handling.
<b>DS3/E3 Uplink Specifications</b> Number of ports Connector Type Standards Supported Frame Formats Line Type Data Rates Supported	1 DS3/E3 Two 75-ohm BNC jacks Operations, violations, alarm states, performance statistics: ANSI T1.107-1995, ANSI T1.646-1995 Output jitter: ITU G.709, ITU G.783 DS3 electrical specifications: ITU G.709 DS3 ATM physical layer: ATM Forum af-phy-0054.000 HEC generation, calculation, error detection: ANSI T1.646, ITU T1.646 PLCP, Direct B3ZS DS3: 44.736 Mbps E3: 34.368 Mbps

**Table 8. SCP Card Technical Specifications (2 of 2)**

Specifications	Criteria
<b>Ethernet Interfaces</b> ETH1 Fiber ETH1 Copper ETH2 Copper	SFP socket supporting 1000BaseX full or half duplex 8-pin modular socket supporting 1000BaseT full duplex 8-pin modular socket supporting 10/100BaseT full or half duplex
<b>IMA Uplink Specifications</b> Number of ports Connector Type Standards Supported Frame Formats Line Type Data Rates Supported Facility Datalink Protocol Cable Distance	8 T1 or E1 RJ45M-type (50-pin telco) RFC 495, ANSI T1.403, ITU G.703/G.704 T1: Superframe, extended Superframe E1: E1, E1-CRC T1: B8ZS E1: HDB3 T1: 1.544 Mbps per T1 (max. 8 T1) E1: 2.048 Mbps per E1 (max. 8 E1) ANSI T1.403 T1/E1 (short haul): 200 meters (656 feet) (LBO=0, -7, -15, -22 dB) T1/E1 (long haul): 2000 meters (6561.7 feet)
<b>OC3 Uplink Specifications</b> Number of ports Connector Type Standards Supported Frame Formats Line Type Data Rates Supported Facility Datalink Protocol Cable Distance Model 8412 (MMF) Model 8413 (SMFIR) Model 8414 (SMFLR)	1 OC3 Duplex LC Socket ANSI T1.105.06-94 Jitter, ANSI T1.105.09 94 Jitter, ANSI T1.117.06-91, ITU-T G.957 7/95 OC3 or STM-1 Operation, Direct Mode only Non-Return to Zero 155.52 Mbps ANSI T1.105 Format, ANSI T1.646 HEC, ITU-T I.432 Scrambler 0–2 km (0–6,562 feet) Multimode fiber 0–15 km (0–49,213 feet) Single-mode fiber 10–40 km (32,809–131,234 feet) Single-mode fiber

---

## Important Safety Instructions

The Ethernet and OC3 configurations of the SCP circuit card have provisions for the customer to install Class 1 laser transceivers to provide optical coupling to the telecommunications network. Once a Class 1 laser is installed, the equipment is considered to be a Class 1 laser product (Appareil à Laser de Classe 1). If the Class 1 laser device is not purchased from Paradyne Corp., the customer is responsible to insure that the Class 1 AEL (Allowable Emissions Limit) per EN/IEC 60825 is not exceeded after the laser transceivers have been installed. Do not install laser products whose class rating is greater than 1. Refer to the important safety instructions that accompany the transceiver prior to installation. Only laser Class 1 devices certified for use in the country of installation by the cognizant agency are to be utilized with this product. Also, laser warnings are to be provided in accordance with IEC 60825-1 and its Amendments 1 and 2, as well as 21 CFR 1010 and 1040.10(g).

## Warranty, Sales, Service, and Training Information

Contact your local sales representative, service representative, or distributor directly for any help needed. For additional information concerning warranty, sales, service, repair, installation, documentation, training, distributor locations, or Paradyne worldwide office locations, use one of the following methods:

- **Internet:** Visit the Paradyne World Wide Web site at [www.paradyne.com](http://www.paradyne.com). (Be sure to register your warranty at [www.paradyne.com/warranty](http://www.paradyne.com/warranty).)
- **Telephone:** Call our automated system to receive current information by fax or to speak with a company representative.
  - Within the U.S.A., call 1-800-870-2221
  - Outside the U.S.A., call 1-727-530-2340

## Document Feedback

We welcome your comments and suggestions about this document. Please mail them to Technical Publications, Paradyne Corporation, 8545 126th Ave. N., Largo, FL 33773, or send e-mail to [userdoc@paradyne.com](mailto:userdoc@paradyne.com). Include the number and title of this document in your correspondence. Please include your name and phone number if you are willing to provide additional clarification.



\*8400-A2-GZ40-60\*