

Hotwire 8715 E1 SDSL Termination Unit Installation Instructions

Document Number 8715-A2-GN10-00

January 1998

Hotwire 8715 E1 SDSL Termination Unit

The Hotwire 8715 Termination Unit is a circuit card assembly (CCA) that contains four E1 Symmetric Digital Subscriber Line (SDSL) ports. When the 8715 Termination Unit is used in a Hotwire 8600 or 8800 Digital Subscriber Line Access Multiplexer (DSLAM) chassis, it transports 2048 kbps signals over traditional twisted-pair telephone wiring.

▲ HANDLING PRECAUTIONS FOR STATIC-SENSITIVE DEVICES



This product is designed to protect sensitive components from damage due to electrostatic discharge (ESD) during normal operation. When performing installation procedures, however, take proper static control precautions to prevent damage to equipment. If you are not sure of the proper static control precautions, contact your nearest sales or service representative.

Package Checklist

Verify that your package contains the following:

- Hotwire 8715 Circuit Card
- Warranty card
- Hotwire 8715 E1 SDSL Termination Unit User's Guide*, Document No. 8715-A2-GB20

Tool Required

- Small- to medium-size flat-blade screwdriver.

Technical Specifications

Specifications	Criteria*												
Size	Length 10 inches (25.4 cm) Height 12.3 inches (31.1 cm) Width 1 inch (2.5 cm)												
Weight	Approximately 1.3 lbs. (0.6 kg)												
Approvals Safety Certifications	Refer to the equipment's label for approvals on product.												
Power	The 8715 Termination Unit contains a DC-to-DC converter that requires –48V power input. The –48V power is distributed through the Hotwire DSLAM backplane. Maximum Power Dissipation = 19 watts												
Cables and Cable Guide	<table border="1"> <thead> <tr> <th>Part Number</th> <th>Description</th> </tr> </thead> <tbody> <tr> <td>8700-F1-500</td> <td>Cable Guide for 8800 DSLAM</td> </tr> <tr> <td>8700-F1-501</td> <td>V.35: 100-Pin Plug to Four MS34 Receptacles</td> </tr> <tr> <td>8700-F1-502</td> <td>X.21: 100-Pin Plug to Four DB15 Receptacles</td> </tr> <tr> <td>8700-F1-503</td> <td>RS449: 100-Pin Plug to Four DB37 Receptacles</td> </tr> <tr> <td>8700-F1-504</td> <td>EIA-530A: 100-Pin Plug to Four DB25 Receptacles</td> </tr> </tbody> </table>	Part Number	Description	8700-F1-500	Cable Guide for 8800 DSLAM	8700-F1-501	V.35: 100-Pin Plug to Four MS34 Receptacles	8700-F1-502	X.21: 100-Pin Plug to Four DB15 Receptacles	8700-F1-503	RS449: 100-Pin Plug to Four DB37 Receptacles	8700-F1-504	EIA-530A: 100-Pin Plug to Four DB25 Receptacles
Part Number	Description												
8700-F1-500	Cable Guide for 8800 DSLAM												
8700-F1-501	V.35: 100-Pin Plug to Four MS34 Receptacles												
8700-F1-502	X.21: 100-Pin Plug to Four DB15 Receptacles												
8700-F1-503	RS449: 100-Pin Plug to Four DB37 Receptacles												
8700-F1-504	EIA-530A: 100-Pin Plug to Four DB25 Receptacles												
Physical Environment Operating temperature Storage temperature Relative humidity Shock and vibration	32° to 122° F (0° to 50° C) –4° F (–20° C) to 158° F (70° C) 5% to 85% (noncondensing) Withstands normal shipping and handling.												
* Technical specifications are subject to change without notice.													

Planning the 8715 Termination Unit Installation

Review the following list to help plan for the installation.

- Obtain the applicable cables; refer to the next section, *Cables You Need*.
- Make sure the Hotwire DSLAM chassis is installed and power is supplied to the chassis.
- After the 8715 Termination Unit is installed, there are configuration procedures that must be performed before you can begin to use the 8715 Termination Unit. Refer to the *Hotwire 8715 E1 SDSL Termination Unit User's Guide*, for more detailed configuration procedures.

Cables You Need

The following customer-provided cables are used with this product.

For the network connection:

- Plug-ended Telco 50-pin cable for connection from the Hotwire 8600 DSLAM LINE port or one of the Hotwire 8800 DSLAM LINES ports to the Main Distribution Frame (MDF) or other demarcation point.

For the DTE connection, one of the following:

- 100-pin plug to four DB15 (X.21)
- 100-pin plug to four DB25 (EIA-530A)
- 100-pin plug to four DB37 (RS-449)
- 100-pin plug to four MS34 (V.35)

See *Technical Specifications* on page 2 for part numbers of the DTE cables. For more information refer to Appendix D, *Cables and Pin Assignments*, in the User's Guide.

Installing DSL Cards

Use a small- to medium-size flat-blade screwdriver to install the 8715 Termination Unit.

When using a . . .	Install the 8715 Termination Unit in . . .
Hotwire 8600 DSLAM base chassis	Slot 2 or 3 (Slot 1 of the Hotwire 8600 DSLAM base chassis must contain a Management Communications Controller (MCC) card.)
Hotwire 8600 DSLAM expansion chassis	Slot 1, 2, or 3
Hotwire 8800 DSLAM chassis	Any one of the first 18 slots (i.e., Slot 1 through 18)

An 8715 Termination Unit can be installed, removed, and replaced from a Hotwire DSLAM chassis without disrupting service to the other cards in the chassis.

NOTE:

When installing the 8715 Termination Unit, you need to remove the filler plate before proceeding.

Do not discard unused filler plates. Each slot in the chassis must contain a circuit card or a filler plate. Store all unused filler plates in a safe place. You may need to use the filler plates to cover open slots in the chassis at a later time.

► Procedure

To install a 8715 Termination Unit:

1. Determine in which slot the 8715 Termination Unit will be installed. Verify that cards in adjacent slots have been fastened.
2. Remove the filler plate from the installation slot.
3. Insert the 8715 Termination Unit into this slot:
 - For a **Hotwire 8600 DSLAM chassis** – hold the 8715 Termination Unit horizontally with component side facing up and insert it into the left and right card guides.

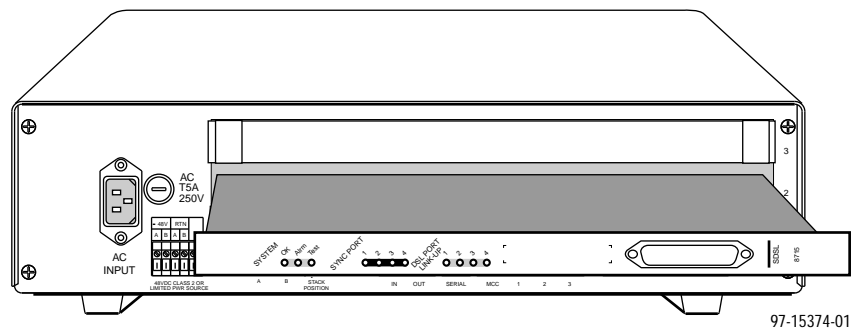

- For a **Hotwire 8800 DSLAM chassis** – hold the 8715 Termination Unit vertically with component side facing right and insert it into the top and bottom card guides.

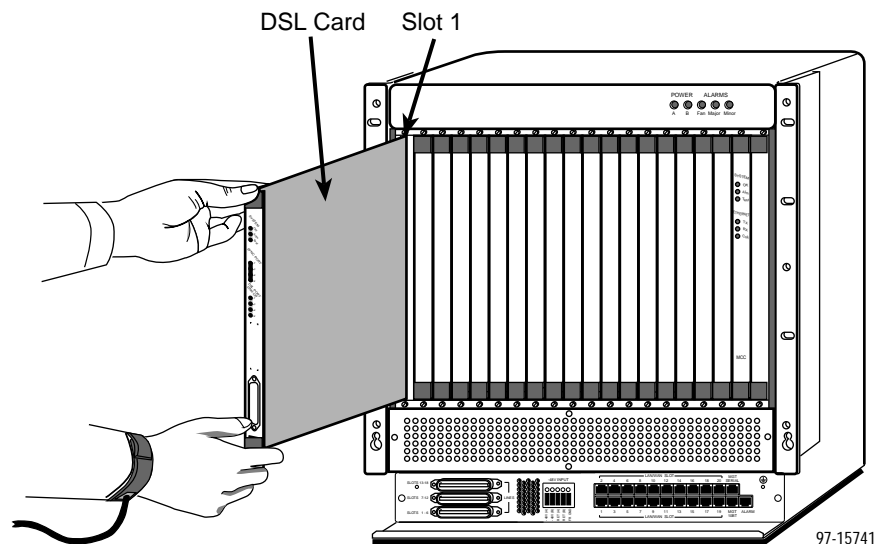

-
- Slide the 8715 Termination Unit into the slot until the power and network connectors seat firmly in the mating connectors on the backplane.

CAUTION:

Do not force the 8715 Termination Unit into the slot. If it does not seat properly, remove the card and reinstall it. If it still does not seat properly, call your service representative.

The 8715 Termination Unit performs a power-up self-test. All of the LEDs turn ON and OFF briefly. When the self-test is completed successfully, the SYSTEM OK LED will turn ON. Make sure the SYSTEM OK indicator on the 8715 Termination Unit faceplate is ON.

- If the LED is not ON, refer to Chapter 6, *Messages and Troubleshooting*, in the User's Guide.
- Secure the 8715 Termination Unit by fastening the screws at each end of the faceplate.

NOTE:

The 8715 Termination Units may be replaced without system disruption (i.e., you can remove and re-install a card without powering down the Hotwire DSLAM chassis and disrupting service to the other cards). To remove an 8715 Termination Unit from the Hotwire DSLAM chassis, unfasten the screws on both ends of the faceplate. Then push the ejector handles outward and slide the card out.

Ensure that adjacent cards are fastened before removing a card.

When swapping the old 8715 Termination Unit with a new 8715 Termination Unit, note that the 8600 DSLAM retains the Media Access Control (MAC) address, also referred to as the physical address. This means that the new 8715 Termination Unit will have the same MAC address as the old one.

Cable Management

The optional Cable Guide (see *Technical Specifications* on page 2 for its part number) connects to the front of the Hotwire 8800 DSLAM and provides strain relief and control of the DTE cables. Install the Cable Guide before installing the cables.

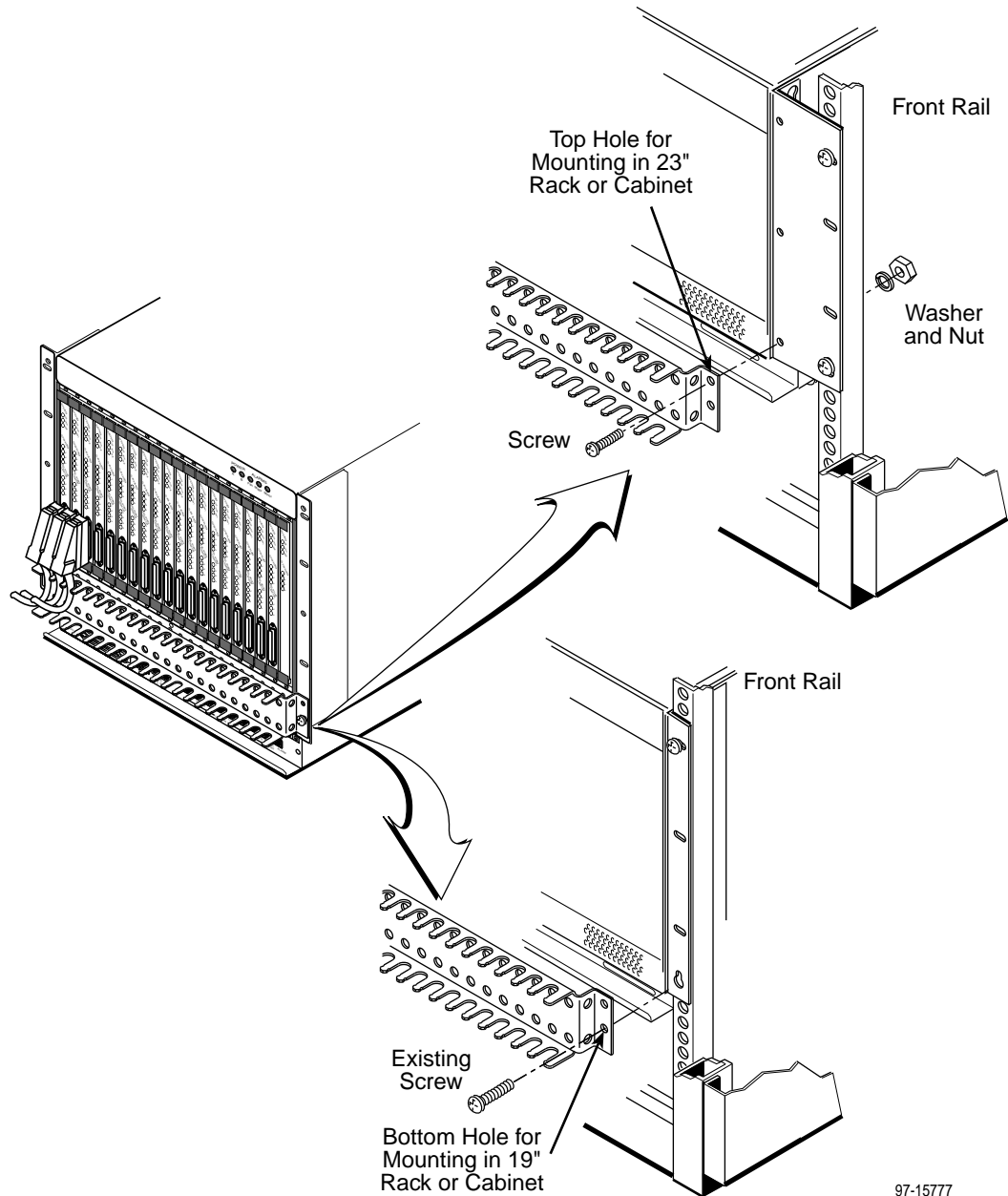

Connecting to the DTE Equipment

Connection to the four ports of the 8715 Termination Unit is through the 100-pin EIA-530 interface connector on its faceplate. Use one of the DTE cables listed under *Cables You Need* on page 3.

► Procedure

To connect the Hotwire 8715 Termination Unit to your DTE equipment:

1. Connect the 100-position connector of the cable to the connector on the faceplate of the 8715 Termination Unit. Align one end of the cable connector with the card connector, then push on the cable connector until it seats.

The end of the cable connector has a release button. To remove the connector, depress the release button and pull the connector away from the card.

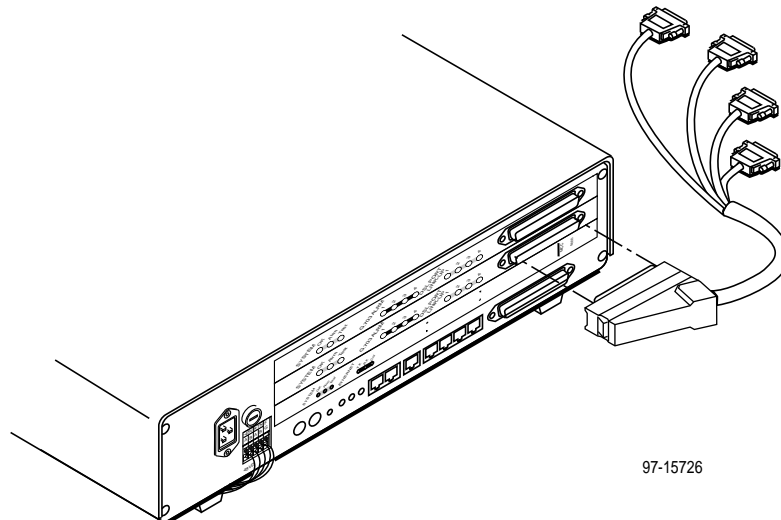

2. Feed the cable through the Cable Guide if it is in use. When all cables are installed, anchor them with cable ties to the rack, DSLAM, or Cable Guide.
3. Connect the four terminating connectors to your DTE equipment.

Connecting to an MDF

You can connect the Hotwire DSLAM chassis containing the 8715 Termination Unit to an MDF or other demarcation point. Do not connect it to a POTS splitter.

► Procedure

To connect the Hotwire DSLAM chassis containing the 8715 Termination Unit to an MDF:

1. Plug the Telco 50-pin cable into the appropriate LINE port on the front panel of the chassis:

— On a Hotwire 8600 DSLAM chassis:

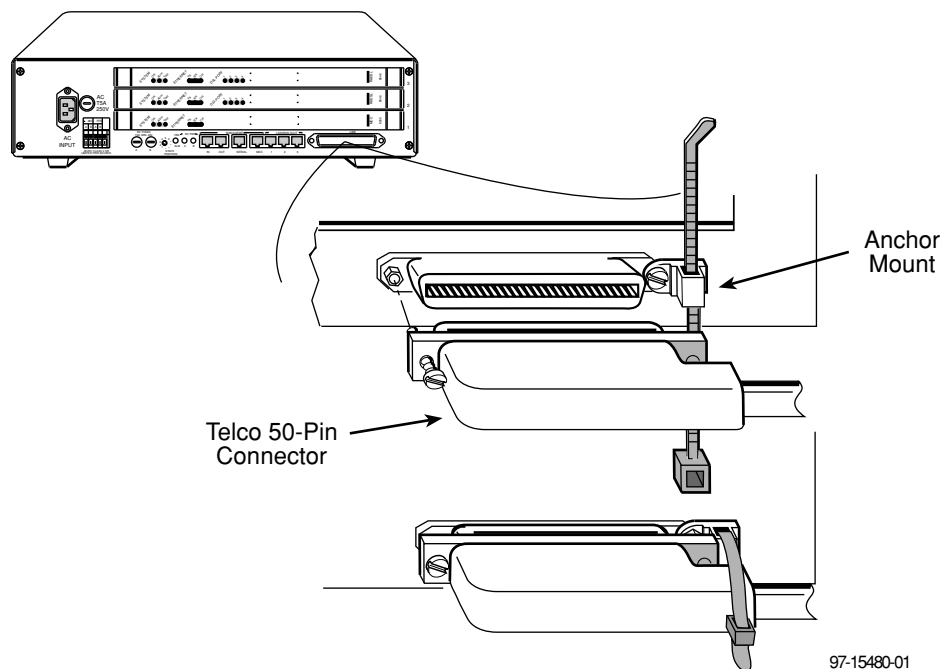

— On a Hotwire 8800 DSLAM chassis:

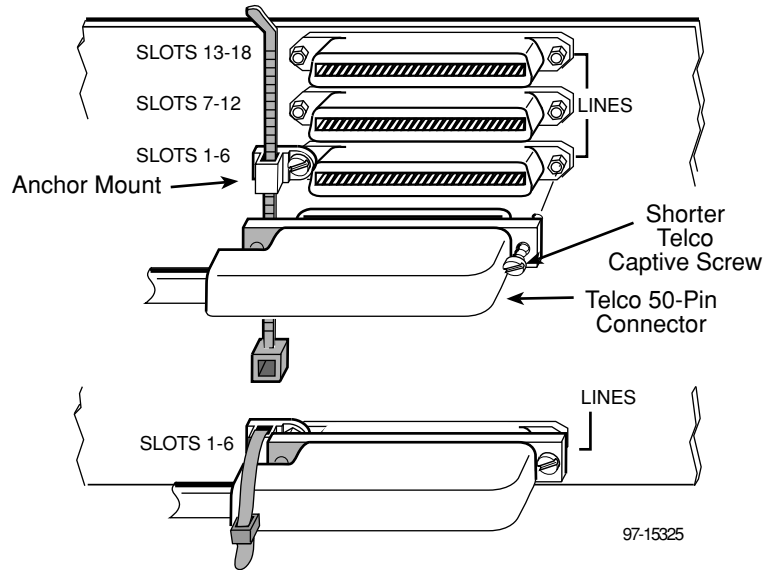

2. Replace the longer Telco cable captive screw with a shorter connector captive screw, which is provided with the Hotwire DSLAM chassis.
3. Insert a cable tie (provided with Hotwire DSLAM chassis) through the tie mount to hold the Telco 50-pin connector in place. If more than one Telco cable is being connected, span the two or three connectors.
4. Make sure the other end is connected to the appropriate MDF or demarcation point.

Refer to Appendix D, *Cables and Pin Assignments*, in the User's Guide for pinouts.

NOTE:

If you are connecting the Telco 25-pair, 50-pin cable to an MDF, a converter may be necessary for terminating the other end of the cable on a punchdown block before cross-connecting to an MDF.

8715 Termination Unit LEDs

The following table describes the meaning and states of the LEDs on the 8715 Termination Unit faceplate.

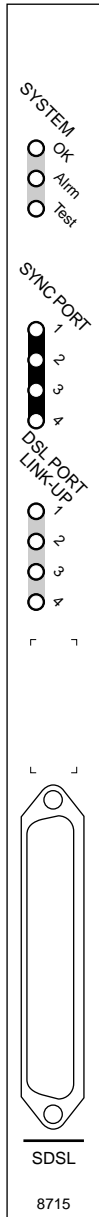

97-15712

Type	LED	LED is . . .	Indicating . . .
SYSTEM	OK	Green Off	Normal operation; card functioning normally. No power to card, or card failure.
	Alarm	Amber Off	Device failure, or Power-On Self Test (POST) failure. No alarms.
	Test	Amber Amber, flashing Off	Loopback test or 511 test pattern in progress. POST in progress. No tests.
SYNC PORT	1, 2, 3, 4	Green	Interchange circuits for the port are in the correct state to transmit and receive data.
		Amber	The port is configured to monitor DTR and/or RTS and no monitored lead is asserted.
		Amber, flashing	Data Channel Loopback (DCLB) or Data Terminal Loopback (DTLB) is active on the port.
	Off	The port is disabled.	
DSL PORT LINK-UP	1, 2, 3, 4	Green Off Amber Amber, flashing	DSL link is up. DSL link is down. DSL training in progress. OOF condition.



8715-A2-GN10-00