



**HOTWIRE[®] 8775
M/SDSL TERMINATION UNIT**

USER'S GUIDE

Document No. 8775-A2-GB20-40

July 1999

Copyright © 1999 Paradyne Corporation.
All rights reserved.
Printed in U.S.A.

Notice

This publication is protected by federal copyright law. No part of this publication may be copied or distributed, transmitted, transcribed, stored in a retrieval system, or translated into any human or computer language in any form or by any means, electronic, mechanical, magnetic, manual or otherwise, or disclosed to third parties without the express written permission of Paradyne Corporation, 8545 126th Ave. N., Largo, FL 33773.

Paradyne Corporation makes no representation or warranties with respect to the contents hereof and specifically disclaims any implied warranties of merchantability or fitness for a particular purpose. Further, Paradyne Corporation reserves the right to revise this publication and to make changes from time to time in the contents hereof without obligation of Paradyne Corporation to notify any person of such revision or changes.

Changes and enhancements to the product and to the information herein will be documented and issued as a new release to this manual.

Warranty, Sales, Service, and Training Information

Contact your local sales representative, service representative, or distributor directly for any help needed. For additional information concerning warranty, sales, service, repair, installation, documentation, training, distributor locations, or Paradyne worldwide office locations, use one of the following methods:

- **Internet:** Visit the Paradyne World Wide Web site at **www.paradyne.com**. (Be sure to register your warranty there. Select *Service & Support* → *Warranty Registration*.)
- **Telephone:** Call our automated system to receive current information by fax or to speak with a company representative.
 - Within the U.S.A., call 1-800-870-2221
 - Outside the U.S.A., call 1-727-530-2340

Document Feedback

We welcome your comments and suggestions about this document. Please mail them to Technical Publications, Paradyne Corporation, 8545 126th Ave. N., Largo, FL 33773, or send e-mail to **userdoc@paradyne.com**. Include the number and title of this document in your correspondence. Please include your name and phone number if you are willing to provide additional clarification.

Trademarks

All products and services mentioned herein are the trademarks, service marks, registered trademarks or registered service marks of their respective owners.



Printed on recycled paper

Important Safety Instructions

1. Read and follow all warning notices and instructions marked on the product or included in the manual.
2. Input power to this product must be provided by one of the following: (1) a UL Listed\CSA Certified power source with a class 2 or Limited Power Source (LPS) for use in North America; or (2) a Safety Extra Low Voltage (SELV)/maximum 240 VA available input, certified for use in the country of installation.
3. Slots and openings in the cabinet are provided for ventilation. To ensure reliable operation of the product and to protect it from overheating, these slots and openings must not be blocked or covered.
4. Do not allow anything to rest on the power cord and do not locate the product where persons will walk on the power cord.
5. Do not attempt to install or service this product yourself, as opening or removing covers may expose you to dangerous high voltage points or other risks. Refer all installation and servicing to qualified service personnel.
6. General purpose cables are provided with this product. Special cables, which may be required by the regulatory inspection authority for the installation site, are the responsibility of the customer.
7. When installed in the final configuration, the product must comply with the applicable Safety Standards and regulatory requirements of the country in which it is installed. If necessary, consult with the appropriate regulatory agencies and inspection authorities to ensure compliance.
8. A rare phenomenon can create a voltage potential between the earth grounds of two or more buildings. If products installed in separate buildings are **interconnected**, the voltage potential may cause a hazardous condition. Consult a qualified electrical consultant to determine whether or not this phenomenon exists and, if necessary, implement corrective action prior to interconnecting the products.
9. In addition, if the equipment is to be used with telecommunications circuits, take the following precautions:
 - Never install telephone wiring during a lightning storm.
 - Never install telephone jacks in wet locations unless the jack is specifically designed for wet locations.
 - Never touch uninsulated telephone wires or terminals unless the telephone line has been disconnected at the network interface.
 - Use caution when installing or modifying telephone lines.
 - Avoid using a telephone (other than a cordless type) during an electrical storm. There may be a remote risk of electric shock from lightning.
 - Do not use the telephone to report a gas leak in the vicinity of the leak.

EMI Warnings

WARNING:

This equipment has been tested and found to comply with the limits for a Class A digital device, pursuant to Part 15 of the FCC rules. These limits are designed to provide reasonable protection against harmful interference when the equipment is operated in a commercial environment. This equipment generates, uses, and can radiate radio frequency energy and, if not installed and used in accordance with the instruction manual, may cause harmful interference to radio communications. Operation of this equipment in a residential area is likely to cause harmful interference in which case the user will be required to correct the interference at his own expense.

The authority to operate this equipment is conditioned by the requirements that no modifications will be made to the equipment unless the changes or modifications are expressly approved by Paradyne Corporation.

WARNING:

To Users of Digital Apparatus in Canada:

This Class A digital apparatus meets all requirements of the Canadian interference-causing equipment regulations.

Cet appareil numérique de la classe A respecte toutes les exigences du règlement sur le matériel brouilleur du Canada.

Contents

About This Guide

- Document Purpose and Intended Audience v
- Document Summary v
- Product-Related Documents vi

1 About the Hotwire 8775 Termination Unit

- M/SDSL Overview 1-1
- Hotwire 8775 Termination Unit Features 1-2
- Network Configuration 1-3
- SNMP Management Capabilities 1-4
 - Management Information Base (MIB) Support 1-4
 - SNMP Trap Support 1-4

2 Using the Asynchronous Terminal Interface

- User Interface Access 2-1
- Management Serial Port Settings 2-1
- Logging In to the Hotwire DSLAM 2-2
- Initiating an ATI Session 2-2
- Screen Work Areas 2-5
- Navigating the Screens 2-6
 - Keyboard Keys 2-6
 - Screen Function Keys 2-7
 - Switching Between Screen Work Areas 2-8
- Ending an ATI Session 2-9
- Exiting From the DSLAM Session 2-9

3 Initial Startup and Configuration

- Overview 3-1
- Entering Identity Information 3-2
- Configuring the Hotwire 8775 Termination Unit 3-3
 - Configuration Options 3-3
- Accessing and Displaying Configuration Options 3-4
- Configuration Edit/Display 3-5
- Disabling AutoRate 3-6
- Configuration Loader 3-7
- Saving Configuration Options 3-9
- Restoring Access to the User Interface 3-10
- Download Code 3-10

4 Monitoring the Hotwire 8775 Termination Unit

- What to Monitor 4-1
- Viewing System and Test Status 4-2
 - Health and Status Messages 4-3
 - Self-Test Results Messages 4-5
 - Test Status Messages 4-5
- Viewing Network Error Statistics 4-6
- Viewing Network Performance Statistics 4-7
- Viewing LED Status 4-9
- Hotwire 8775 Termination Unit LEDs 4-10

5 Testing

- Accessing the Test Menu 5-1
- Running Network Tests 5-2
 - Line Loopback 5-3
 - Repeater Loopback 5-4
 - Remote Send Line Loopback 5-5
 - Send and Monitor 511 5-6
- Running SYNC Data Port Tests 5-7
 - Data Terminal Loopback 5-8
 - Data Channel Loopback 5-9
 - Send Remote Data Channel Loopback 5-10
- Device Tests 5-11
 - Lamp Test 5-11
- Ending an Active Test 5-12

6 Messages and Troubleshooting

- Overview 6-1
- Configuring SNMP Traps 6-2
- Device Messages 6-3
- Troubleshooting 6-5

7 Security

- Overview 7-1
- ATI Access Levels 7-2
- Creating a Login 7-3
- Deleting a Login 7-4
- Controlling SNMP Access 7-5
 - Assigning SNMP Community Names and Access Types 7-5
 - Limiting SNMP Access through the IP Addresses of the Managers . 7-5

8 IP Addressing

- Selecting an IP Addressing Scheme 8-1
 - Configurations Not Running IP Conservative Software 8-1
 - All Configurations 8-1
- IP Addressing Example 8-2

A Configuration Option Tables

- Overview A-1
- Network Interface Options Menu A-2
- Synchronous Data Port Options Menu A-4
- Copy Ports Menu A-7
- System Options Menu A-8
- Management and Communication Options Menu A-9
 - Telnet Sessions Options A-9
 - General SNMP Management Options A-11
 - SNMP NMS Security Options A-12
 - SNMP Traps Options A-13

B Standards Compliance for SNMP Traps

■ SNMP Traps	B-1
warmStart	B-1
authenticationFailure	B-1
linkUp and linkDown	B-2
■ Enterprise-Specific Traps	B-3

C Cables and Pin Assignments

■ Overview	C-1
■ 100-Pin Plug-to-Four DB25 Receptacle EIA-530-A Cable	C-2
■ 100-Pin Plug-to-Four MS34 Receptacle V.35 Cable	C-5
■ 100-Pin Plug-to-Four DB37 Receptacle RS-449 Cable	C-8
■ 100-Pin Plug-to-Four DB15 Receptacle X.21 Cable	C-11

D Technical Specifications

Glossary

Index

About This Guide

Document Purpose and Intended Audience

This guide contains information needed to set up, configure, and operate the 4-port Hotwire 8775 Multirate/Symmetric Digital Subscriber Line (M/SDSL) Termination Unit and is intended for installers and operators.

Document Summary

Section	Description
Chapter 1	<i>About the Hotwire 8775 Termination Unit.</i> Describes the Hotwire 8775 Termination Unit's features and capabilities.
Chapter 2	<i>Using the Asynchronous Terminal Interface.</i> Provides instructions for accessing the user interface and navigating the screens.
Chapter 3	<i>Initial Startup and Configuration.</i> Provides procedures for setting up the user interface and configuring the unit.
Chapter 4	<i>Monitoring the Hotwire 8775 Termination Unit.</i> Describes using the LEDs, status, and network statistics to monitor the unit.
Chapter 5	<i>Testing.</i> Provides information about available tests and test setup.
Chapter 6	<i>Messages and Troubleshooting.</i> Provides information on SNMP traps, device messages, and troubleshooting.
Chapter 7	<i>Security.</i> Presents procedures for creating a login, setting the effective access levels, and controlling SNMP access.
Chapter 8	<i>IP Addressing.</i> Provides information and examples regarding IP addresses.

Section	Description
Appendix A	<i>Configuration Option Tables.</i> Contains all configuration options, default settings, and possible settings.
Appendix B	<i>Standards Compliance for SNMP Traps.</i> Contains SNMP trap compliance information.
Appendix C	<i>Cables and Pin Assignments.</i> Contains connector and interface information.
Appendix D	<i>Technical Specifications.</i> Contains physical and regulatory specifications, network and port interfaces, power consumption values, and accessory part numbers.
Glossary	Defines acronyms and terms used in this document.
Index	Lists key terms, acronyms, concepts, and sections in alphabetical order.

Product-Related Documents

Document Number	Document Title
7975-A2-GB20	<i>Hotwire 7975 M/SDSL Standalone Termination Unit User's Guide</i>
8000-A2-GB22	<i>Hotwire Management Communications Controller (MCC) Card, IP Conservative, User's Guide</i>
8000-A2-GB29	<i>Hotwire Management Communications Controller (MCC) Card User's Guide</i>
8600-A2-GN20	<i>Hotwire 8600 Digital Subscriber Line Access Multiplexer (DSLAM) Installation Guide</i>
8610-A2-GN10	<i>Hotwire 8610 DSLAM Installation Instructions</i>
8775-A2-GZ40	<i>Hotwire 8775 M/SDSL Termination Unit Installation Instructions</i>
8800-A2-GN21	<i>Hotwire 8800 Digital Subscriber Line Access Multiplexer (DSLAM) Installation Guide</i>
8810-A2-GN11	<i>Hotwire 8810 DSLAM Installation Instructions</i>

Contact your sales or service representative to order additional product documentation.

Paradyne documents are also available on the World Wide Web at www.paradyne.com. Select *Library* → *Technical Manuals*.

About the Hotwire 8775 Termination Unit

1

M/SDSL Overview

Hotwire® products can transport data at full (2.048 Mbps) or fractional payload rates over a 2-wire, full-duplex circuit over varying distances based on the conditions of the 2-wire loop. Examples include support for router, multiplexer and PBX connections at 128 kbps, with distances exceeding 29,000 feet (8.9 km) on 24 gauge (.5 mm) cable, or up to 15,000 feet (4.6 km).

Hotwire Multirate/Symmetrical Digital Subscriber Line (M/SDSL) products maximize customer service areas by varying the DSL line rate. This ensures symmetric DSL connectivity over a wide range of telephone line distances and transmission line qualities.

Hotwire M/SDSL is equipped with an automatic configuration capability that reduces the M/SDSL installation process to a simple plug and play mode. Simply connecting the units to the line automatically configures the customer for the maximum data rate supported by the local loop. M/SDSL units can also be configured at fixed line speeds to achieve maximum distances.

Hotwire 8775 Termination Unit Features

The 4-port Hotwire 8775 M/SDSL Termination Unit is a circuit board mounted in a Hotwire 8600 Series or 8800 Series Digital Subscriber Line Access Multiplexer (DSLAM) and used to transport signals at high speeds over a twisted-pair connection.

The Hotwire 8775 Termination Unit offers these standard features:

- **AutoRate Capability.** Provides automatic configuration of line speed and data rate upon connection.
- **Embedded Operations Channel (EOC).** Provides remote management via SNMP or Telnet session capability over the M/SDSL network.
- **Asynchronous Terminal Interface (ATI).** Provides a menu-driven VT100-compatible terminal interface for configuring and managing the unit locally or remotely by Telnet session.
- **Local Management.** Provides local management using the Management Communications Card (MCC) with a:
 - Terminal or PC via the Management Serial port of the DSLAM
 - Network Management System (NMS) via the Management MCC port of the 8600 Series DSLAM or 10BaseT port of the 8800 Series DSLAM
- **Remote Management.** Provides remote management:
 - Out-of-band, using an external modem through the Management Serial port of the DSLAM
 - Using SNMP or Telnet through the 10BaseT port or the Internal Management Channel (IMC)
 - Via Telnet over the EOC
- **Alarm Indication.** Activates front panel LEDs.
- **Diagnostics.** Provides the capability to diagnose device and network problems and perform tests, including digital loopbacks, pattern tests, and self-test.
- **Device and Test Monitoring.** Provides the capability of tracking and evaluating the unit's operation, including health and status, and error-rate monitoring.

Network Configuration

Figure 1-1 shows a network application using a Hotwire 8775 M/SDSL Termination Unit for access concentration in a central office (CO). A frame relay switch and a router are connected, through the termination unit, to partner units supporting a host or router, and frame relay encapsulated or unframed data.

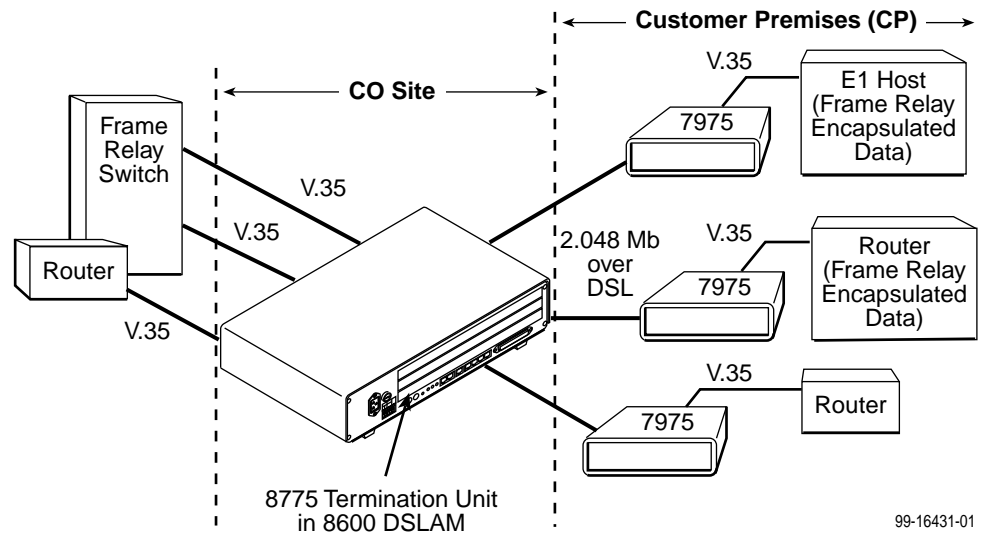

99-16431-01

Figure 1-1. Sample CO-to-CP Configuration

Figure 1-2 shows Hotwire termination units used to distribute T1 lines over a campus.

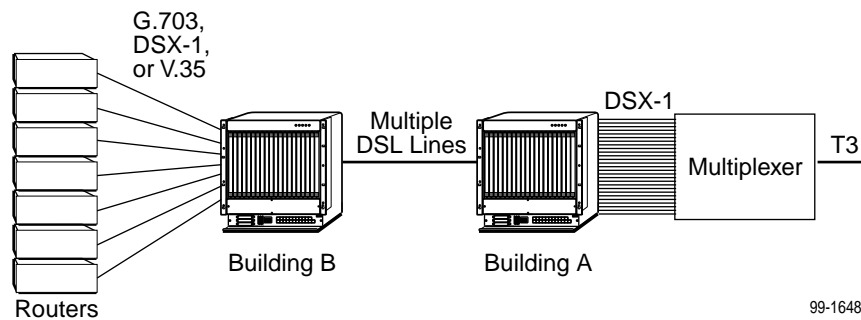

99-16489

Figure 1-2. Sample Campus Configuration

Using the Asynchronous Terminal Interface

2

User Interface Access

You can communicate with the asynchronous terminal interface (ATI) using one of the following methods:

- Direct connection through the Management Serial port of the DSLAM (locally or via an external modem).
- Telnet session using a Network Management System (NMS) connected to a LAN/WAN port on the DSLAM.
- Telnet session through the Embedded Operations Channel (EOC).

NOTE:

Only one asynchronous terminal interface session can be active at a time, and another user's session cannot be forced to end. To automatically log out a user due to inactivity, enable the Inactivity Timeout option (see Table A-5, [Telnet Sessions Options](#), in Appendix A, *Configuration Option Tables*).

Security can limit ATI access several ways. To set up security or a login ID, refer to Chapter 7, [Security](#).

Management Serial Port Settings

Ensure that the device you connect communicates using these settings:

- Data rate set to 9.6 kbps.
- Character length set to 8.
- Parity set to None.
- Stop Bits set to 1.

Refer to the installation document for your DSLAM.

Logging In to the Hotwire DSLAM

You can log in to the Hotwire DSLAM system using either a local VT100-compatible terminal or a remote Telnet connection.

After you enter your user ID and password, the system displays the Hotwire Chassis Main Menu. See your Management Communications Controller (MCC) documentation for information about selecting the unit from the MCC card selection screen.

Initiating an ATI Session

The Main Menu screen is displayed on the screen unless a login ID and password is required or the ATI is already in use.

If the ATI is already in use, the message **connection refused** is sent to a terminal attempting Telnet access.

If security is enabled on the Hotwire 8775 Termination Unit and you used Telnet to access it directly (you did not log in through the MCC), the system prompts you for a login ID and password.

```
Login                               Hotwire
Slot: 4                             Model: 8775

                                LOGIN

          Login ID:  _____
          Enter Password:  _____

-----
Ctrl-a to access these functions                                Exit
```

If you enter an invalid login ID and password three times, the Telnet session closes or the terminal connection returns to an idle state. Refer to Chapter 7, *Security*. If you enter a valid login ID and password, the Main Menu appears.

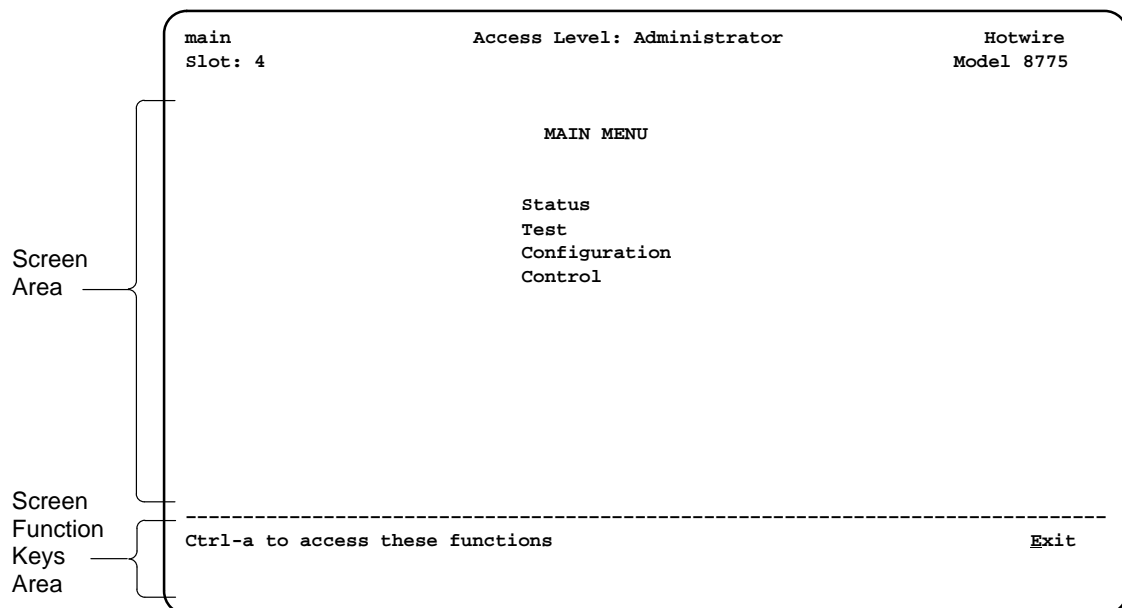

Entry to all of the termination unit's tasks begins at the Main Menu screen. The four branches of the Hotwire 8775 Main menu are as follows:

Select ...	To ...
Status	View system status, diagnostic test results, statistics, LEDs, and device identity information.
Test	Select, start, stop and cancel tests for the unit's interfaces.
Configuration	Display and edit the configuration options.
Control	Change the device identity, administer logins, download new firmware, or initiate a power-up reset of the unit.

What appears on the screens depends on your:

- **Current configuration** – How your unit is currently configured.
- **Effective security access level** – An access level that is typically set by the system administrator for each interface and each user.
- **Data selection criteria** – What you entered in previous screens.

The following illustration shows the paths to the different ATI screens.

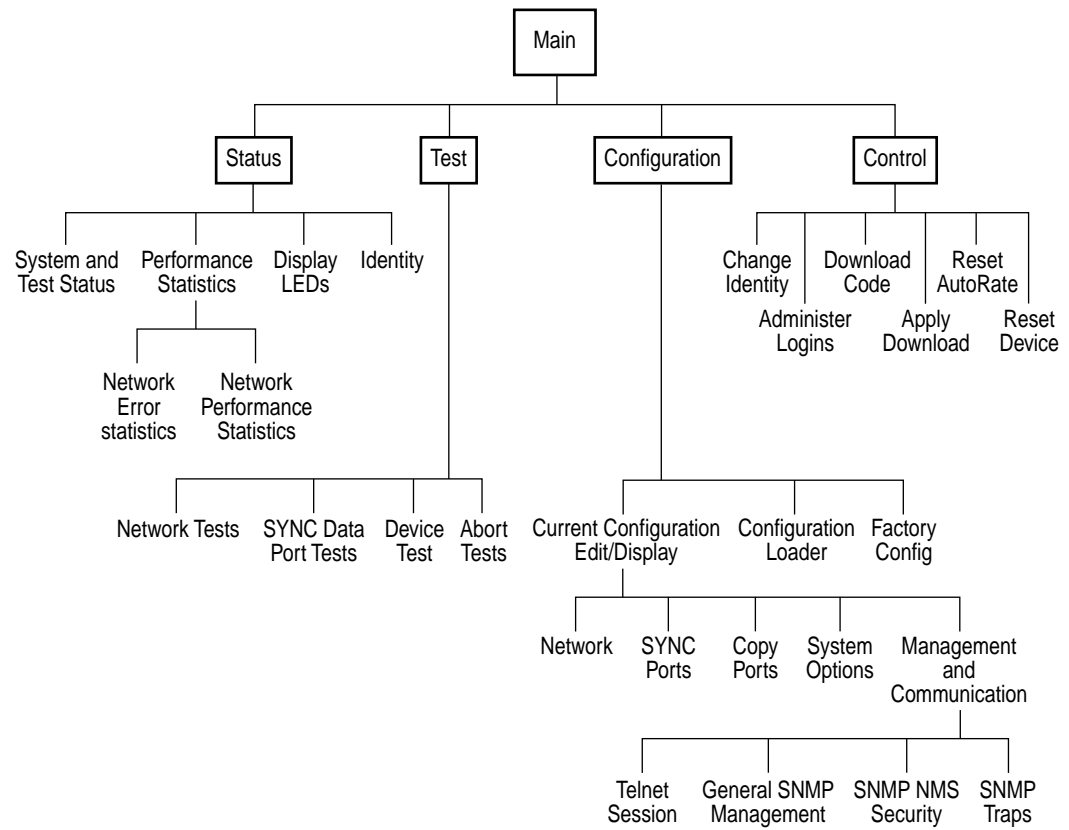

99-16296a

Screen Work Areas

There are two user work areas:

- **Screen area** – This is the area above the dotted line that provides the menu path, menus, and input fields.

The menu path appears as the first line on the screen. In this manual, the menu path is presented as a menu selection sequence with the names of the screens:

Main Menu → Configuration → Load Configuration From → Network Interface Options

- **Screen function key area** – This is the area below the dotted line that lists function keys specific to the screen, field value choices, and system messages.

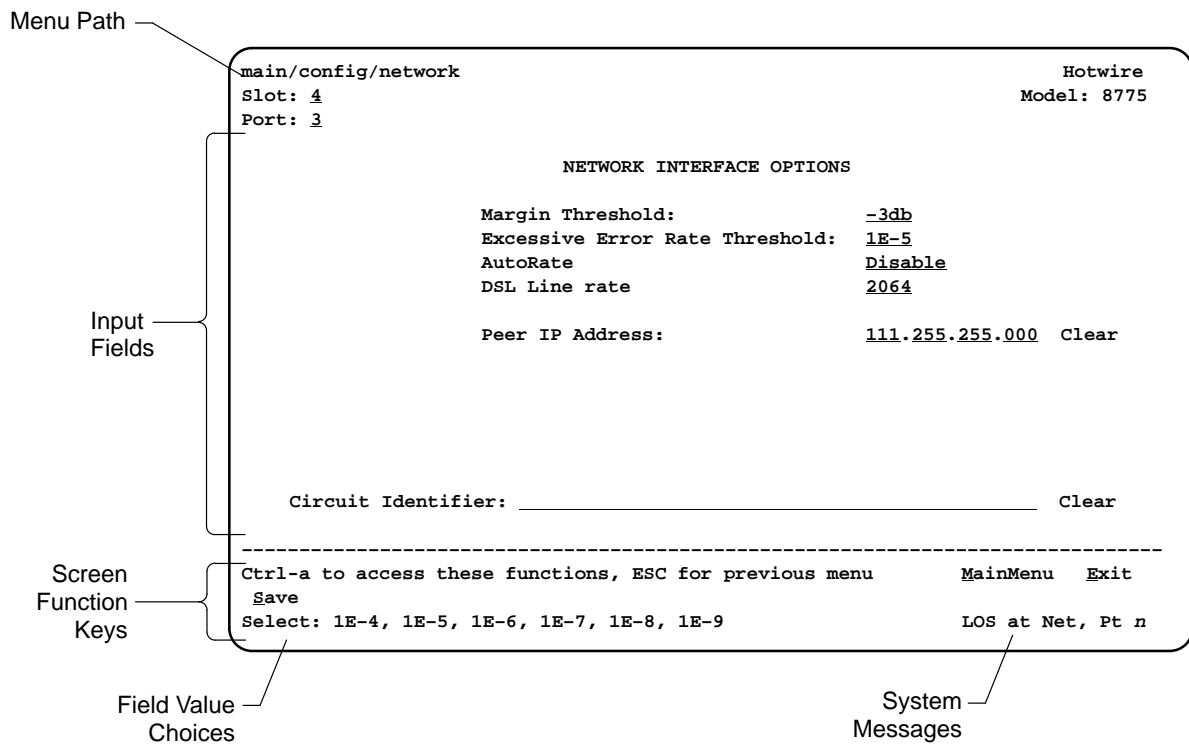

Navigating the Screens

You can navigate the screens by:

- Using keyboard keys
- Using screen function keys
- Switching between the two screen work areas

Keyboard Keys

Use the following keyboard keys to navigate within the screen.

Press . . .	To . . .
Ctrl-a	Move cursor between the screen area and the screen function keys area below the dotted line at the bottom of the screen.
Esc	Return to the previous screen.
Tab	Move cursor to the next field on the screen.
Backspace	Move cursor to the previous field on the screen.
Enter	Accept entry or display valid options on the last row of the screen when pressed before entering data or after entering invalid data.
Ctrl-k	Tab backwards (move cursor one field to the left).
Spacebar	Select the next valid value for the field.
Delete (Del)	Delete character that the cursor is on.
Up Arrow or Ctrl-u	Move cursor up one field within a column on the same screen.
Down Arrow or Ctrl-d	Move cursor down one field within a column on the same screen.
Right Arrow or Ctrl-f	Move cursor one character to the right if in edit mode.
Left Arrow or Ctrl-b	Move cursor one character to the left if in edit mode.
Ctrl-l	Redraw the screen display, clearing information typed in but not yet entered.

► Procedure

To make a menu or field selection:

1. Press the Tab key or the right arrow key to position the cursor on a menu or field selection. Each selection is highlighted as you press the key to move the cursor from position to position.
2. Press Enter. The selected menu or screen appears.
3. Continue Steps 1 and 2 until you reach the screen you want.

The current setting or value appears to the right of the field name. You can enter information into a selected field by:

- Typing in the first letter(s) of a field value or command.
- Switching from the screen area to the screen function area below the dotted line and selecting or entering the designated screen function key.

If a field is blank and the Field Values screen area displays valid selections, press the spacebar and the first valid value for the field will appear. Continue pressing the spacebar to scroll through other valid values.

Screen Function Keys

All screen function keys located below the dotted line operate the same way (upper- or lowercase) throughout the screens.

For the screen function . . .	Select . . .	And press Enter to . . .
Clr <u>F</u> ar	F or f	Clear far-end network statistics and refresh the screen.
Clr <u>N</u> ear	N or n	Clear near-end network statistics and refresh the screen.
De <u>L</u> ete	L or l	Delete data.
<u>E</u> xit	E or e	Terminate the asynchronous terminal session.
<u>M</u> ainMenu	M or m	Return to the Main Menu screen.
<u>N</u> ew	N or n	Enter new data.
Pg <u>D</u> n	D or d	Display the next page, or group of entries.
Pg <u>U</u> p	U or u	Display the previous page, or group of entries.
<u>R</u> esetMon	R or r	Reset an active Monitor 511 test counter to zero.
<u>S</u> ave	S or s	Save information.

Switching Between Screen Work Areas

Select Ctrl-a to switch between the two screen work areas to perform all screen functions.

► Procedure

To access the screen function area below the dotted line:

1. Press Ctrl-a to switch from the screen area to the screen function key area below the dotted line.
2. Select either the function's designated (underlined) character or press the Tab key until you reach the desired function key.

Example:

To save the current options, type **s** or **S** (Save).

3. Press Enter. The function is performed.
4. To return to the screen area above the dotted line, press Ctrl-a again.

```
main/config/network                               Hotwire
Slot: 4                                           Model: 8775
Port: 3

                                NETWORK INTERFACE OPTIONS

Margin Threshold:                -3db
Excessive Error Rate Threshold: 1E-5
AutoRate                         Disable
DSL Line rate                     2064

Peer IP Address:                 111.255.255.000 Clear

Circuit Identifier: _____ Clear

-----
Ctrl-a to access these functions, ESC for previous menu   MainMenu Exit
Save
```

Ending an ATI Session

Use the Exit function key from any screen to terminate the session.

► Procedure

To end a session with the asynchronous terminal interface:

1. Press Ctrl-a to go to the screen function key area below the dotted line.
2. Save changes if required. A confirmation message appears if you have made but not saved changes to your configuration.
3. Tab to Exit (or type **e** or **E**) and press Enter. If you have accessed the card through the MCC, the Hotwire Chassis Card Selection menu appears.

Exiting From the DSLAM Session

You can manually log out of the system or, after five minutes of inactivity, the system will automatically log you out if the inactivity time-out option is enabled.

► Procedure

To manually exit from the Hotwire DSLAM system:

1. Return to the Hotwire Chassis Main Menu by pressing Ctrl-z or Ctrl-a from the Hotwire Chassis Card Selection menu.
2. From the Hotwire Chassis Main Menu, select Logout.
The system exits from the current login session on the Hotwire DSLAM.

Initial Startup and Configuration

3

Overview

This chapter provides instructions on how to access the system for the first time and perform initial setup procedures. These procedures include:

- Providing initial **unit identity** information or changing existing identity information.
- Accessing and displaying the current or factory default **configuration options**.
- Modifying current configuration options using the **Configuration Edit/Display** menu.
- **Configuring AutoRate**
- **Saving** your configuration option changes.
- **Restoring access** to the user interface in the event it is lost.
- **Downloading firmware** from a TFTP server.

Entering Identity Information

After accessing your unit for the first time, use the Change Identity screen to determine SNMP administrative system information that will be displayed on the Identity screen of the Status branch. To access the Card Identity screen, follow this menu selection sequence:

Main Menu → Control → Change Identity

```

main/control/change_identity                               Hotwire
Slot: 4                                                    Model: 8775

                                IDENTITY

System Name:      111QJ98-001_____ Clear
System Location:  Bldg. A412, 2nd Floor, Left cabinet_____ Clear
System Contact:   C. Parker 800-727-2396 pager 888-555-1212 Clear

-----
Ctrl-a to access these functions, ESC for previous menu   MainMenu  Exit
Save

```

The three System entry fields are alphanumeric and provide 128 characters for each field. The System entries appear on the Identity display as shown above. The SNMP System entry fields are:

- **System Name:** The general SNMP system name.
- **System Location:** The physical location of the SNMP-managed device.
- **System Contact:** Identification information, such as contact name, phone number, or mailing address.

Valid entry values are any printable ASCII character. ASCII printable characters include:

- Numeric 0–9
- Upper or lower case A–Z
- Space
- All ASCII symbols except the caret (^)

Select Clear to reset a field to a null value.

► Procedure

To enter Change Identity screen information:

1. Position the cursor in the System Name field. Enter a name unique in your network to identify the SNMP managed node (or unit)
The maximum length of System Name is 128 characters.
2. Position the cursor in the System Location field. Enter the physical location of the unit.
The maximum length of System Location is 128 characters.
3. Position the cursor in the System Contact field. Enter the name and contact information for the person responsible for the unit.
The maximum length of System Contact is 128 characters.
4. Press Ctrl-a to switch to the screen function key area below the dotted line.
5. Select Save and press Enter.

Configuring the Hotwire 8775 Termination Unit

Configuration option settings determine how the Hotwire 8775 Termination Unit operates. Use the Configuration branch of the Hotwire 8775 Termination Unit menu to display or change configuration option settings.

Configuration Options

The Hotwire 8775 Termination Unit is shipped with factory settings in the Default Factory Configuration area. You can find default information by:

- Referring to Appendix A, *Configuration Option Tables*.
- Accessing the Configuration branch of the Hotwire 8775 Termination Unit menu.

The Hotwire 8775 Termination Unit has two sets of configuration option settings. The Current Configuration matches the Default Factory Configuration until modified and saved by the user.

Configuration Option Area	Configuration Option Set
Current Configuration	The unit's active set of configuration options.
Default Factory Configuration	A read-only configuration area containing the factory default configuration options.

If the factory default settings do not support your network's configuration, customize the configuration options for your application.

Accessing and Displaying Configuration Options

To display the configuration options, you must first load a configuration option set into the edit area.

To load a configuration option set into the configuration edit area, follow this menu selection sequence:

Main Menu → Configuration (Load Configuration From)

```

main/configuration                               Hotwire
Slot: 4                                           Model: 8775

                                LOAD CONFIGURATION FROM:

                                Current Configuration
                                Configuration Loader
                                Default Factory Configuration

-----
Ctrl-a to access these functions, ESC for previous menu      MainMenu  Exit

```

Make a selection by placing the cursor at your choice and pressing Enter.

If you select ...	Then ...
Current Configuration	The selected configuration option set is loaded and the Configuration Edit/Display menu screen appears.
Configuration Loader	The Configuration Loader screen is displayed allowing you to upload or download configurations from a TFTP server.
Default Factory Configuration	The selected configuration option set is loaded and the Configuration Edit/Display menu screen appears.

Configuration Edit/Display

The Configuration Edit/Display screen appears when the current, customer, or default configuration is loaded and allows groups of configuration options to be displayed. To access the Configuration Edit/Display screen, follow this menu selection sequence:

Main Menu → Configuration → Current Configuration

– or –

Main Menu → Configuration → Default Factory Configuration

```

main/config/edit                               Hotwire
Slot: 4                                       Model: 8775

                                CONFIGURATION EDIT/DISPLAY

                                Network
                                SYNC Ports
                                Copy Ports
                                System Options
                                Management and Communication

-----
Ctrl-a to access these functions, ESC for previous menu      MainMenu  Exit
Save
  
```

Select ...	To Access the ...	To Configure the ...
Network	Network Interface Options , Table A-1	DSL network interface Ports 1–4.
SYNC Ports	Synchronous Data Port Options , Table A-2	Synchronous DTE interface Ports 1–4.
Copy Ports	Copy Ports Options , Table A-3	DSL network and synchronous DTE interface ports by copying options from port to port.
System Options	System Options , Table A-4	General system options of the unit.
Management and Communication	<ul style="list-style-type: none"> ■ Telnet Sessions Options, Table A-5 ■ General SNMP Management Options, Table A-6 ■ SNMP NMS Security Options, Table A-7 ■ SNMP Traps Options, Table A-8 	Management support of the unit through SNMP and Telnet.

Disabling AutoRate

The M/SDSL AutoRate function is controlled from the Network Interface Options screen and allows you to enable or disable AutoRate. The AutoRate option is only available if the unit is configured as an LTU. To access the Network Interface screen, follow this menu selection sequence:

Main Menu → Configuration → Network

```

main/config/network                               Hotwire
Slot: 4                                           Model: 8775
Port: 1

                                NETWORK INTERFACE OPTIONS

Margin Threshold:                               -3db
Excessive Error Rate Threshold:                 1E-5
AutoRate                                         Disable
DSL Line Rate                                   144

Circuit Identifier: _____ Clear

-----
Ctrl-a to access these functions, ESC for previous menu   MainMenu  Exit
Save

```

► Procedure

The AutoRate option defaults to Enable. To disable AutoRate:

1. Position the cursor in the AutoRate field and press the spacebar.
The AutoRate field toggles to Disable and the DSL Line Rate field appears.
2. Enter a DSL Line Rate and press Enter.
Your payload rate is set to a default value determined by your LTU DSL Line Rate. Use Table 3-1, [Selectable Payload Rates When AutoRate Is Disabled](#), to set your DSL Line Rate and Payload Rate.

Table 3-1. Selectable Payload Rates When AutoRate Is Disabled

DSL Line Rate	Selectable Payload Rates (default in boldface type)							
144	128	64						
272	256	192						
400	384	320						
528	512	448						
784	768	704	640	576				
1040	1024	960	896	832				
1552	1536	1472	1408	1344	1280	1216	1152	1088
2064	2048	1984	1920	1856	1792	1728	1664	1600

Configuration Loader

The Configuration Loader screen allows you to upload configurations to and download configurations from a TFTP server. To access the Configuration Loader screen, follow this menu selection sequence:

Main Menu → Configuration → Configuration Loader

```

main/config/config_loader                               Hotwire
Slot: 4                                                Model: 8775

                                CONFIGURATION LOADER

Image File Name: _____ Clear
TFTP Server IP Address: 000.000.000.000               Clear
TFTP Transfer Direction: Download from Server
Destination: DSL1

Start Transfer: Yes

Packets Sent: 0000000
Packets Received: 0000000
Bytes Sent: 0000000
Bytes Received: 0000000
Transfer Status: Transfer Pending

Activate new configuration? No_

-----
Ctrl-a to access these functions, ESC for previous menu      MainMenu  Exit

```

► Procedure

To upload or download a configuration:

1. Position the cursor in the Image File Name field. Type the name of the file to be downloaded, or the name to be used for the file to be uploaded.

The file name may be a regular path name expression of directory names separated by a forward slash (/) ending with the file name. The total path name length can be up to 128 characters.

- *DOS machine*: If the TFTP server is hosted by a DOS machine, then directory and filenames must consist of eight or less characters with an optional suffix of up to three characters. The system will automatically upload the configuration file and create directories and file names as needed.
- *UNIX machine*: If your server is hosted by a UNIX machine, the configuration file you name must already exist. It will not be created on the UNIX system by the TFTP server. It is critical that you work with your system administrator to plan the naming conventions for directories, filenames, and permissions so that anyone using the system has read and write permissions.

2. Position the cursor in the TFTP Server IP Address field. Enter the TFTP server IP address.

The first three digits of the IP address cannot be 000 or greater than 223.

3. Position the cursor in the TFTP Transfer Direction field. Use the spacebar to select Download from Server or Upload to Server.

4. Position the cursor in the Destination field. Use the spacebar to select a network destination for the TFTP server. Select DSL n if the TFTP server destination is the DSL link or IMC if the TFTP destination is the Management port of the MCC. (Destination is not available and IMC is assumed if the DSL mode is LTU.)

5. Position the cursor at the Start Transfer field. Use the spacebar to select Yes. Press Enter.

When the data transfer is complete, the Transfer Status field changes to **Completed successfully**.

6. Position the cursor at the **Activate new configuration?** prompt and select Yes to activate a new downloaded configuration. Press Enter.

NOTE:

The following options are not changed:

- DSL Mode and Telnet Session configuration options
- Peer IP address

You must change these settings with the appropriate configuration menus after the new configuration is activated. See Table A-1, [Network Interface Options](#), Table A-4, [System Options](#), and Table A-5, [Telnet Sessions Options](#), in Appendix A, *Configuration Option Tables*.

Saving Configuration Options

When changes are made to the configuration options through the Configuration Edit/Display branch, the changes must be saved to take effect. Use the Save key or Save Configuration screen.

► Procedure

To save configuration options changes:

1. Press Ctrl-a to switch to the screen function key area below the dotted line.
2. Select Save and press Enter.

NOTE:

When Exit is selected before Save, or Save has been selected from any menu in the Configuration/Edit branch, a Save Configuration screen appears requiring a Yes or No response.

```

main/config/saveprompt                               Hotwire
Slot: 4                                             Model: 8775

                SAVE CONFIGURATION

                Save Changes? No_

                WARNING:

                An answer of "yes" will cause the system
                to reset as if it had been powered off and on!

-----
Ctrl-a to access these functions, ESC for previous menu      MainMenu  Exit
Command Complete
  
```

If the Telnet Session configuration option is changed, a message displays on the Save Configuration screen warning that an answer of Yes will cause the Telnet session to disconnect. Do not answer Yes unless you are prepared to disconnect.

If the DSL Mode configuration option is changed, the Save Configuration screen bears the warning that an answer of Yes will cause the system to reset. Do not answer Yes unless you are prepared to reset.

If you select ...	Then ...
Yes	The configuration is saved.
No	The Main Menu appears and changes are not saved.

Restoring Access to the User Interface

Improper configuration of the unit could render the user interface inaccessible. If this occurs, access can be restored using the MCC.

► Procedure

To reset the DSL Card:

1. Select *Configuration* → *DSL Cards* → *Reset Slot*.
2. Enter **DSLnn**, where *nn* is the slot number for the DSL card you wish to reset.
3. Enter **Y** at the prompt to confirm.

NOTE:

When you enter Y, all data connectivity is interrupted.

Download Code

The Download Code screen allows you to download firmware from a TFTP server. To access the Download Code screen, follow this menu selection sequence:

Main Menu → *Control* → *Download Code*

```
main/control/download_code                               Hotwire
Slot: 4                                                  Model: 8775

                                DOWNLOAD CODE

Image File Name: _____ Clear
TFTP Server IP Address: 000.000.000.000                Clear
Destination: DSL1
Immediately Apply Download: No
Start Transfer: Yes

Packets Sent: 0000000
Packets Received: 0000000
Bytes Sent: 0000000
Bytes Received: 0000000
Transfer Status: Transfer Pending

-----
Ctrl-a to access these functions, ESC for previous menu      MainMenu  Exit
```

► Procedure

To download firmware:

1. Position the cursor in the Image File Name field. Type the name of the file to be downloaded.
The file name may be a regular path name expression of directory names separated by a forward slash (/) ending with the file name. The total path name length can be up to 128 characters.
2. Position the cursor in the TFTP Server IP Address field. Enter the TFTP server IP address.
The first three digits of the IP address cannot be 000 or greater than 223.
3. Position the cursor in the Immediately Apply Download field. If you would like the download to be effective immediately, select **Yes**.
4. Position the cursor at the Start Transfer field. Use the spacebar to select Yes. Press Enter.
When the data transfer is complete, the Transfer Status field changes to **Completed successfully**.

If you specified **No** (the default) in the Immediately Apply Download field in Step 3 above, you must now apply the download.

► Procedure

To apply the downloaded firmware:

1. Press the Escape key to return to the Control menu. Select Apply Download.
2. On the Apply Download screen, type **Yes** to reset the card and activate the code.

Monitoring the Hotwire 8775 Termination Unit

4

What to Monitor

This chapter presents information on how to access and monitor unit status and performance statistics on the network. You can monitor Hotwire 8775 Termination Unit operations by viewing:

- **System and Test Status** screen
 - Highest priority **Health and Status** message on the last line of all screens
 - **Self-test results** messages
 - **Test status** messages
- **Network Error Statistics** screen
- **Network Performance Statistics** screen
- **Display LEDs** screen or **LEDs on the unit's front panel**

Viewing System and Test Status

To view System and Test Status information, follow this menu selection sequence:

Main Menu → Status → System and Test Status

```

main/status/system
Slot: 4
Hotwire
Model: 8775
SYSTEM AND TEST STATUS
Page 1 of 1

HEALTH AND STATUS          SELF-TEST RESULTS      TEST STATUS
-----
LOS at Net, Pt n           CPU Failed              No Test Active
OOF at Net, Pt n           Device Failed           LLB Test Active, Pt n
EER at Net, Pt n           Net DSL Failed, Pt n   RLB Test Active, Pt n
SYNC Pt Down, Pt n         SYNC Pt Failed, Pt n   DTLB Test Active, Pt n
Net Margin Threshold, Pt n Memory Failed           DCLB Test Active, Pt n
Fallback Rate, Pt n        Failure xxxxxxxx       511 Test Active, Pt n
Device Failed yyyyyyyy     Passed                  Lamp Test Active
Download Failed
Net Com Link Down
Mismatch Rate, Pt n

-----
ESC for previous menu      MainMenu  Exit

```

The System and Test Status screen has three sections:

- **Health and Status** – Displays messages in priority order (highest to lowest). Refer to Table 4-1, [Health and Status Messages](#).
- **Self-Test Results** – Results of the Diagnostic test run on the device itself. Refer to Table 4-2, [Self-Test Results Messages](#).
- **Test Status** – Currently active tests. Refer to Table 4-3, [Test Status Messages](#).

Health and Status Messages

The following messages appear in the first column of the System and Test Status screen. The highest priority Health and Status message also appears on all ATI screens on the bottom right.

Table 4-1. Health and Status Messages (1 of 2)

Message	What Message Indicates	What To Do
System Operational	There are no problems detected.	
LOS at Net, Pt <i>n</i>	An LOS (Loss Of Signal) condition has been detected on the network interface. No signal is being received on Port <i>n</i> , possibly due to a local network problem.	<ol style="list-style-type: none"> 1. Verify that the network cable is securely attached at both ends. 2. Verify proper LTU and NTU configuration. 3. Contact network provider.
OOF at Net, Pt <i>n</i>	Three consecutive frame synchronization bits were in error.	<ol style="list-style-type: none"> 1. Check the Transmit Clock Source configuration options. Do not set both the local and remote unit to Internal, External, or Loop timing. 2. If the unit is configured as an LTU, verify that Transmit Clock Source is set to External and that the synchronous port is providing valid clocking. 3. Check the Network Performance Statistics screen for possible line impairments. 4. Set the unit to run at a lower DSL line rate. 5. Contact network provider.
EER at Net, Pt <i>n</i>	An EER (Excessive Error Rate) condition has been detected on the network interface at Port <i>n</i> . The condition is cleared when the error rate falls below the threshold value currently configured.	<ol style="list-style-type: none"> 1. Ignore condition if a Send and Monitor 511 test is active. 2. Check the Network Performance Statistics screen for possible line impairments. 3. Set the unit to run at a lower DSL line rate. 4. Contact network provider.
SYNC Pt Down, Pt <i>n</i>	The interchange circuits for Port <i>n</i> are configured to monitor DTR and/or RTS, and a monitored lead is not asserted.	Verify that the DTE is providing the monitored signals.
Net Margin Threshold, Pt <i>n</i>	The signal-to-noise margin has fallen below the configured threshold for Port <i>n</i> .	<ol style="list-style-type: none"> 1. Check the Network Performance Statistics screen for possible line impairments. 2. Set the unit to run at a lower DSL line rate. 3. Contact network provider.

Table 4-1. Health and Status Messages (2 of 2)

Message	What Message Indicates	What To Do
Fallback Rate, Pt <i>n</i>	The LTU, set to AutoRate enable, had a LOS when the line was restored and resynched at a lower rate.	<ol style="list-style-type: none"> 1. Ignore if the rate is acceptable. 2. Reset the line using the Reset AutoRate selection of the Control menu. 3. Change to a fixed rate if the fallback rate is unacceptable. 4. Contact network provider.
Device Failed <i>yyyyyyyy</i>	An internal error has been detected by the operating software. <i>yyyyyyyy</i> indicates the 8-digit hexadecimal failure code.	<ol style="list-style-type: none"> 1. Provide the 8-digit failure code shown (<i>yyyyyyyy</i>) to your service representative. 2. Reset the Hotwire 8775 Termination Unit to clear the condition and message.
Download Failed	A firmware download was interrupted.	Repeat the download.
Net Com Link Down	The network communication link is down and the NMS cannot communicate with the unit.	<ol style="list-style-type: none"> 1. Verify that the network cable is securely attached at both ends. 2. Verify that the link protocol for the COM port is configured correctly.
Mismatch Rate, Pt <i>n</i>	The LTU, set to a fixed rate, is attempting to operate at a speed higher than what the NTU is capable of.	Determine why the NTU does not support the specified rate.

Self-Test Results Messages

The results of the last power-on or reset self-test appear in the middle column of the System and Test Status screen.

Table 4-2. Self-Test Results Messages

Message	What Message Indicates	What To Do
CPU Failed	The CPU failed internal testing.	1. Reset the unit and try again. 2. Call your service representative for assistance.
DeviceFailed	One or more of the unit's integrated circuit chips has failed device-level testing.	
Net DSL Failed, Pt <i>n</i>	The unit failed to loop data on the network DSL circuit of Port <i>n</i> .	1. Reset the unit and try again. 2. Call your service representative for assistance.
SYNC Pt Failed, Pt <i>n</i>	The unit failed to internally loop data on the synchronous Port <i>n</i> .	
Memory Failed	The unit failed memory verification.	
Failure xxxxxxx	An internal failure occurred. (xxxxxxx represents an 8-digit hexadecimal failure code for use by service personnel.)	Record the failure code and contact your service representative.
Passed	No errors were detected.	

Test Status Messages

The Test Status messages in the following table appear in the right column of the System and Test Status screen.

Table 4-3. Test Status Messages

Test Status Message	Meaning
No Test Active	No tests are currently running.
LLB Test Active, Pt <i>n</i>	A network Line Loopback test is active on Port <i>n</i> .
RLB Test Active, Pt <i>n</i>	A network Repeater Loopback test is active on Port <i>n</i> .
DTLB Test Active, Pt <i>n</i>	A Data Terminal Loopback test is active on Port <i>n</i> .
DCLB Test Active, Pt <i>n</i>	A Data Channel Loopback test is active on Port <i>n</i> .
511 Test Active, Pt <i>n</i>	A 511 Test and Monitor is active on the DSL Port <i>n</i> network interface.
Lamp Test Active	The Lamp Test is active, causing the LEDs on the front panel to light.

Viewing Network Error Statistics

The Hotwire 8775 Termination Unit maintains error statistics on the network DSL interface for each port. Port 1 is the default screen selection.

Statistics are maintained for up to 96 15-minute intervals (24 hours).

To view the Network Error Statistics, follow this menu selection sequence:

Main Menu → Status → Performance → Network Error Statistics

```

main/status/performance/net_error                               Hotwire
Slot: 4:                                                       Model: 8775
Port: 3                                                         NETWORK ERROR STATISTICS

Current Interval Timer: 2                                     Error Events Counter: 34
-----
      ---ES---      ---SES---      --FEBE--      -Complete-
        Near Far        Near Far        Near Far        Near Far
Current Int: 000 000        000 000        000 000        Yes No
Interval 01 000 000        000 000        000 000        Yes Yes
Interval 02 000 000        000 000        000 000        Yes Yes
Interval 03 000 000        000 000        000 000        Yes Yes
Interval 04 000 000        000 000        000 000        Yes Yes
Interval 05 000 000        000 000        000 000        Yes Yes
Interval 06 000 000        000 000        000 000        Yes Yes
Interval 07 000 000        000 000        000 000        Yes Yes

Worst Interval: 24 09        14 08        18 18
Near Tot(valid): 00010        00000        00000
Far Tot(valid): 00010        00000        00000
-----
Ctrl-a to access these functions, ESC for previous menu      MainMenu  Exit
PgUp      PgDn      ClrNear      ClrFar

```

Select a port 1–4 to view error statistics for the port. The default port is 1. Use the virtual function keys to page through the intervals and clear statistics.

Network Error Statistics are collected for all ports for:

- **ES (Errored Seconds):** Seconds during which one or more error events occurred.
- **SES (Severely Errored Seconds):** Seconds during which 320 or more cyclic redundancy check (CRC) error events occurred.
- **FEBE (Far-End Block Errors):** Errors reported by the remote equipment.
- **Complete:** Whether the interval register contains data for all 900 seconds of the interval.

Use the virtual function keys to page through the intervals and clear statistics.

This Field . . .	Contains . . .
Current Interval Timer	The number of seconds which have elapsed in the current 15-minute interval. Maximum value is 900 seconds (15 minutes). This counter resets every 15 minutes.
Error Events Counter	A running total of CRC errors. Range 0–65535. This counter resets when the near-end data is cleared.
Current Int	Performance data for the current 15-minute interval.
Interval xx	Historical performance data for up to 96 15-minute intervals (24 hours).
Worst Interval	The number of the interval with the worst (highest) performance data for both the near- and far-end statistics. If two or more intervals are equal, the oldest interval is displayed.
Near and Far Tot	A running total of the near- and far-end performance statistics.

Viewing Network Performance Statistics

Network performance statistics allow you to monitor the current status of the network DSL operations. Performance statistics can assist you in determining the duration of specific conditions and provide a historical context for problem detection and analysis.

Statistics are maintained for up to 96 15-minute intervals (24 hours).

To view the Network Performance Statistics, follow this menu selection sequence:

Main Menu → Status → Performance → Network Performance Statistics

```

main/status/performance/net_perf
Slot: 4:
Port: 3
Hotwire Model: 8775
NETWORK PERFORMANCE STATISTICS

Current Interval Timer: 002
DSL Line Rate: 2048 kbps
-----
--Mrgn--      --XmtPw-      --RxGn--      -Complete-
Near Far      Near Far      Near Far      Near Far
Current Int: +02 +01      +03 +03      +02 +02      Yes Yes
Interval 01  +02          +03          +02          Yes No
Interval 02  +02 +01      +03 +03      +02 +02      Yes Yes
Interval 03  +02 +01      +03 +03      +02 +02      Yes Yes
Interval 04  +02 +01      +03 +03      +02 +02      Yes Yes
Interval 05  +02 +01      +03 +03      +02 +02      Yes Yes
Interval 06  +02 +01      +03 +03      +02 +02      Yes Yes
Interval 07  +02 +01      +03 +03      +02 +02      Yes Yes
-----
Ctrl-a to access these functions, ESC for previous menu
PgUp   PgDn   ClrNear ClrFar
MainMenu Exit

```

Select a port (1–4) to view performance statistics for the port. The default port is 1. Use the virtual function keys to scroll through the intervals and clear statistics.

Use the virtual function keys to scroll through the intervals and clear statistics.

Network Performance Statistics are collected for all ports for:

- **Mrgn:** Signal to Noise Ratio (SNR) Margin, the amount (in dB) that the Receive signal has exceeded the value needed to maintain a Bit Error Rate (BER) of 10^{-7} or better.
- **XmtPw:** The transmit power level.
- **RxGn:** The receiver gain level.
- **Complete:** Whether the interval register contains data for all 900 seconds of the interval.

This Field . . .	Contains . . .
Current Interval Timer	The number of seconds which have elapsed in the current 15-minute interval. Maximum value is 900 seconds (15 minutes). This counter resets every 15 minutes.
DSL Line Rate	The rate of the DSL line.
Current Int	Performance data for the current 15-minute interval.
Interval xx	Historical performance data for up to 96 15-minute intervals (24 hours).

Viewing LED Status

The status of the Hotwire 8775 Termination Unit LEDs can be viewed locally and remotely on the Display LEDs Status screen.

The 12 LEDs are organized in three groups:

- **General** LEDs display the status of the unit
- **Sync Port** LEDs provide the status of the DTE interface
- **DSL Loop** LEDs display the activity on the DSL network

To view the LED status screen, follow this menu selection sequence:

Main Menu → Status → Display LEDs

```

main/status/leds                               Hotwire
Slot: 4                                         Model: 8775

                                DISPLAY CARD LEDs

                                GENERAL          SYNC PORT          DSL LOOP
-----
                                ALRM:Off      P1:No DTR/RTS          P1:Lnk Up
                                TEST:On       P2:Lnk Up              P2:Startup
                                P3:DCLB      P3:OOF                 P3:OOF
                                P4:Disabled   P4:Lnk Dn              P4:Lnk Dn

-----
                                ESC for previous menu      MainMenu  Exit

```

The LED status display screen is updated every 5 seconds. For information about the meaning of 8775 Termination Unit LEDs, see *Hotwire 8775 Termination Unit LEDs* on page 4-10.

Hotwire 8775 Termination Unit LEDs

The following table describes the meaning and states of the LEDs on the Hotwire 8775 Termination Unit faceplate.

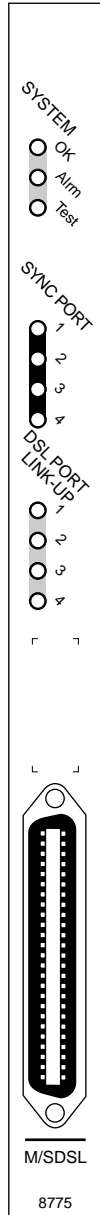

Type	LED	LED is . . .*	Indicating . . .
SYSTEM	OK (Green)	On	Normal operation; card functioning normally.
		Off	No power to card, or card failure.
		Slow Cycling	Unit is in minimum mode and a download is required.
SYSTEM	Alarm (Amber)	On	Device failure, or Power-On Self-Test (POST) is not complete.
		Off	No alarms.
SYSTEM	Test (Amber)	On	Loopback test or 511 test pattern in progress.
		Slow cycling	POST in progress.
		Off	No tests.
SYNC PORT	1, 2, 3, 4 (Green)	On	The port is operational.
SYNC PORT	1, 2, 3, 4 (Green)	Off	No signal on the port, or DTR or RTS is off.
DSL PORT LINK UP	1, 2, 3, 4 (Green)	On	DSL link is up.
		Slow cycling	DSL training in progress.
		Fast cycling	OOF condition.
		Off	DSL link is down.
* Slow Cycling:		LED turns off and on in equal duration once per second.	
Fast Cycling:		LED turns off and on in equal duration 5 times per second.	
Pulsing:		LED turns off momentarily once per second.	

99-15834-01

Testing

5

Accessing the Test Menu

From the Test menu, you can run network tests, data port tests, a lamp test for the front panel LEDs, or abort all tests.

To access the Test menu, follow this menu selection sequence:

Main Menu → Test

```
main/test                                     Hotwire
Slot: 4                                       Model: 8775

                                TEST

                                Network Tests
                                SYNC Data Port Tests
                                Device Tests

                                Abort All Tests

-----
Ctrl-a to access these functions                                     Exit
```

Select ...	To ...
Network Tests	Start and stop tests on the network interface.
SYNC Data Port Tests	Start and stop tests on the DTE interface.
Device Tests	Start and stop a lamp test.
Abort All Tests	To abort all current tests. Network-initiated tests will not be affected. An aborted test may continue to run for a few seconds as the abort command is sent to the remote end and processed.

Running Network Tests

To access the Network Tests screen, follow this menu selection sequence:

Main Menu → Test → Network Tests

```

main/test/network                                     Hotwire
Slot: 4                                              Model: 8775
Port: 4

                                NETWORK TESTS

Test                               Command  Status   Results
-----
Local Loopbacks
  Line Loopback:                   Start   Inactive  00:00:00
  Repeater Loopback:              Start   Inactive  00:00:00

Remote Loopbacks
  Send Line Loopback: Down      Send    Inactive  00:00:00

Pattern Tests
  Send and Monitor 511             Stop    Active    hh:mm:ss - Errors 99999+

-----
Ctrl-a to access these functions, ESC for previous menu   MainMenu  Exit
ResetMon

```

Use the **Command** column to start or stop a test. When the **Status** column shows that a test is Inactive, Start is displayed; when a test is Active, Stop is displayed. Position the cursor at the desired Start or Stop command and press Enter.

Selecting a Stop command on the Network Tests screen or Abort All Tests from the Test menu will not disrupt a network-initiated loopback.

The **Results** column displays the test duration.

When the Send and Monitor 511 test is active, ResetMon is available to reset the error counter to zero.

Line Loopback

Line Loopback (LLB) loops the received signal on the network interface back to the network without change.

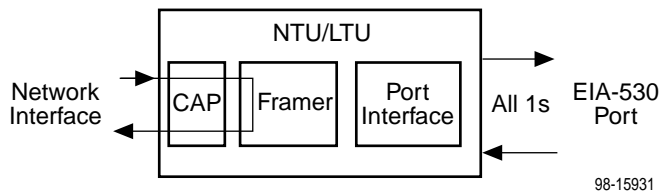

► Procedure

To run a Line Loopback:

1. Position the cursor at the Start command next to Line Loopback on the Network Tests screen.
2. Press Enter.
The Start command is changed to Stop.
3. To manually stop the test, verify that the cursor is positioned at the Stop command.
4. Press Enter.

Line Loopback cannot be started when a Repeater Loopback, Data Channel Loopback (DCLB), Remote DCLB, or network-initiated Line Loopback is in progress.

Repeater Loopback

Repeater Loopback (RLB) loops the signal being sent from the data port back to the data port and to the network interface.

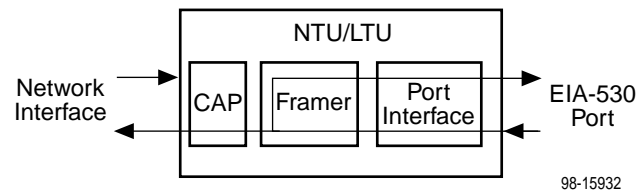

► Procedure

To run a Repeater Loopback:

1. Position the cursor at the Start command next to Repeater Loopback on the Network Tests screen.
2. Press Enter.
The Start command is changed to Stop.
3. To manually stop the test, verify that the cursor is positioned at the Stop command.
4. Press Enter.

Repeater Loopback cannot be started when a Line Loopback, DCLB, Remote DCLB, or Data Terminal Loopback (DTLB) is active.

NOTE:

If a disconnected DSL loop is connected while a Repeater Loopback is active, the connected units will not be able to synchronize.

Remote Send Line Loopback

Remote Send Line Loopback sends a line loopback Up or Down command to the remote unit for 10 seconds. When the remote unit detects the loopback Up command, it puts itself in line loopback and remains in loopback until it receives a loopback Down command.

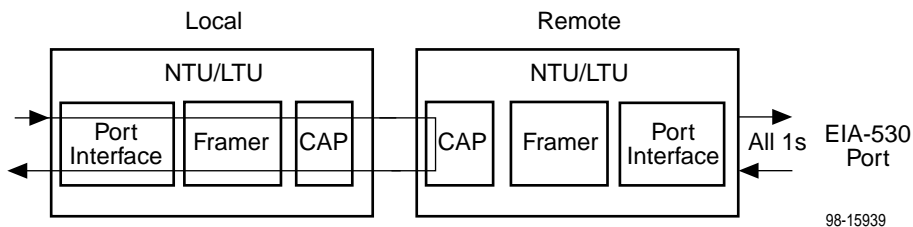

► Procedure

To run a Remote Send Line loopback:

1. Position the cursor at the Up or Down selection next to Send Line Loopback on the Network Tests screen.
2. Press the spacebar to select either Up or Down.
3. Position the cursor at the Send command next to Up or Down selection.
4. Press Enter.

The loopback stops automatically after 10 seconds. You cannot stop the test manually.

The Remote Send Line Loopback cannot be started when any other loopback or a Send and Monitor 511 test is active on the network interface.

Send and Monitor 511

The Send and Monitor 511 sends a test pattern over the network interface.

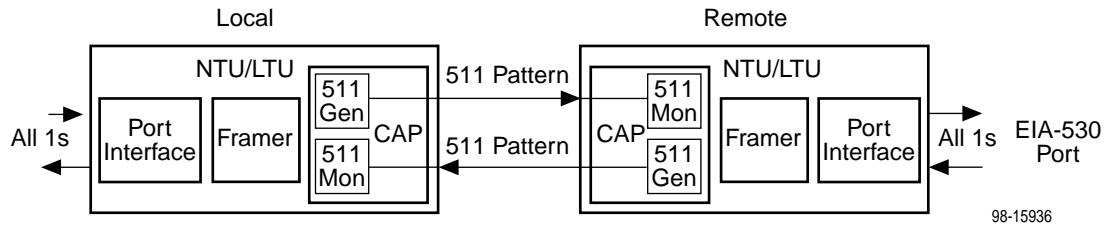

► Procedure

To run a Send and Monitor 511 test:

1. Position the cursor at the Start command next to Send and Monitor 511 on the Network Tests screen.
2. Press Enter.
The Start command is changed to Stop.
3. To manually stop the test, verify that the cursor is positioned at the Stop command.
4. Press Enter.

When a Send and Monitor 511 test is active, a count of bit errors is displayed next to the test duration, and the ResetMon virtual function key is available for use. Type r or R or select the ResetMon virtual function key to reset the error count.

Running SYNC Data Port Tests

To access the SYNC Data Port Tests screen, follow this menu selection sequence:

Main Menu → Test → SYNC Data Port Tests

```

main/test/data
Slot: 4
Port: 4
Hotwire
Model: 8775

          SYNC DATA PORT TESTS

Test                Command    Status    Results
-----
Local Loopbacks
  Data Terminal Loopback:  Start    Inactive  00:00:00
  Data Channel Loopback:   Start    Inactive  00:00:00

Remote Loopbacks
  Send Remote DCLB: Down    Send     Inactive  00:00:00

-----
Ctrl-a to access these functions, ESC for previous menu      MainMenu  Exit

```

Use the **Command** column to start or stop a test. When the **Status** column shows that a test is Inactive, Start is displayed; when a test is Active, Stop is displayed. Position the cursor at the desired Start or Stop command and press Enter.

The **Results** column displays the test duration.

Data Terminal Loopback

Data Terminal Loopback (DTLB) loops the user data back to the DTE. This loopback is located as closely as possible to the user data port (DTE) interface.

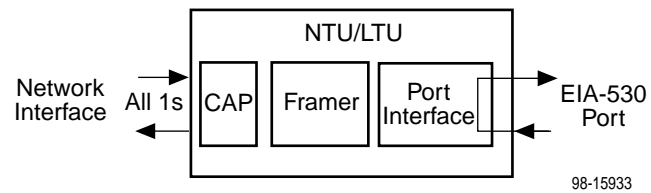

► Procedure

To run a Data Terminal Loopback:

1. Position the cursor at the Start command next to Data Terminal Loopback on the SYNC Data Port Tests screen.
2. Press Enter.
The Start command is changed to Stop.
3. To manually stop the test, verify that the cursor is positioned at the Stop command.
4. Press Enter.

Data Terminal Loopback cannot be started when a Repeater Loopback, DCLB, or Remote DCLB is already active on the data port.

Data Channel Loopback

Data Channel Loopback (DCLB) loops the data from the network interface back to the network. This loopback is located as closely as possible to the user data port (DTE) interface.

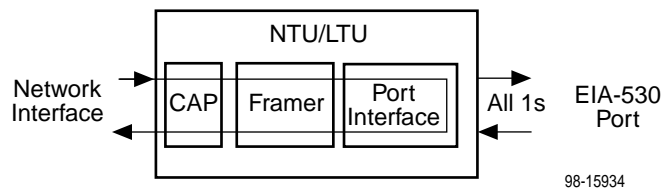

► Procedure

To run a Data Channel Loopback:

1. Position the cursor at the Start command next to Data Channel Loopback on the SYNC Data Port Tests screen.
2. Press Enter.
The Start command is changed to Stop.
3. To manually stop the test, verify that the cursor is positioned at the Stop command.
4. Press Enter.

Data Channel Loopback cannot be started when any of the following tests is active: Send and Monitor 511, Line Loopback, or Repeater Loopback on the network interface, or a Data Terminal Loopback on the data port.

Send Remote Data Channel Loopback

Send Remote Data Channel Loopback sends a line loopback up or down command to the remote unit for 10 seconds. When the remote unit detects the loopback up command, it puts itself in line loopback and remains in loopback until it receives a loopback down command.

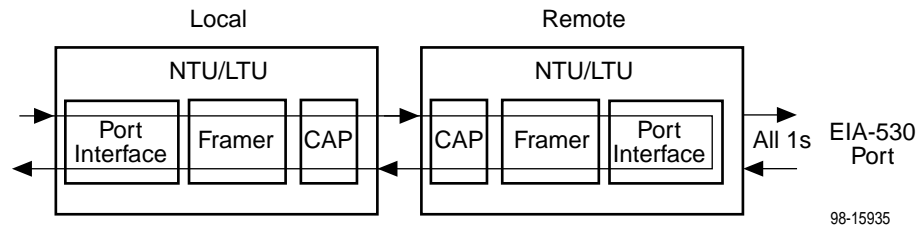

► Procedure

To send a Remote DCLB:

1. Position the cursor at the Up or Down selection next to Send Remote DCLB on the SYNC Data Port Tests screen.
2. Press the spacebar to select the desired code (Up or Down).
3. Position the cursor at the Start command next to Send Remote DCLB on the SYNC Data Port Tests screen.
4. Press Enter.

The Status field is changed to Sending. The Up or Down sequence transmission stops automatically after 10 seconds. You cannot stop the sequence manually.

The Send Remote DCLB test cannot be started when a Send and Monitor 511 test is active on the network interface.

Device Tests

The Device Tests branch is used to access the only card-level test, the Lamp Test. To access the Card Tests screen, follow this menu selection sequence:

Main Menu → Test → DeviceTests

```

main/test/card                               Hotwire
Slot: 4                                       Model: 8775

                                DEVIce TESTS

                                Test      Command  Status
-----
                                Lamp Test: Start  Inactive

-----
Ctrl-a to access these functions, ESC for previous menu      MainMenu  Exit

```

Lamp Test

The Lamp Test determines whether all LEDs are lighting and functioning properly.

► Procedure

To test the LEDs:

1. Position the cursor at the Start command next to Lamp Test on the Device Tests screen.
2. Press Enter.
The Start command is changed to Stop. During the Lamp Test, all LEDs blink simultaneously every second. When you stop the Lamp Test, the LEDs are restored to their normal condition.
3. To stop the Lamp Test, position the cursor at the Stop command.
4. Press Enter.

Ending an Active Test

Except for the Remote Send Line Loopback and Remote DCLB, a test initiated by the user can be ended by the user. Tests can also be terminated automatically by enabling the Test Timeout option from the System Options Menu.

- A Test Timeout option is available to automatically terminate a user-initiated Loopback or Pattern test (as opposed to manually terminating a test) after it has been running a specified period of time. The default is 10 minutes. Refer to Table A-4, [System Options](#).

Test Timeout does not pertain to tests initiated by the network.

- On each test screen is a Command column. To manually stop the test, press Enter when the cursor is on the Stop command.
- Use the Abort All Tests selection from the Test menu to stop all tests running on all interfaces, with the exception of network-initiated loopbacks. **Command Complete** appears when all tests on all interfaces have been terminated.

An aborted test may continue to run for a few seconds as the abort command is sent to the remote end and processed.

Messages and Troubleshooting

6

Overview

There are many messages available to assess the status of the device and contribute to problem resolutions. Refer to the following sections:

- *Configuring SNMP Traps*
- *Device Messages*
- *Troubleshooting*

Configuring SNMP Traps

An SNMP trap can be automatically sent out through the EOC or the Management port to the SNMP manager when the unit detects conditions set by the user. These traps enable the SNMP manager to gauge the state of the network. Refer to Appendix B, *Standards Compliance for SNMP Traps*, for details of SNMP traps supported by the unit.

To configure the Hotwire 8775 Termination Unit for SNMP traps, use the SNMP Traps Options screen to:

- Enable SNMP traps.
- Set the number of SNMP managers that receive SNMP traps from the unit.
- Enter an IP address and network destination for each SNMP manager specified.
- Select the type of SNMP traps to be sent from the unit.

To configure SNMP Traps, follow this menu selection sequence:

*Main Menu → Configuration → Load Configuration From →
Management and Communication Options → SNMP Traps Options*

```

main/config/management/trap
Slot: 4
Hotwire
Model: 8775

SNMP TRAPS OPTIONS

SNMP Traps:      Enable      Number of Trap Managers: 5

NMS 1 IP Address: 135.014.040.001 Clear Destination: IMC
NMS 2 IP Address: 135.014.003.027 Clear Destination: IMC
NMS 3 IP Address: 135.014.001.008 Clear Destination: IMC
NMS 4 IP Address: 135.014.002.024 Clear Destination: IMC
NMS 5 IP Address: 204.128.146.035 Clear Destination: IMC

General Traps:      Both
Enterprise Specific Traps: Enable
Link Traps:         Both
Link Traps Interfaces: Network

-----
Ctrl-a to access these functions, ESC for previous menu      MainMenu Exit
Save
    
```

Refer to Table A-8, *SNMP Traps Options*.

Device Messages

The Device Messages in Table 6-1, listed in alphabetical order, may appear in the messages area at the bottom of the ATI screens.

Table 6-1. Device Messages (1 of 2)

Device Message	What Message Indicates	What To Do
Access level is Operator. Configuration is read-only.	The operator requested that configuration options be loaded, but does not have authority to edit them.	If configuration options are to be edited, use a Login ID that has Administrator authority.
Cannot Save – no Login IDs with Access Administrator	All of the login IDs being saved have an access level below Administrator.	Change the access level of at least one Login ID to Administrator so that configuration changes can be made. (Operator-level users cannot make configuration changes.) Save the Login IDs.
Command Complete	Action requested has successfully completed.	No action needed.
Invalid Character (x)	A nonprintable ASCII character (x) has been entered.	Reenter information using valid characters.
Invalid – Data Terminal Initiated Loopback Active	Network-initiated loopback was in progress when another selection was made.	No action needed.
Invalid Password	Login is required and an incorrect password was entered; access is denied.	<ul style="list-style-type: none"> ■ Try again. ■ Contact your system administrator to verify your password.
Invalid – Send Pattern Already Active	A pattern test was already in progress when the Start field was selected.	<ul style="list-style-type: none"> ■ Allow test to continue. ■ Select another test. ■ Stop the test.
Invalid – [Test] Already Active	The described test was already in progress when another selection was made.	<ul style="list-style-type: none"> ■ Allow test to continue. ■ Select another test. ■ Stop the test.
Invalid Test Combination	A loopback or pattern test was in progress when Start was selected to start another test, or was active on the same or another interface when Start was selected.	<ul style="list-style-type: none"> ■ Wait until other test ends and message clears. ■ Abort all tests from the Test menu screen. ■ Stop the test from the same screen the test was started from.

Table 6-1. Device Messages (2 of 2)

Device Message	What Message Indicates	What To Do
IP address not in MCC subnet <i>nnn.nnn.nnn.nnn</i>	The Peer IP address specified is not in the same subnet as the MCC.	Enter an IP address that is in the same subnet as the MCC.
Limit of six Login IDs reached	An attempt to enter a new login ID was made, and the limit of six login/password combinations has been reached.	<ol style="list-style-type: none"> 1. Delete another login/password combination. 2. Re-enter the new login ID.
No Security Records to Delete	Delete was selected from the Administer Login screen, and no security records had been defined.	<ul style="list-style-type: none"> ■ No action needed. ■ Enter a security record.
Password Matching Error – Re-enter Password	Password entered in the Re-enter Password field of the Administer Logins screen does not match what was entered in the Password field.	<ul style="list-style-type: none"> ■ Try again. ■ Contact your system administrator to verify your password.
Please Wait	Command takes longer than 5 seconds.	Wait until message clears.
Test Active	A test is running and no higher priority health and status messages exist.	<ul style="list-style-type: none"> ■ Contact service provider if test initiated by the network. ■ Wait until the other test ends and message clears. ■ Cancel all tests from the Test screen. ■ Stop the test from the same screen the test was started from.
0.0.0.0 is an invalid IP address	An IP address of all zeros was entered.	Enter a valid, non-zero IP address.

Troubleshooting

The Hotwire 8775 Termination Unit is designed to provide you with many years of trouble-free service. If a problem occurs, however, refer to Table 6-2 for possible solutions.

Table 6-2. Troubleshooting

Symptom	Possible Cause	Solutions
Alarm LED is on.	A system failure has occurred	Refer to Table 4-1, Health and Status Messages , for recommended action.
Cannot access the unit via the ATI.	The terminal is not set up for the correct rate or data format, or the unit is configured so it prevents access.	<ul style="list-style-type: none"> ■ Check the cable and connections. ■ Ensure that the unit is configured properly in the DSLAM. Verify its IP address. ■ Reset the unit.
Device Fail appears on the System and Test Status screen under Self-Test results.	The unit detects an internal hardware failure.	<ul style="list-style-type: none"> ■ Reset the unit. ■ Contact your service representative.
No power, or the LEDs are not lit.	The unit is not properly seated in the DSLAM.	Verify that the unit is properly inserted.
	There is no power to the DSLAM.	Verify that the DSLAM has power.
An LED is not lit.	LED is out.	Run the Lamp Test. If the LED in question does not flash with the other LEDs, then contact your service representative.
Not receiving data.	<ul style="list-style-type: none"> ■ The network or data port cables are not connected (check front panel LEDs for more information). ■ A test is being executed on the unit (check the TEST LED on the front panel). ■ The SYNC Data Port is not enabled. ■ The far-end device is offline. 	<ul style="list-style-type: none"> ■ Check network and data port cables. ■ Run Loopback tests. Refer to Chapter 5, Testing. ■ Stop the test or wait for the test to end. ■ Enable the SYNC Data Port. ■ Make sure the far-end device is on.
Power-On Self-Test fails. Only Alarm LED is on after power-on.	The unit has detected an internal hardware failure.	<ul style="list-style-type: none"> ■ Reset the unit and try again. ■ Contact your service representative.

Security

7

Overview

The Hotwire 8775 Termination Unit provides several methods of security by limiting user access to the ATI through option settings. You can:

- Enable the Telnet Login Required option.
- Limit the access by setting a Session Access Level option of Operator for the Telnet Session.
- Disable the access with the Telnet Session option.

See Table A-5, [Telnet Sessions Options](#), in Appendix A, *Configuration Option Tables*.

ATI Access Levels

The Hotwire 8775 Termination Unit has two access levels: Administrator and Operator. The access level determines what functions are accessible, as shown in Table 7-1.

Table 7-1. Access Levels

ATI Access to Menu Functions	Administrator	Operator
Status	Read-Only	Read-Only
Test	Full Access	No Access
Configuration	Full Access	Read-Only
Control	Full Access	No Access

The effective access level is the more restrictive of the session access level or the login access level.

Access level is also used to control access via Telnet. If the Telnet Session Access Level is set to Administrator (see Table A-5, [Telnet Sessions Options](#)), a Login ID with an Operator access level is not permitted access.

Creating a Login

Logins apply to Telnet access directly to the ATI of the unit. The Administer Logins menu option is not presented when you access the unit through the MCC.

Six login ID/password combinations are available. Each Login ID and Password must be unique and include an access level.

► Procedure

1. To create a login record, follow this menu selection sequence:

Main Menu → Control → Administer Logins

```

main/control/admin_logins                               Hotwire
Slot: 4                                                Model: 8775

                                     ADMINISTER LOGINS                               Page 1 of 1

Login ID:                newuser
Access Level:            Administrator

                                     Are You Sure? Yes

-----
Save  PgUp  PgDn                ESC for previous menu                MainMenu  Exit
                                     New                        Delete

```

2. Select New and press Enter. The Login Entry screen is displayed.

```

main/control/admin_logins                               Hotwire
Slot: 4                                                Model: 8775

                                     LOGIN ENTRY

Login ID:                newuser
Password:                e34t136
Re-enter Password:      e34t136
Access Level:            Administrator

                                     WARNING
New logins will not become permanent until saved
through the "ADMINISTER LOGINS" screen!

-----
Ctrl-a to access these functions  ESC for previous menu                MainMenu  Exit
Save  PgUp  PgDn                New                        Delete

```

3. Create the login by entering the following fields. Login IDs and passwords are case-sensitive.

On the Login Entry screen, for the . . .	Enter . . .
Login ID	1 to 10 ASCII printable characters (hex21 through 7E). Blanks are not allowed.
Password	1 to 10 ASCII printable characters that can consist of 0–9, a–z, A–Z, # (pound), . (period), – (dash), and / (slash).
Re-enter Password	1 to 10 ASCII printable characters that can consist of 0–9, a–z, A–Z, # (pound), . (period), – (dash), and / (slash).
Access Level	Administrator, Operator

NOTE:

Assign at least one Administrator-level Login ID. Full access is necessary to make configuration option changes and administer logins.

4. Press Ctrl-a to switch to the screen function key area below the dotted line. Select Save and press Enter.
5. When Save is complete, **Command Complete** appears at the bottom of the screen.
6. If additional logins are required, repeat Steps 3 through 5
7. When all logins are entered, press Esc to return to the Administer Logins screen.
8. Select Save and press Enter.

Deleting a Login

► **Procedure**

1. To delete a login record, follow this menu selection sequence:
Main Menu → Control → Administer Logins
2. Select PgUp or PgDn and press Enter to page through login pages/records until you find the one to be deleted.
3. Once the correct record is displayed, select De~~l~~ete and press Enter.
4. To complete the delete action, select Save and press Enter.
When the deletion is complete, **Command Complete** appears at the bottom of the screen. The number of login pages/records reflects one less record, and the record following the deleted record appears.

Controlling SNMP Access

There are three methods for limiting SNMP access.

- Disable the SNMP management option. Refer to Table A-6, [General SNMP Management Options](#).
- Assign SNMP community names and access types.
- Limit SNMP access through validation of the IP address of each allowed SNMP manager.

Assigning SNMP Community Names and Access Types

The unit can be managed by an SNMP manager supporting SNMP. The community name must be supplied by an external SNMP manager accessing an object in the MIB.

To define SNMP community names, follow this menu selection sequence:

Main Menu → Configuration → Load Configuration From → Edit → SNMP → General SNMP Management

Refer to Table A-6, [General SNMP Management Options](#), to:

- Enable SNMP Management.
- Assign the SNMP community names of the SNMP Managers that are allowed to access the units Management Information Base (MIB).
- Specify Read or Read/Write access for each SNMP community name.

Limiting SNMP Access through the IP Addresses of the Managers

The unit provides an additional level of security through validation of the IP addresses.

The SNMP Management option must be enabled. To control SNMP access with IP addresses, follow this menu selection sequence:

Main Menu → Configuration → Management → Security Menu

Refer to Table A-7, [SNMP NMS Security Options](#). The SNMP access can be limited by:

- Enabling NMS IP address checking.
- Add each IP address and access level.

NOTE:

Do not change or delete the IP address or access level of the NMS performing the sets or enable IP address checking prior to adding the NMS to the table.

IP Addressing

8

Selecting an IP Addressing Scheme

Your IP addressing scheme depends in part whether the MCC controlling the chassis is running IP Conservative software.

Configurations Not Running IP Conservative Software

In a configuration not running IP Conservative software, the NTU's network interface IP address is assigned through the peer IP address of the LTU's Network Interface menu.

The termination unit is assigned an IP address and subnet through the DSLAM *Configuration* → *DSL Cards* → *Set IP Address* menu. Once the address is assigned, you can use the ATI to assign:

- Peer IP addresses to the four M/SDSL ports. These addresses are used as the IP addresses of the remote units. See Table A-1, [Network Interface Options](#), in Appendix A, *Configuration Option Tables*.
- An IP address for each NMS to act as a trap manager. See Table A-8, [SNMP Traps Options](#), in Appendix A, *Configuration Option Tables*.

All Configurations

The NTU obtains its IP address when the PPP link is established over the EOC.

Use the ATI to assign:

- An IP address for each NMS. See Table A-7, [SNMP NMS Security Options](#), in Appendix A, *Configuration Option Tables*.
- An IP address for the TFTP server you wish to use to upload and download configurations. See [Configuration Loader](#) in Chapter 3, *Initial Startup and Configuration*, and the documentation for your TFTP server.

Review the following information in preparation for selecting an IP addressing scheme.

- Any legal host address is allowed for a given subnet. The address choice within the subnet is arbitrary.
- A single route to a subnet is all that is needed to reach every device on a subnet. The unit's routing table supports a maximum of 20 routes.

IP Addressing Example

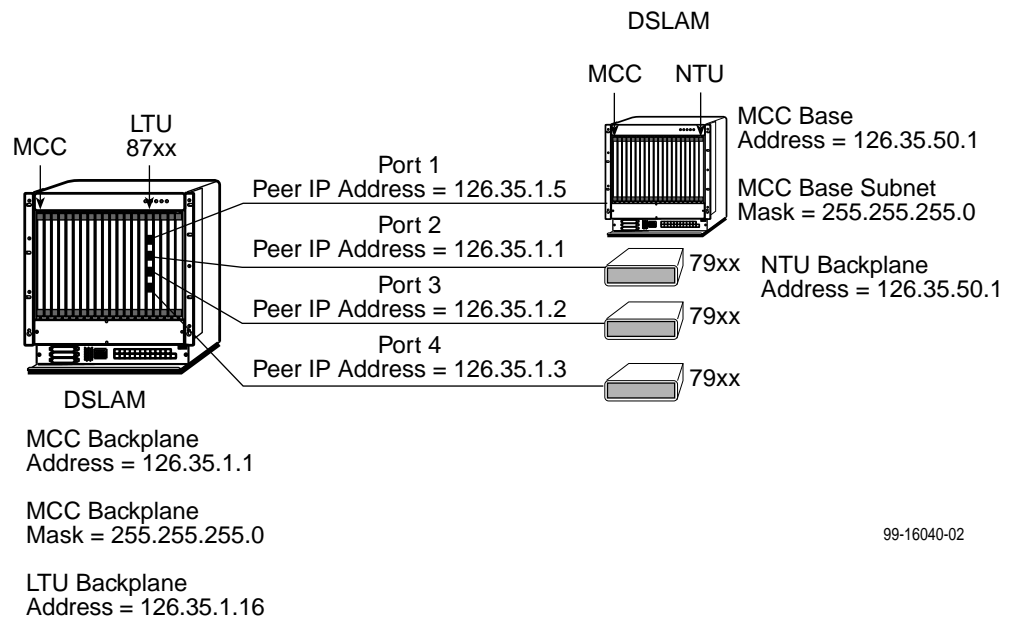

99-16040-02

Peer IP Address Assignments

- The Peer IP Address refers to the IP address of the unit configured as an NTU.
- The Peer IP Address is assigned by the LTU.

Configuration Option Tables



Overview

The tables in this appendix summarize the configuration options accessed when you select Configuration on the Main Menu. The configuration options are arranged into groups based upon functionality.

Select . . .	To Access the . . .	To Configure the . . .
Network	Network Interface Options , Table A-1	DSL network interface Ports 1–4.
SYNC Ports	Synchronous Data Port Options , Table A-2	Synchronous DTE interface Ports 1–4.
Copy Ports	Copy Ports Options , Table A-3	DSL network and synchronous DTE interface ports by copying options from port to port.
System	System Options , Table A-4	General system options of the unit.
Management and Communication	<ul style="list-style-type: none">■ Telnet Sessions Options, Table A-5■ General SNMP Management Options, Table A-6■ SNMP NMS Security Options, Table A-7■ SNMP Traps Options, Table A-8	Management support of the unit through SNMP and Telnet.

NOTE:

All changes to configuration options must be saved. Refer to [Saving Configuration Options](#) in Chapter 3, *Initial Startup and Configuration*.

Network Interface Options Menu

For Network Interface Options, refer to Table A-1. To access the Network Interface Options screen, follow this menu selection sequence:

Main Menu → Configuration → Load Configuration From → Network

Table A-1. Network Interface Options (1 of 2)

Margin Threshold
Possible Settings: -5db, -4db, -3db, -2db, -1db, 0db, 1db, 2db, 3db, 4db, 5db, 6db, 7db, 8db, 9db, 10db Default Setting: 3db
Determines the level, expressed in decibels, at which a signal-to-noise margin condition is recognized. -5db to 10db – Sets the margin threshold to this value.
Excessive Error Rate Threshold
Possible Settings: 1E-4, 1E-5, 1E-6, 1E-7, 1E-8, 1E-9 Default Setting: 1E-6
Determines the error rate at which an excessive error rate (EER) condition is recognized. The rate is the ratio of the number of CRC errors to the number of bits received in a certain period.
AutoRate
Possible Settings: Enable, Disable Default Setting: Enable
Determines whether the unit automatically adjusts to the best line rate for conditions, or is fixed at the rate in the DSL Line Rate field. The automatically set rate cannot exceed DSL Line Rate. Enable – The LTU is set to adjust at the best line rate. Disable – The LTU Line rate is user selectable and is based on the DSL Line Rate selected.

Table A-1. Network Interface Options (2 of 2)

DSL Line Rate
Possible Settings: 144, 272, 400, 528, 784, 1040, 1552, 2064 Default Setting: 144
Determines the fixed line rate of the LTU when AutoRate is disabled, and the maximum rate to which the unit can be set when AutoRate is enabled. <ul style="list-style-type: none"> ■ DSL Line Rate is only available when the unit is configured as an LTU. <p>144 – Available payload rates are: 64 and 128 kbps.</p> <p>272 – Available payload rates are: 192 and 256 kbps.</p> <p>400 – Available payload rates are: 320 and 384 kbps.</p> <p>528 – Available payload rates are: 448 and 512 kbps.</p> <p>784 – Available payload rates are: 576, 640, 704, and 768 kbps.</p> <p>1040 – Available payload rates are: 832, 896, 960, and 1024 kbps.</p> <p>NOTE: DSL Line Rates of 1552 and 2064 kbps are available only on the 2 Mbps termination unit.</p> <p>1552 – Available payload rates are: 1088, 1152, 1216, 1280, 1344, 1408, 1472, and 1536 kbps.</p> <p>2064 – Available payload rates are: 1600, 1664, 1728, 1792, 1856, 1920, 1984, and 2048 kbps.</p>
Peer IP Address
Possible Settings: 001.000.000.000 – 223.255.255.255, Clear Default Setting: 000.000.000.000
Specifies the peer IP address providing the remote management link on the DSL loop. <ul style="list-style-type: none"> ■ Peer IP Address is only available when the unit is configured as an LTU and the unit is not running in IP Conservative mode. <p>001.000.000.000 – 223.255.255.255 – Enter an address for the peer unit. The range for the first byte is 001 to 223, with the exception of 127. The range for the remaining three bytes is 000 to 255. The peer IP address must be in the same subnet as the MCC address.</p> <p>Clear – Clears the IP address and sets to all zeros.</p>
Circuit Identifier
Possible Settings: [ASCII Text], Clear Default Setting: [blank]
Uniquely identifies the circuit number of the transmission vendor's DSL line for troubleshooting purposes. <p>[ASCII Text] – Enter a maximum of 128 characters. All printable ASCII characters except ^ (caret) are allowed.</p> <p>Clear – Clears the field.</p>

Synchronous Data Port Options Menu

For Synchronous Data Port Options, refer to Table A-2. To access the Synchronous Data Port Options screen, follow this menu selection sequence:

Main Menu → Configuration → Load Configuration From → SYNC Ports

Table A-2. Synchronous Data Port Options (1 of 3)

Port Type
Possible Settings: E530A, V.35, RS449, X.21 Default Setting: E530A
Determines the port type for the data port. E530A – The port is configured as an EIA-530-A compatible DCE. An EIA-530-A compatible DTE can be connected directly to the DB25 Port connector on the rear panel of the unit. V.35 – The port is configured as a V.35 compatible DCE. A V.35 compatible DTE can be connected using an MS34 to DB25 adaptor cable to connect to the DB25 Port connector on the rear panel of the unit. E530A – The port is configured as an RS449 compatible DCE. An RS449 compatible DTE can be connected using a DB37 to DB25 adaptor cable to connect to the DB25 Port connector on the rear panel of the unit. X.21 – The port is configured as an X.21 compatible DCE. An X.21 compatible DTE can be connected using a DB15 to DB25 adaptor cable to connect to the DB25 Port connector on the rear panel of the unit.
Port Status
Possible Settings: Enable, Disable Default Setting: Enable
Determines whether the port can be configured and used. Enable – The port can be configured and used. Disable – The port cannot be configured or used. Configuration fields for the port are inaccessible, no alarms or traps associated with the port are generated, and the LED associated with the port is set to OFF.
Payload Rate
Possible Settings: 64, 128, 192, 256, 320, 384, 448, 512, 576, 640, 704, 768, 832, 896, 960, 1024, 1088, 1152, 1216, 1280, 1344, 1408, 1472, 1536, 1600, 1664, 1728, 1792, 1856, 1920, 1984, 2048 Default Setting: 128
Specifies the payload rate of the port. <ul style="list-style-type: none"> ■ Payload Rate is available only if AutoRate is disabled. <p>NOTE: Payload rates of 1088 kbps and higher are available only with the 2 Mbps termination unit.</p> <p>64 to 2048 – Sets the payload rate in.</p>

Table A-2. Synchronous Data Port Options (2 of 3)

Transmit Clock Source
Possible Settings: Internal, External Default Setting: Internal
<p>Specifies whether the transmitted data for the synchronous data port is clocked using an internal clock provided by the Hotwire 8775 Termination Unit (synchronized to the clock source specified by the clock source configuration option) or an external clock provided by the DTE connected to the synchronous data port. If an external clock is used, it must be synchronized to the same clock source as the Hotwire 8775 Termination Unit.</p> <p>Internal – Indicates the clock is provided internally by the Hotwire 8775 Termination Unit on the TXC interchange circuit DB (ITU-T 114).</p> <p>External – Indicates the clock is provided externally by the DTE on the XTXC interchange circuit DA (ITU-T 113). Use this selection if the clock source is set to the data port.</p>
Invert Transmit Clock
Possible Settings: Disable, Enable Default Setting: Disable
<p>Specifies whether the clock supplied by the Hotwire 8775 Termination Unit on the TXC interchange circuit DB (ITU-T 114) is phase inverted with respect to the Transmitted Data interchange circuit BA (ITU-T 103). This configuration option is useful when long cable lengths between the Hotwire 8775 Termination Unit and the DTE are causing data errors.</p> <p>Disable – Indicates TXC supplied by the Hotwire 8775 Termination Unit on this port is not phase inverted.</p> <p>Enable – Indicates TXC supplied by the Hotwire 8775 Termination Unit on this port is phase inverted.</p>
Send All Ones on Data Port Not Ready
Possible Settings: Both, Disable, DTR, RTS Default Setting: Both
<p>Specifies the conditions on the data port that determine when valid data is not being sent from the DTE. When this condition is detected, all ones are sent to the network.</p> <p>Both – Monitors both DTR and RTS. If either is interrupted, all ones are sent to the network.</p> <p>Disable – Disables the monitoring of interchange circuits from the DTE connected to the synchronous data port.</p> <p>DTR – Monitors the DTE Ready interchange circuit CD (ITU-T 108/1/2). When DTR is interrupted, all ones are sent to the network.</p> <p>RTS – Monitors the Request-to-Send interchange circuit CA (ITU-T 105). When RTS is interrupted, all ones are sent to the network.</p>

Table A-2. Synchronous Data Port Options (3 of 3)

Action on Network LOS Alarm
Possible Settings: Halt, None Default Setting: Halt
Specifies the action taken on the synchronous data port when an LOS (Loss Of Signal) alarm is received on the network interface. Halt – Stops the transmission of data on the data port and disables the data port when LOS alarms are received on the network interface. When LOS alarms are received, all ones are sent on the Received Data interchange circuit BB (ITU-T 104). The Clear-to-Send interchange circuit CB (ITU-T 106) is interrupted. None – Makes the data port unaffected by LOS alarms received on the network interface.
Network Initiated Data Channel Loopback
Possible Settings: Disable, Enable Default Setting: Disable
Allows the initiation and termination of a Data Channel Loopback (DCLB) by the receipt of a DCLB-actuate sequence or DCLB-release sequence from the network or far-end device. Disable – Ignores the DCLB-actuate and DCLB-release sequences for this port. Enable – DCLB-actuate and DCLB-release sequences are recognized for this port.
Port (DTE) Initiated Loopbacks
Possible Settings: Disable, DTLB, DCLB, Both Default Setting: Disable
Allows the initiation and termination of a local Data Terminal Loopback (DTLB) or remote Data Channel Loopback (DCLB) by the DTE connected to this port. (DTLB is equivalent to a V.54 loop 3, and DCLB is equivalent to a V.54 loop 2.) Control of these loopbacks is through the DTE interchange circuits as specified by the V.54 standard. Disable – Disables control of local DTLBs and remote DCLBs by the DTE connected to this port. DTLB – Gives control of the local DTLBs for this port to the DTE attached to this port. This loopback is controlled by the Local Loopback interchange circuit LL (ITU-T 141). DCLB – Gives control of the remote DCLBs for the far-end port connected to this port to the DTE attached to this port. This loopback is controlled by the Remote Loopback interchange circuit RL (ITU-T 140). The far-end equipment must support in-band V.54 loopbacks. Both – Gives control of local DTLBs and remote DCLBs to the DTE connected to this port.
ElasticStore
Possible Settings: Disable, Enable Default Setting: Enable
Used to enable or disable the first-in, first-out (FIFO) buffer circuit for the incoming external clock. This circuit is used to compensate for the differences between the frequencies of the data clocks for the two units in the circuit. This option only applies if the unit is set for external timing. Do not enable Elastic Store if the attached DCE has an elastic store buffer larger than 32 bits. Disable – Disables the Elastic Store FIFO. Enable – Enables the Elastic Store FIFO.

Copy Ports Menu

You can copy the configuration options of one synchronous data port and DSL loop to another using the Copy Ports screen. For Copy Ports options, refer to Table A-3. To access the Copy Ports screen, follow this menu selection sequence:

Main Menu → Configuration → Load Configuration From → Copy Ports

Table A-3. Copy Ports Options

From: Port
Possible Settings: 1, 2, 3, 4 Default Setting: 1
Controls the source of the configuration options. 1 to 4 – The configuration of the selected port is copied.
To: Port
Possible Settings: 1, 2, 3, 4, All Default Setting: 2
Controls the target of the configuration options. 1 to 4 – The configuration of the selected port is replaced. If Perform Copy Then Increment is selected, the port number is incremented by 1 after the copy. All – The configurations of all ports are replaced by the configuration of the selected From: Port. NOTE: Peer IP Address and Circuit Identifier are <i>not</i> copied.

System Options Menu

For System Options, refer to Table A-4. To access the System Options screen, follow this menu selection sequence:

Main Menu → Configuration → Load Configuration From → System

Table A-4. System Options

DSL Mode
Possible Settings: LTU, NTU Default Setting: LTU
Controls whether the unit is configured as a control unit or tributary unit. LTU – The unit is configured as a control unit (Line Termination Unit). NTU – The unit is configured as a tributary unit (Network Termination Unit). This unit will request its IP address from the LTU during establishment of the PPP link. NOTE: Changing this option will reset the card.
Test Timeout
Possible Settings: Enable, Disable Default Setting: Enable
Allows user-initiated tests to end automatically. The feature should be enabled when the unit is remotely managed, so that control can be regained after a test is accidentally executed. Enable – User-initiated loopback and pattern tests end when test duration is reached. Disable – Tests must be terminated manually from the Network Tests screen. Refer to <i>Running Network Tests</i> in Chapter 5, <i>Testing</i> . NOTE: Tests commanded by the DTE or network-initiated tests are not affected by this test timeout.
Test Duration (min)
Possible Settings: 1–120 Default Setting: 10
Number of minutes for a test to be active before automatically ending. <ul style="list-style-type: none"> ■ Test Duration (min) option appears when Test Timeout is enabled. 1 to 120 – Amount of time in minutes for a user-initiated test to run before terminating.

Management and Communication Options Menu

The Management and Communication Menu includes the following:

- [Telnet Sessions Options](#), Table A-5
- [General SNMP Management Options](#), Table A-6
- [SNMP NMS Security Options](#), Table A-7
- [SNMP Traps Options](#), Table A-8

Telnet Sessions Options

To access the Telnet Session Options screen, follow this menu selection sequence:

*Main Menu → Configuration → Load Configuration From →
Management and Communication → Telnet Session*

Table A-5. Telnet Sessions Options

Telnet Session
Possible Settings: Enable, Disable Default Setting: Enable
Specifies if the unit will respond to a Telnet session request from a Telnet client on an interconnected IP network. Enable – Allows Telnet sessions between the unit and a Telnet client. Disable – No Telnet sessions allowed.
Telnet Login Required
Possible Settings: Enable, Disable Default Setting: Disable
Used to secure access to the ATI through a Telnet session. Login IDs are created with a password and access level. Refer to <i>Creating a Login</i> in Chapter 7, <i>Security</i> . Enable – Security is enabled. When access is attempted via Telnet, the user is prompted for a Login ID and password. Disable – No Login required for a Telnet session.
Session Access Level
Possible Settings: Administrator, Operator Default Setting: Administrator
The Telnet session access level is interrelated with the access level of the Login ID. Refer to <i>ATI Access Levels</i> in Chapter 7, <i>Security</i> , for more information. Administrator – This is the higher access level, permitting full control of the unit. Access level is determined by the Login ID. If Telnet Login Required is disabled, the session access level is Administrator. Operator – This is the lower access level, permitting read-only access to status and configuration screens.
Inactivity Timeout
Possible Settings: Enable, Disable Default Setting: Disable
Provides automatic logoff of a Telnet session. Enable – The Telnet session terminates automatically after the Disconnect Time. Disable – A Telnet session will not be closed due to inactivity.
Disconnect Time (Minutes)
Possible Settings: 1–60 Default Setting: 5
Number of minutes of inactivity before a Telnet session terminates automatically. Timeout is based on no keyboard activity. <ul style="list-style-type: none"> ▪ Disconnect Time (minutes) option appears when Inactivity Timeout is enabled. 1 to 60 – The Telnet session is closed after the selected number of minutes.

General SNMP Management Options

To access the General SNMP Management Options screen, follow this menu selection sequence:

Main Menu → Configuration → Load Configuration From → Edit → Management and Communication → SNMP → General SNMP Management

Table A-6. General SNMP Management Options

SNMP Management
Possible Settings: Enable, Disable Default Setting: Disable
Enables or disables the SNMP management features. Enable – Enables SNMP management capabilities. Disable – Disables SNMP management capabilities.
Community Name 1
Possible Settings: ASCII text field Default Text: Public
Identifies the name of the community allowed to access the unit's MIB. The community name must be supplied by an external SNMP manager when that manager attempts to access an object in the MIB. Text Field – Enter or edit a community name. Clear – Clears the community name field.
Name 1 Access
Possible Settings: Read, Read/Write Default Setting: Read
Determines the access level for Community Name 1. Read – Allows read-only access (get) for Community Name 1. Read/Write – Allows read/write access (get) for Community Name 1.
Community Name 2
Possible Settings: ASCII text field Default Text: [null string]
Identifies the name of the second community allowed to access the unit's MIB. The community name must be supplied by an external SNMP manager when that manager attempts to access an object in the MIB. Text Field – Enter or edit a community name. Clear – Clears the community name field.
Name 2 Access
Possible Settings: Read, Read/Write Default Setting: Read
Determines the access level for Community Name 2. Read – Allows read-only access (get) for Community Name 2. Read/Write – Allows read/write access (get/set) for Community Name 2.

SNMP NMS Security Options

To access the SNMP NMS Security Options screen, follow this menu selection sequence:

Main Menu → Configuration → Load Configuration From → Edit → Management and Communication → SNMP → Security

The SNMP NMS Security configuration options screen is not available in IP Conservative mode.

Table A-7. SNMP NMS Security Options

NMS IP Validation
Possible Settings: Enable, Disable Default Setting: Disable
Specifies whether security checking is performed on the IP address of SNMP management systems attempting to access the node. Enable – Security checking is performed on the IP address of SNMP management systems attempting to access the node. Disable – No security checking is performed.
Number of Managers
Possible Settings: 1, 2, 3, 4, 5, 6, 7, 8, 9, 10 Default Setting: 1
Specifies the number of SNMP management systems that can send SNMP messages. 1 to 10 – Number of trap managers. An NMS IP address is required for each manager.
NMS <i>n</i> IP Address
Possible Settings: 001.000.000.000 – 223.255.255.255, Clear Default Setting: 000.000.000.000
Specifies the Internet Protocol address used to identify each SNMP manager. 001.000.000.000 – 223.255.255.255 – Enter an address for each SNMP manager. The range for the first byte is 001 to 223, with the exception of 127. The range for the remaining three bytes is 000 to 255. Clear – Clears the IP address and sets to all zeros.
Access Level
Possible Settings: Read, Read/Write Default Setting: Read
Determines the access level allowed for an authorized NMS when IP address validation is being performed. Read – Allows read-only access (get) to the accessible objects in the MIB for this device. Read/Write – Allows read/write access (get/set) to the accessible objects in the MIB for this device.

SNMP Traps Options

To access the SNMP Traps Options screen, follow this menu selection sequence:

Main Menu → Configuration → Load Configuration From → Edit → Management and Communication → SNMP Traps

Table A-8. SNMP Traps Options (1 of 2)

SNMP Traps
Possible Settings: Enable, Disable Default Setting: Disable
Controls the generation of SNMP trap messages. Enable – SNMP trap messages are sent out to SNMP managers. Disable – No SNMP trap messages are sent out.
Number of Trap Managers
Possible Settings: 1, 2, 3, 4, 5 Default Setting: 1
Sets the number of SNMP management systems that will receive SNMP traps. <ul style="list-style-type: none"> ■ This field is available only when the unit is not running in IP Conservative mode. 1 to 5 – Number of trap managers. An NMS IP address is required for each manager.
NMS <i>n</i> IP Address
Possible Settings: 001.000.000.000 – 223.255.255.255, Clear Default Setting: 000.000.000.000
Specifies the Internet Protocol address used to identify each SNMP trap manager. <ul style="list-style-type: none"> ■ This field is available only when the unit is not running in IP Conservative mode. 001.000.000.000 – 223.255.255.255 – Enter an address for each SNMP trap manager. The range for the first byte is 001 to 223, with the exception of 127. The range for the remaining three bytes is 000 to 255. Clear – Clears the IP address and sets to all zeros.
NMS <i>n</i> Destination
Possible Settings: IMC, DSL1, DSL2, DSL3, DSL4 Default Setting: IMC
Provides the network destination path of each trap manager. <ul style="list-style-type: none"> ■ NMS <i>n</i> Destination is available only when the unit is configured as an NTU and not running in IP Conservative mode. Disabled ports cannot be specified. IMC – The In-band Management Channel (EOC) is the default network destination. DSL1 to DSL4 – The specified port is the network destination.

Table A-8. SNMP Traps Options (2 of 2)

General Traps
Possible Settings: Disable, Warm, AuthFail, Both Default Setting: Both
Determines which SNMP traps are sent to each trap manager. Disable – No general trap messages are sent. Warm – Sends trap message for <i>warmStart</i> events. AuthFail – Sends trap message for <i>authenticationFailure</i> events. Both – Sends both trap messages. NOTE: Refer to Appendix B, <i>Standards Compliance for SNMP Traps</i> .
Enterprise Specific Traps
Possible Settings: Enable, Disable Default Setting: Disable
Determines if SNMP traps are generated for enterprise-specific events. Enable – SNMP traps are generated for <i>enterpriseSpecific</i> events. NOTE: Refer to <i>Enterprise Specific Traps</i> in Appendix B, <i>Standards Compliance for SNMP Traps</i> . Disable – No enterprise-specific event traps are sent.
Link Traps
Possible Settings: Disable, Up, Down, Both Default Setting: Both
Determines if SNMP traps are generated for link up and link down for one of the communication interfaces. Disable – No <i>linkUp</i> or <i>linkDown</i> SNMP traps are generated. Up – A <i>linkUp</i> trap is generated when the unit recognizes that one of the communication interfaces is operational. Down – A <i>linkDown</i> trap is generated when the unit recognizes a failure in one of the communication interfaces. Both – Sends trap messages for detection of both <i>linkUp</i> and <i>linkDown</i> . NOTE: Refer to <i>linkUp and linkDown</i> in Appendix B, <i>Standards Compliance for SNMP Traps</i> .
Link Traps Interfaces
Possible Settings: Network, SYNC, All Default Setting: All
Determines if the SNMP <i>linkUp</i> , SNMP <i>linkDown</i> , and interface-related <i>enterpriseSpecific</i> traps are generated for the network interface and/or synchronous data (DTE) port. Network – SNMP trap messages are generated for the network interface. SYNC – SNMP trap messages are generated for the synchronous data (DTE) ports. All – SNMP trap messages are generated for the network interface and the synchronous data (DTE) ports.

Standards Compliance for SNMP Traps

B

SNMP Traps

This section describes the unit's compliance with SNMP standards and any special operational features for the SNMP traps supported. The unit supports the following traps:

- warmStart
- authenticationFailure
- linkUp
- linkDown

warmStart

SNMP Trap	Description	Possible Cause
warmStart	The unit has reinitialized itself. The trap is sent after the unit resets and stabilizes. There are no variable-bindings.	<ul style="list-style-type: none">■ Reset command.■ Power disruption.

authenticationFailure

SNMP Trap	Description	Possible Cause
authenticationFailure	Failed attempts to access the unit. There are no variable-bindings.	Three unsuccessful attempts were made to enter a correct login/password combination.

linkUp and linkDown

The link SNMP traps are:

- **linkUp** – The unit recognizes that one of the communication interfaces is operational.
- **linkDown** – The unit recognizes that one of the communication interfaces is not operational.

The network and synchronous port interfaces (physical sublayer) are represented by an entry in the MIB-II interfaces table and supported by the DS1 MIB.

The following list describes the conditions that define linkUp and linkDown:

linkUp/Down Variable-Bindings

- **ifIndex (RFC 1573)**
This object provides the index into the ifTable and potentially into tables in other MIBs. The values of ifIndex are the same for all models, although not all indexes are supported for each model.
The ifIndex included with the trap consists of the slot number times 1000, plus:
 - 2 DSL Interface, Port 1
 - 3 DSL Interface, Port 2
 - 4 DSL Interface, Port 3
 - 5 DSL Interface, Port 4
 - 10 Synchronous Data Port, Port 1
 - 11 Synchronous Data Port, Port 2
 - 12 Synchronous Data Port, Port 3
 - 13 Synchronous Data Port, Port 4
- **ifAdminStatus (RFC 1573)**
This object specifies the operational state of the interface:
 - up(1)
DSL Network: DSL link is established.
Synchronous Data Port: Port is enabled and both CTS and DSR are ON.
 - down(2)
DSL Network: DSL link is not established.
Synchronous Data Port: Port is disabled or CTS or DSR is OFF.
 - testing(3)
A test is active on the interface.
- **ifOperStatus (RFC 1573)**
This object contains the same value as ifAdminStatus.
- **ifType (RFC 1573)**
This object is the type of interface:
 - propPointToPointSerial(22)
Used for the synchronous data ports and EOC.
 - sdsI(96)
Used for the DSL network interface.

Enterprise-Specific Traps

The enterpriseSpecific trap indicates that an enterprise-specific event has occurred. The Specific-trap field identifies the particular trap that occurred. The following table lists the enterprise-specific traps supported by the unit:

SNMP Trap	Description	Possible Cause
enterpriseSelfTestFail(2)	A hardware failure of the unit is detected during the unit's self-test. The trap is generated after the unit completes initialization.	Failure of one or more of the unit's hardware components.
enterpriseDeviceFail(3)	An internal device failure.	Operating software has detected an internal device failure.
enterpriseTestStart(5)	A test is running.	At least one test has been started on an interface.
enterpriseConfigChange(6)	The configuration changed via the user interface. The trap is sent after 60 seconds have elapsed without another change. This suppresses the sending of numerous traps when multiple changes are made in a short period of time, as is typically the case when changing configuration options.	Configuration has been changed via the ATI.
enterpriseFallbackAutoRate(13)	The LTU, set to AutoRate enable, resynched at a lower rate when the line was restored after an LOS.	After a LOS condition the units trained up at a lower rate than the previous rate.
enterpriseFallbackAutoRateclear(113)	The fallback autorate condition has cleared and the units have resynched at the same rate.	The units automatically retrained at the same rate, were reset, or placed in fixed rate.
enterpriseTestStop(105)	All tests have been halted.	All tests have been halted on an interface.

There are no variable-bindings for enterpriseDeviceFail and enterpriseConfigChange. The variable-binding for enterpriseSelfTestFail is devSelfTestResults.

The tests that affect the enterpriseTestStart, enterpriseTestStop, and the variable-bindings are different for each particular interface. Diagnostic tests are only supported on the physical network and user data port interfaces. The specific tests and variable-bindings are described in the following table:

Interface	enterpriseTestStart/Stop Variable-Bindings	Possible Cause
DSL Network	<ul style="list-style-type: none"> ■ ifIndex (RFC 1573) ■ ifAdminStatus (RFC 1573) ■ ifOperStatus (RFC 1573) ■ ifType (RFC 1573) ■ ifTestType (RFC 1573) <p>The following objects control tests in SNMP-managed devices:</p> <ul style="list-style-type: none"> – noTest – Stops the test in progress. – testLoopLLB – Initiates a Local Loopback. – testLoopRLB – Initiates a Remote Loopback. – testSendMon511 – Initiates a Send and Monitor 511 test. – testSendLLBUp – Initiates an LLB Up message to the remote unit. – testSendLLBDown – Initiates an LLB Down message to the remote unit. 	<ul style="list-style-type: none"> ■ enterpriseTest Start – Any one of the following tests is active on the interface: <ul style="list-style-type: none"> – Line Loopback – Repeater Loopback – Remote Line Loopback – Send and Monitor 511 ■ enterpriseTest Stop – No tests currently running on the interface.
Synchronous Data Ports	<ul style="list-style-type: none"> ■ ifIndex (RFC 1573) ■ ifAdminStatus (RFC 1573) ■ ifOperStatus (RFC 1573) ■ ifTestType (RFC 1573) <p>The following objects control tests in SNMP-managed devices:</p> <ul style="list-style-type: none"> – noTest – Stops the test in progress. – testLoopDCLB – Initiates a Data Channel Loopback. – testLoopDTLB – Initiates a Data Terminal Loopback. – testSendDCLBUp – Initiates an DCLB Up message to the remote unit. – testSendDCLBDown – Initiates an DCLB Down message to the remote unit. 	<ul style="list-style-type: none"> ■ enterpriseTest Start – Any one of the following tests is active on the port: <ul style="list-style-type: none"> – Data Terminal Loopback – Data Channel Loopback – Remote Data Channel Loopback ■ enterpriseTest Stop – No tests currently running on the port.

Cables and Pin Assignments

C

Overview

The following sections provide pin assignments:

- *100-Pin Plug-to-Four DB25 Receptacle EIA-530-A Cable*
- *100-Pin Plug-to-Four MS34 Receptacle V.35 Cable*
- *100-Pin Plug-to-Four DB37 Receptacle RS-449 Cable*
- *100-Pin Plug-to-Four DB15 Receptacle X.21 Cable*

100-Pin Plug-to-Four DB25 Receptacle EIA-530-A Cable

Each row of the following table represents pins that are connected to each other.

Table C-1. EIA-530-A Cable Pinouts (1 of 3)

100-Pin Plug	Net Name	DB25 Socket	Pin Number	Net Name
8	PORT1_TD_H	Port 1	2	TD(A)
57	PORT1_TD_L	Port 1	14	TD(B)
10	PORT1_TXC_H	Port 1	15	TXC(A)
59	PORT1_TXC_L	Port 1	12	TXC(B)
12	PORT1_RD_H	Port 1	3	RD(A)
61	PORT1_RD_L	Port 1	16	RD(B)
11	PORT1_RXC_H	Port 1	17	RXC(A)
60	PORT1_RXC_L	Port 1	9	RXC(B)
9	PORT1_TT_H	Port 1	24	XTXC(A)
58	PORT1_TT_L	Port 1	11	XTXC(B)
52	PORT1_RTS_H	Port 1	4	RTS(A)
2	PORT1_RTS_L	Port 1	19	RTS(B)
55	PORT1_CTS_H	Port 1	5	CTS(A)
5	PORT1_CTS_L	Port 1	13	CTS(B)
4	PORT1_LSD_H	Port 1	8	CD(A)
53	PORT1_LSD_L	Port 1	10	CD(B)
54	PORT1_DSR	Port 1	6	DSR
3	PORT1_DTR	Port 1	20	DTR
6	PORT1_TM	Port 1	25	TM
N/C				N/C
51	PORT1_LL	Port 1	18	LL
56	GND	Port 1	7	GND
7	PORT1_RL	Port 1	21	RL
62	GND	Port 1	23	GND
		Port 1	22	RI
		Port 1	23	GND
20	PORT2_TD_H	Port 2	2	TD(A)
69	PORT2_TD_L	Port 2	14	TD(B)
22	PORT2_TXC_H	Port 2	15	TXC(A)
71	PORT2_TXC_L	Port 2	12	TXC(B)
24	PORT2_RD_H	Port 2	3	RD(A)
73	PORT2_RD_L	Port 2	16	RD(B)
23	PORT2_RXC_H	Port 2	17	RXC(A)
72	PORT2_RXC_L	Port 2	9	RXC(B)
21	PORT2_TT_H	Port 2	24	XTXC(A)
70	PORT2_TT_L	Port 2	11	XTXC(B)
64	PORT2_RTS_H	Port 2	4	RTS(A)

Table C-1. EIA-530-A Cable Pinouts (2 of 3)

100-Pin Plug	Net Name	DB25 Socket	Pin Number	Net Name
14	PORT2_RTS_L	Port 2	19	RTS(B)
67	PORT2_CTS_H	Port 2	5	CTS(A)
17	PORT2_CTS_L	Port 2	13	CTS(B)
16	PORT2_LSD_H	Port 2	8	CD(A)
65	PORT2_LSD_L	Port 2	10	CD(B)
66	PORT2_DSR	Port 2	6	DSR
15	PORT2_DTR	Port 2	20	DTR
18	PORT2_TM	Port 2	25	TM
N/C				N/C
63	PORT2_LL	Port 2	18	LL
68	GND	Port 2	7	GND
19	PORT2_RL	Port 2	21	RL
74	GND	Port 2	23	GND
		Port 2	22	RI
		Port 2	23	GND
32	PORT3_TD_H	Port 3	2	TD(A)
81	PORT3_TD_L	Port 3	14	TD(B)
34	PORT3_TXC_H	Port 3	15	TXC(A)
83	PORT3_TXC_L	Port 3	12	TXC(B)
36	PORT3_RD_H	Port 3	3	RD(A)
85	PORT3_RD_L	Port 3	16	RD(B)
35	PORT3_RXC_H	Port 3	17	RXC(A)
84	PORT3_RXC_L	Port 3	9	RXC(B)
33	PORT3_TT_H	Port 3	24	XTXC(A)
82	PORT3_TT_L	Port 3	11	XTXC(B)
76	PORT3_RTS_H	Port 3	4	RTS(A)
26	PORT3_RTS_L	Port 3	19	RTS(B)
79	PORT3_CTS_H	Port 3	5	CTS(A)
29	PORT3_CTS_L	Port 3	13	CTS(B)
28	PORT3_LSD_H	Port 3	8	CD(A)
77	PORT3_LSD_L	Port 3	10	CD(B)
78	PORT3_DSR	Port 3	6	DSR
27	PORT3_DTR	Port 3	20	DTR
30	PORT3_TM	Port 3	25	TM
N/C				N/C
75	PORT3_LL	Port 3	18	LL
80	GND	Port 3	7	GND
31	PORT3_RL	Port 3	21	RL
86	GND	Port 3	23	GND
		Port 3	22	RI
		Port 3	23	GND
44	PORT4_TD_H	Port 4	2	TD(A)
93	PORT4_TD_L	Port 4	14	TD(B)

Table C-1. EIA-530-A Cable Pinouts (3 of 3)

100-Pin Plug	Net Name	DB25 Socket	Pin Number	Net Name
46	PORT4_TXC_H	Port 4	15	TXC(A)
95	PORT4_TXC_L	Port 4	12	TXC(B)
48	PORT4_RD_H	Port 4	3	RD(A)
97	PORT4_RD_L	Port 4	16	RD(B)
47	PORT4_RXC_H	Port 4	17	RXC(A)
96	PORT4_RXC_L	Port 4	9	RXC(B)
45	PORT4_TT_H	Port 4	24	XTXC(A)
94	PORT4_TT_L	Port 4	11	XTXC(B)
88	PORT4_RTS_H	Port 4	4	RTS(A)
38	PORT4_RTS_L	Port 4	19	RTS(B)
91	PORT4_CTS_H	Port 4	5	CTS(A)
41	PORT4_CTS_L	Port 4	13	CTS(B)
40	PORT4_LSD_H	Port 4	8	CD(A)
89	PORT4_LSD_L	Port 4	10	CD(B)
90	PORT4_DSR	Port 4	6	DSR
39	PORT4_DTR	Port 4	20	DTR
42	PORT4_TM	Port 4	25	TM
N/C				N/C
87	PORT4_LL	Port 4	18	LL
92	GND	Port 4	7	GND
43	PORT4_RL	Port 4	21	RL
98	GND	Port 4	23	GND
		Port 4	22	RI
		Port 4	23	GND
49	CABLE_ID			
37	GND			
100-Pin plug	Shield	Port 1	1	SHIELD
		Port 2	1	SHIELD
		Port 3	1	SHIELD
		Port 4	1	SHIELD

100-Pin Plug-to-Four MS34 Receptacle V.35 Cable

Each row of the following table represents pins that are connected to each other.

Table C-2. V.35 Cable Pinouts (1 of 3)

100-Pin Plug	Net Name	MS34 Socket	Pin Number	Net Name
8	PORT1_TD_H	Port 1	P	TD(A)
57	PORT1_TD_L	Port 1	S	TD(B)
10	PORT1_TXC_H	Port 1	Y	TXC(A)
59	PORT1_TXC_L	Port 1	AA	TXC(B)
12	PORT1_RD_H	Port 1	R	RD(A)
61	PORT1_RD_L	Port 1	T	RD(B)
11	PORT1_RXC_H	Port 1	V	RXC(A)
60	PORT1_RXC_L	Port 1	X	RXC(B)
9	PORT1_TT_H	Port 1	U	XTXC(A)
58	PORT1_TT_L	Port 1	W	XTXC(B)
52	PORT1_RTS_H	Port 1	C	RTS
N/C				N/C
55	PORT1_CTS_H	Port 1	D	CTS
N/C				N/C
4	PORT1_LSD_H	Port 1	F	RLSD
N/C				N/C
3	PORT1_DTR	Port 1	H	DTR
54	PORT1_DSR	Port 1	E	DSR
6	PORT1_TM	Port 1	NN	TM
N/C				N/C
51	PORT1_LL	Port 1	L	LL
56	GND	Port 1	B	GND
7	PORT1_RL	Port 1	N	RL
62	GND	Port 1	B	GND
		Port 1	J	CI
		Port 1	B	GND
20	PORT2_TD_H	Port 2	P	TD(A)
69	PORT2_TD_L	Port 2	S	TD(B)
22	PORT2_TXC_H	Port 2	Y	TXC(A)
71	PORT2_TXC_L	Port 2	AA	TXC(B)
24	PORT2_RD_H	Port 2	R	RD(A)
73	PORT2_RD_L	Port 2	T	RD(B)
23	PORT2_RXC_H	Port 2	V	RXC(A)
72	PORT2_RXC_L	Port 2	X	RXC(B)
21	PORT2_TT_H	Port 2	U	XTXC(A)
70	PORT2_TT_L	Port 2	W	XTXC(B)
64	PORT2_RTS_H	Port 2	C	RTS
N/C				N/C

Table C-2. V.35 Cable Pinouts (2 of 3)

100-Pin Plug	Net Name	MS34 Socket	Pin Number	Net Name
67	PORT2_CTS_H	Port 2	D	CTS
N/C				N/C
16	PORT2_LSD_H	Port 2	F	RLSD
N/C				N/C
15	PORT2_DTR	Port 2	H	DTR
66	PORT2_DSR	Port 2	E	DSR
18	PORT2_TM	Port 2	NN	TM
N/C				N/C
63	PORT2_LL	Port 2	L	LL
68	GND	Port 2	B	GND
19	PORT2_RL	Port 2	N	RL
74	GND	Port 2	B	GND
		Port 2	J	CI
		Port 2	B	GND
32	PORT3_TD_H	Port 3	P	TD(A)
81	PORT3_TD_L	Port 3	S	TD(B)
34	PORT3_TXC_H	Port 3	Y	TXC(A)
83	PORT3_TXC_L	Port 3	AA	TXC(B)
36	PORT3_RD_H	Port 3	R	RD(A)
85	PORT3_RD_L	Port 3	T	RD(B)
35	PORT3_RXC_H	Port 3	V	RXC(A)
84	PORT3_RXC_L	Port 3	X	RXC(B)
33	PORT3_TT_H	Port 3	U	XTXC(A)
82	PORT3_TT_L	Port 3	W	XTXC(B)
76	PORT3_RTS_H	Port 3	C	RTS
N/C				N/C
79	PORT3_CTS_H	Port 3	D	CTS
N/C				N/C
28	PORT3_LSD_H	Port 3	F	RLSD
N/C				N/C
27	PORT3_DTR	Port 3	H	DTR
78	PORT3_DSR	Port 3	E	DSR
30	PORT3_TM	Port 3	NN	TM
N/C				N/C
75	PORT3_LL	Port 3	L	LL
80	GND	Port 3	B	GND
31	PORT3_RL	Port 3	N	RL
86	GND	Port 3	B	GND
		Port 3	J	CI
		Port 3	B	GND
44	PORT4_TD_H	Port 4	P	TD(A)
93	PORT4_TD_L	Port 4	S	TD(B)

Table C-2. V.35 Cable Pinouts (3 of 3)

100-Pin Plug	Net Name	MS34 Socket	Pin Number	Net Name
46	PORT4_TXC_H	Port 4	Y	TXC(A)
95	PORT4_TXC_L	Port 4	AA	TXC(B)
48	PORT4_RD_H	Port 4	R	RD(A)
97	PORT4_RD_L	Port 4	T	RD(B)
47	PORT4_RXC_H	Port 4	V	RXC(A)
96	PORT4_RXC_L	Port 4	X	RXC(B)
45	PORT4_TT_H	Port 4	U	XTXC(A)
94	PORT4_TT_L	Port 4	W	XTXC(B)
88	PORT4_RTS_H	Port 4	C	RTS
N/C				N/C
91	PORT4_CTS_H	Port 4	D	CTS
N/C				N/C
40	PORT4_LSD_H	Port 4	F	RLSD
N/C				N/C
39	PORT4_DTR	Port 4	H	DTR
90	PORT4_DSR	Port 4	E	DSR
42	PORT4_TM	Port 4	NN	TM
N/C				N/C
87	PORT4_LL	Port 4	L	LL
92	GND	Port 4	B	GND
43	PORT4_RL	Port 4	N	RL
98	GND	Port 4	B	GND
		Port 4	J	CI
		Port 4	B	GND
100-Pin Plug	Shield	Port 1	A	SHIELD
		Port 2	A	SHIELD
		Port 3	A	SHIELD
		Port 4	A	SHIELD

100-Pin Plug-to-Four DB37 Receptacle RS-449 Cable

Each row of the following table represents pins that are connected to each other.

Table C-3. RS-449 Cable Pinouts (1 of 3)

100-Pin Plug	Net Name	DB37 Socket	Pin Number	Net Name
8	PORT1_TD_H	Port 1	4	SD(A)
57	PORT1_TD_L	Port 1	22	SD(B)
10	PORT1_TXC_H	Port 1	5	ST(A)
59	PORT1_TXC_L	Port 1	23	ST(B)
12	PORT1_RD_H	Port 1	6	RD(A)
61	PORT1_RD_L	Port 1	24	RD(B)
11	PORT1_RXC_H	Port 1	8	RT(A)
60	PORT1_RXC_L	Port 1	26	RT(B)
9	PORT1_TT_H	Port 1	17	TT(A)
58	PORT1_TT_L	Port 1	35	TT(B)
52	PORT1_RTS_H	Port 1	7	RS(A)
2	PORT1_RTS_L	Port 1	25	RS(B)
55	PORT1_CTS_H	Port 1	9	CS(A)
5	PORT1_CTS_L	Port 1	27	CS(B)
4	PORT1_LSD_H	Port 1	13	RR(A)
53	PORT1_LSD_L	Port 1	31	RR(B)
54	PORT1_DSR	Port 1	11	DM(A)
3	PORT1_DTR	Port 1	12	TR(A)
6	PORT1_TM	Port 1	18	TM
1	GND	Port 1	20	GND
51	PORT1_LL	Port 1	10	LL
56	GND	Port 1	19	GND
7	PORT1_RL	Port 1	14	RL
62	GND	Port 1	37	GND
		Port 1	29	DM(B)
		Port 1	20	GND
		Port 1	37	GND
		Port 1	15	IC
20	PORT2_TD_H	Port 2	4	SD(A)
69	PORT2_TD_L	Port 2	22	SD(B)
22	PORT2_TXC_H	Port 2	5	ST(A)
71	PORT2_TXC_L	Port 2	23	ST(B)
24	PORT2_RD_H	Port 2	6	RD(A)
73	PORT2_RD_L	Port 2	24	RD(B)
23	PORT2_RXC_H	Port 2	8	RT(A)
72	PORT2_RXC_L	Port 2	26	RT(B)
21	PORT2_TT_H	Port 2	17	TT(A)
70	PORT2_TT_L	Port 2	35	TT(B)
64	PORT2_RTS_H	Port 2	7	RS(A)

Table C-3. RS-449 Cable Pinouts (2 of 3)

100-Pin Plug	Net Name	DB37 Socket	Pin Number	Net Name
14	PORT2_RTS_L	Port 2	25	RS(B)
67	PORT2_CTS_H	Port 2	9	CS(A)
17	PORT2_CTS_L	Port 2	27	CS(B)
16	PORT2_LSD_H	Port 2	13	RR(A)
65	PORT2_LSD_L	Port 2	31	RR(B)
66	PORT2_DSR	Port 2	11	DM(A)
15	PORT2_DTR	Port 2	12	TR(A)
18	PORT2_TM	Port 2	18	TM
13	GND	Port 2	20	GND
63	PORT2_LL	Port 2	10	LL
68	GND	Port 2	19	GND
19	PORT2_RL	Port 2	14	RL
74	GND	Port 2	37	GND
		Port 2	29	DM(B)
		Port 2	20	GND
		Port 2	37	GND
		Port 2	15	IC
32	PORT3_TD_H	Port 3	4	SD(A)
81	PORT3_TD_L	Port 3	22	SD(B)
34	PORT3_TXC_H	Port 3	5	ST(A)
83	PORT3_TXC_L	Port 3	23	ST(B)
36	PORT3_RD_H	Port 3	6	RD(A)
85	PORT3_RD_L	Port 3	24	RD(B)
35	PORT3_RXC_H	Port 3	8	RT(A)
84	PORT3_RXC_L	Port 3	26	RT(B)
33	PORT3_TT_H	Port 3	17	TT(A)
82	PORT3_TT_L	Port 3	35	TT(B)
76	PORT3_RTS_H	Port 3	7	RS(A)
26	PORT3_RTS_L	Port 3	25	RS(B)
79	PORT3_CTS_H	Port 3	9	CS(A)
29	PORT3_CTS_L	Port 3	27	CS(B)
28	PORT3_LSD_H	Port 3	13	RR(A)
77	PORT3_LSD_L	Port 3	31	RR(B)
78	PORT3_DSR	Port 3	11	DM(A)
27	PORT3_DTR	Port 3	12	TR(A)
30	PORT3_TM	Port 3	18	TM
25	GND	Port 3	20	GND
75	PORT3_LL	Port 3	10	LL
80	GND	Port 3	19	GND
31	PORT3_RL	Port 3	14	RL
86	GND	Port 3	37	GND
		Port 3	29	DM(B)
		Port 3	20	GND

Table C-3. RS-449 Cable Pinouts (3 of 3)

100-Pin Plug	Net Name	DB37 Socket	Pin Number	Net Name
		Port 3	37	GND
		Port 3	15	IC
44	PORT4_TD_H	Port 4	4	SD(A)
93	PORT4_TD_L	Port 4	22	SD(B)
46	PORT4_TXC_H	Port 4	5	ST(A)
95	PORT4_TXC_L	Port 4	23	ST(B)
48	PORT4_RD_H	Port 4	6	RD(A)
97	PORT4_RD_L	Port 4	24	RD(B)
47	PORT4_RXC_H	Port 4	8	RT(A)
96	PORT4_RXC_L	Port 4	26	RT(B)
45	PORT4_TT_H	Port 4	17	TT(A)
94	PORT4_TT_L	Port 4	35	TT(B)
88	PORT4_RTS_H	Port 4	7	RS(A)
38	PORT4_RTS_L	Port 4	25	RS(B)
91	PORT4_CTS_H	Port 4	9	CS(A)
41	PORT4_CTS_L	Port 4	27	CS(B)
40	PORT4_LSD_H	Port 4	13	RR(A)
89	PORT4_LSD_L	Port 4	31	RR(B)
90	PORT4_DSR	Port 4	11	DM(A)
39	PORT4_DTR	Port 4	12	TR(A)
42	PORT4_TM	Port 4	18	TM
37	GND	Port 4	20	GND
87	PORT4_LL	Port 4	10	LL
92	GND	Port 4	19	GND
43	PORT4_RL	Port 4	14	RL
98	GND	Port 4	37	GND
		Port 4	29	DM(B)
		Port 4	20	GND
		Port 4	37	GND
		Port 4	15	IC
49	CABLE_ID			
37	GND			
100-Pin Plug	Shield	Port 1	1	SHIELD
		Port 2	1	SHIELD
		Port 3	1	SHIELD
		Port 4	1	SHIELD

100-Pin Plug-to-Four DB15 Receptacle X.21 Cable

Each row of the following table represents pins that are connected to each other.

Table C-4. X.21 Cable Pinouts (1 of 2)

100-Pin Plug	Net Name	DB15 Socket	Pin Number	Net Name
8	PORT1_TD_H	Port 1	2	TD(A)
57	PORT1_TD_L	Port 1	9	TD(B)
12	PORT1_RD_H	Port 1	4	RD(A)
61	PORT1_RD_L	Port 1	11	RD(B)
11	PORT1_RXC_H	Port 1	6	RXC(A)
60	PORT1_RXC_L	Port 1	13	RXC(B)
9	PORT1_TT_H	Port 1	7	TT(A)
58	PORT1_TT_L	Port 1	14	TT(B)
52	PORT1_RTS_H	Port 1	3	RTS(A)
2	PORT1_RTS_L	Port 1	10	RTS(B)
4	PORT1_LSD_H	Port 1	5	RLSD(A)
53	PORT1_LSD_L	Port 1	12	RLSD(B)
56	GND	Port 1	8	GND
N/C				N/C
20	PORT2_TD_H	Port 2	2	TD(A)
69	PORT2_TD_L	Port 2	9	TD(B)
24	PORT2_RD_H	Port 2	4	RD(A)
73	PORT2_RD_L	Port 2	11	RD(B)
23	PORT2_RXC_H	Port 2	6	RXC(A)
72	PORT2_RXC_L	Port 2	13	RXC(B)
21	PORT2_TT_H	Port 2	7	TT(A)
70	PORT2_TT_L	Port 2	14	TT(B)
64	PORT2_RTS_H	Port 2	3	RTS(A)
14	PORT2_RTS_L	Port 2	10	RTS(B)
16	PORT2_LSD_H	Port 2	5	RLSD(A)
65	PORT2_LSD_L	Port 2	12	RLSD(B)
68	GND	Port 2	8	GND
N/C				N/C
32	PORT3_TD_H	Port 3	2	TD(A)
81	PORT3_TD_L	Port 3	9	TD(B)
36	PORT3_RD_H	Port 3	4	RD(A)
85	PORT3_RD_L	Port 3	11	RD(B)
35	PORT3_RXC_H	Port 3	6	RXC(A)
84	PORT3_RXC_L	Port 3	13	RXC(B)
33	PORT3_TT_H	Port 3	7	TT(A)
82	PORT3_TT_L	Port 3	14	TT(B)
76	PORT3_RTS_H	Port 3	3	RTS(A)
26	PORT3_RTS_L	Port 3	10	RTS(B)
28	PORT3_LSD_H	Port 3	5	RLSD(A)

Table C-4. X.21 Cable Pinouts (2 of 2)

100-Pin Plug	Net Name	DB15 Socket	Pin Number	Net Name
77	PORT3_LSD_L	Port 3	12	RLSD(B)
80	GND	Port 3	8	GND
N/C				N/C
44	PORT4_TD_H	Port 4	2	TD(A)
93	PORT4_TD_L	Port 4	9	TD(B)
48	PORT4_RD_H	Port 4	4	RD(A)
97	PORT4_RD_L	Port 4	11	RD(B)
47	PORT4_RXC_H	Port 4	6	RXC(A)
96	PORT4_RXC_L	Port 4	13	RXC(B)
45	PORT4_TT_H	Port 4	7	TT(A)
94	PORT4_TT_L	Port 4	14	TT(B)
88	PORT4_RTS_H	Port 4	3	RTS(A)
38	PORT4_RTS_L	Port 4	10	RTS(B)
40	PORT4_LSD_H	Port 4	5	RLSD(A)
89	PORT4_LSD_L	Port 4	12	RLSD(B)
92	GND	Port 4	8	GND
N/C				N/C
49	CABLE_ID			
37	GND			
100-Pin Plug	Shield	Port 1	1	SHIELD
		Port 2	1	SHIELD
		Port 3	1	SHIELD
		Port 4	1	SHIELD

Technical Specifications

D

Specifications	Criteria*												
Size	Length 10 inches (25.4 cm) Height 12.3 inches (31.1 cm) Width 0.8 inch (2.0 cm)												
Weight	Approximately 1.3 lbs. (0.6 kg)												
Approvals Safety Certifications	Refer to the equipment's label for approvals on product.												
Power	The Hotwire 8775 Termination Unit contains a dc-to-dc converter that requires -48V power input. The -48V power is distributed through the Hotwire DSLAM backplane. Maximum Power Dissipation = 19 watts												
Cables and Cable Guide	<table border="1"> <thead> <tr> <th>Part Number</th> <th>Description</th> </tr> </thead> <tbody> <tr> <td>8700-F1-500</td> <td>Cable Guide for 8800 DSLAM</td> </tr> <tr> <td>8700-F1-501</td> <td>V.35: 100-Pin Plug to Four MS34 Receptacles</td> </tr> <tr> <td>8700-F1-502</td> <td>X.21: 100-Pin Plug to Four DB15 Receptacles</td> </tr> <tr> <td>8700-F1-503</td> <td>RS449: 100-Pin Plug to Four DB37 Receptacles</td> </tr> <tr> <td>8700-F1-504</td> <td>EIA-530-A: 100-Pin Plug to Four DB25 Receptacles</td> </tr> </tbody> </table>	Part Number	Description	8700-F1-500	Cable Guide for 8800 DSLAM	8700-F1-501	V.35: 100-Pin Plug to Four MS34 Receptacles	8700-F1-502	X.21: 100-Pin Plug to Four DB15 Receptacles	8700-F1-503	RS449: 100-Pin Plug to Four DB37 Receptacles	8700-F1-504	EIA-530-A: 100-Pin Plug to Four DB25 Receptacles
Part Number	Description												
8700-F1-500	Cable Guide for 8800 DSLAM												
8700-F1-501	V.35: 100-Pin Plug to Four MS34 Receptacles												
8700-F1-502	X.21: 100-Pin Plug to Four DB15 Receptacles												
8700-F1-503	RS449: 100-Pin Plug to Four DB37 Receptacles												
8700-F1-504	EIA-530-A: 100-Pin Plug to Four DB25 Receptacles												
Physical Environment Operating temperature Storage temperature Relative humidity Shock and vibration	32° to 122° F (0° to 50° C) -4° F (-20° C) to 158° F (70° C) 5% to 85% (noncondensing) Withstands normal shipping and handling.												
* Technical specifications are subject to change without notice.													

Glossary

511	A random bit test 511 bytes in length.
AIS	Alarm Indication Signal. A signal transmitted downstream instead of the normal signal to preserve transmission continuity and to indicate to the rest of the network that a fault exists. Also called a Blue Alarm.
AMI	Alternate Mark Inversion. A line coding technique used to accommodate the ones density requirements of E1 or T1 lines.
ATI	Asynchronous Terminal Interface. A menu-driven, VT100-compatible system for configuring and managing the termination unit.
BPV	Bipolar Violation. In a bipolar signal, a one (mark, pulse) which has the same polarity as its predecessor.
bridged tap	Any part of the local loop that is not in the direct talking path between the CO and the service user.
CAP	Carrierless Amplitude and Phase Modulation. A transmission technology for implementing a DSL. Transmit and receive signals are modulated into two wide-frequency bands using passband modulation techniques.
CD	Carrier Detect. The received line signal detector. V.24 circuit 109.
CO	Central Office/Central Site. The PSTN facility that houses one or more switches serving local telephone subscribers.
COM port	Communications port. A computer's serial communications port used to transmit to and receive data from a modem. The modem connects directly to this port.
CP	Customer Premises.
CPE	Customer Premises Equipment. Terminal equipment on the service user's side of the telecommunications network interface.
CPU	Central Processing Unit. The main or only computing device in a data processing system.
CRC	Cyclic Redundancy Check. A mathematical method of confirming the integrity of received digital data.
CTS	Clear To Send. A signal indicating that the device is ready for the DTE to transmit data. Usually occurs in response to Request To Send (RTS).
CV	Code Violation. Detected when using HDB3 coding format, this is equivalent to a BPV when using AMI coding.
DCE	Data Communications Equipment. The equipment that provides the functions required to establish, maintain, and end a connection. It also provides the signal conversion required for communication between the DTE and the network.
DCLB	Data Channel LoopBack. Loops the data received from the network interface, for all DS0 channels allocated to the selected port, back to the network.
DSL	Digital Subscriber Line. The non-loaded, local-loop copper connection between the customer and the first node within the network.

DSLAM	Digital Subscriber Line Access Multiplexer. A platform for DSL modems that provides high-speed data transmission over traditional twisted-pair wiring.
DSR	Data Set Ready. A signal from the modem to the DTE that indicates the modem is turned ON and connected to the DTE.
DSX-1	Digital Signal Cross Connect level 1. An interconnection point for terminals, multiplexers and transmission facilities.
DTE	Data Terminal Equipment. The equipment, such as a computer or terminal, that provides data in the form of digital signals for transmission.
DTLB	Data Terminal LoopBack. Loopback mode that loops the data for a particular synchronous data port back to the port just before it is combined with the rest of the T1 data stream.
DTR	Data Terminal Ready. A signal from the DTE to the modem, sent via Pin 20 of the EIA-232 interface (V.24 circuit 108/1, /2), that indicates the DTE is turned ON and connected to the modem.
E1	A wideband digital interface operating at 2.048 Mbps, defined by ITU recommendations G.703 and G.704. It is used primarily outside North America.
EER	Excessive Error Rate. An error rate that is greater than the threshold that has been configured in the device.
EIA-530-A	An Electronic Industries Association standard for a high-speed, 25-position, DCE/DTE interface.
EOC	Embedded Operations Channel. An in-band channel between DSL devices, used for 8 kbps management data.
ES	Errored Seconds. A second with one or more error events (one or more CRC error events or OOFs).
ESF	Extended SuperFrame. The T1 transmission standard that specifies 24 frames as an extended superframe to be used for frame synchronization and to locate signaling bits.
Ethernet	A type of network that supports high-speed communication among systems. It is a widely implemented standard for LANs. All hosts are connected to a coaxial cable where they contend for network access using a Carrier Sense, Multiple Access with Collision Detection (CSMA/CD) paradigm.
ETSI	European Telecommunications Standardization Institute. An organization that produces technical standards in the area of telecommunications.
factory defaults	A predetermined set of configuration options containing the optimum settings for operation on asynchronous dial networks.
FAS	Frame Alignment Signal. A loss of frame (LOF) error detection.
FAW	Frame Alignment Word. A loss of synchronization error detection.
FCC	Federal Communications Commission. The Board of Commissioners that regulates all electrical communications that originate in the United States.
FDL	Facility Data Link. The selected framing bits in the ESF format used in a wide-area link that are used for control, monitoring, and testing.
FEBE	Far-End Block Error. Block errors reported by remote equipment.
frame	One identifiable group of data bits that includes a sequence of bits for control and identification information.
framer	A program or device that assembles and disassembles frames.

frame relay	A high-speed connection-oriented packet switching WAN protocol using variable-length frames.
FTP	File Transfer Protocol. A TCP/IP standard protocol that allows a user on one host to access and transfer files to and from another host over a network, provided that the client supplies a login identifier and password to the server.
G.703	An ITU recommendation for the physical and logical characteristics of hierarchical digital devices.
G.704	An ITU recommendation for synchronous frame structures.
HDB3	High Density Bipolar Three Zeros Substitution. A line coding technique used to accommodate the ones density requirements of E1 lines.
HDSL	High-bit-rate Digital Subscriber Line. A technique for high bandwidth, bidirectional transmission over copper wire for T1 and E1 services.
IP	Internet Protocol. An open networking protocol used for internet packet delivery.
IP address	Internet Protocol address. The address assigned to an internet host.
LAN	Local Area Network. A privately owned and administered data communications network limited to a small geographic area.
LED	Light Emitting Diode. A light or status indicator that glows in response to the presence of a certain condition (e.g., an alarm).
LIU	Line Interface Unit. A physical layer data transmitter and receiver.
LLB	Line LoopBack. A test in which the received signal on the network interface is looped back to the network without change.
loopback	A diagnostic procedure that sends a test message back to its origination point. Used to test various portions of a data link in order to isolate an equipment or data line problem.
LOS	Loss of Signal. The line condition where there are no pulses.
LTU	Line Termination Unit. The control unit on the network end of a link. (The NTU is on the customer premises end.)
MCC	Management Communications Controller. The DSLAM circuit card used to configure and monitor the DSLAM.
M/HDSL	Multirate High-bit-rate Digital Subscriber Line. (See HDSL.)
MIB	Management Information Base. A database of managed objects used by SNMP to provide network management information and device control.
MIB II	MIB Release 2. The current Internet-standard MIB, defined by RFC 1213.
M/SDSL	Multirate Symmetric Digital Subscriber Line. (See SDSL.)
MTSO	Mobile Telephone Switching Office. A generic name for the main cellular switching center which supports multiple base stations.
NMS	Network Management System. A computer system used for monitoring and controlling network devices.
NTU	Network Termination Unit. The unit on the customer premises end of a link. (The LTU is on the network end.)
OOF	Out Of Frame. An error condition in which frame synchronization bits are in error.
PPP	Point-to-Point Protocol. A protocol for packet transmission over serial links, specified by Internet RFC 1661.

receiver	A circuit that accepts data signals from a transmitter.
reset	A reinitialization of the device that occurs at power-up or in response to a reset command.
RLB	Repeater LoopBack. Loops the signal being sent to the network back to the DTE Drop/Insert and data ports after it has passed through the framing circuitry of the device.
router	A device that connects LANs by dynamically routing data according to destination and available routes.
RS-449	An Electronic Industries Association's standard for a general-purpose, 37-position, DCE/DTE interface.
RTS	Request to Send. A signal from the DTE to the device, indicating that the DTE has data to send. V.24 circuit 105.
RXD	Received Data. Pin 3 of the EIA-232 interface that is used by the DTE to receive data from the modem. Conversely, the modem uses Pin 3 to transmit data to the DTE.
SDSL	Symmetric Digital Subscriber Line. A technique for the use of an existing twisted-pair line that permits high bandwidth, bidirectional transmission.
SES	Severely Errored Seconds. Usually defined as a second during which a specific number of CRC errors was exceeded, or an OOF or other critical error occurred.
SNMP	Simple Network Management Protocol. Protocol for open networking management.
T1	A term for a digital carrier facility used to transmit a DS1 formatted digital signal at 1.544 Mbps. It is used primarily in North America.
TCP/IP	Transmission Control Protocol/Internet Protocol. The dominant protocol suite in the worldwide Internet, TCP allows a process on one machine to send data to a process on another machine using the IP. TCP can be used as a full-duplex or one-way simplex connection.
Telnet	Virtual terminal protocol in the Internet suite of protocols. Allows the user of one host computer to log into a remote host computer and interact as a normal terminal user for that host.
TFTP	Trivial File Transfer Protocol. A standard TCP/IP protocol that allows simple file transfer to and from a remote system without directory or file listing. TFTP is used where FTP is not available.
transceiver	A circuit capable of acting as both a transmitter and a receiver.
transmitter	A circuit capable of generating, modulating, and sending a signal for communication, control, and other purposes.
TXD	Transmit Data. Pin 2 of the EIA-232 interface that is used by the DTE to transmit data to the modem. Conversely, the modem uses Pin 2 to receive data from the DTE.
UNIX	An operating system developed at AT&T Bell Laboratories and since used as the basis of similar operating systems.
V.35	An ITU-T standard for a high-speed, 34-position, DCE/DTE interface.
WAN	Wide Area Network. A network that spans a large geographic area.
X.21	An ITU-T standard for a high-speed, 15-position, DCE/DTE interface.
Yellow Alarm	An outgoing signal transmitted when a DS1 or DS3 terminal has determined that it has lost the incoming signal.

Index

A

- Abort All Tests, 5-1
- access
 - SNMP, 7-5
 - to async terminal interface, 2-3
- access level
 - effective, 7-2
 - functions available for, 7-2
- Action on Network LOS Alarm, A-6
- administer login, 7-3
- Alarm, LED, 4-10
- ASCII, printable characters, 3-2
- ATI (Asynchronous Terminal Interface)
 - access, 2-1
 - defined, 1-2
 - exiting, 2-9
 - initiating session, 2-2
 - virtual function keys, 2-7
- authenticationFailure, B-1
- AutoRate, 3-6, A-2
 - ceiling (DSL Line Rate), A-3

C

- cables, part numbers, D-1
- Card Failed
 - self-test result, 4-5
 - status message, 4-4
- Circuit Identifier, A-3
- clocking, A-5
- Community Name 1, A-11
- Community Name 2, A-11
- community names, for SNMP, 7-5
- Configuring AutoRate, 3-6
- configuration
 - example, 1-3
 - General SNMP Management Options, A-11
 - option tables, A-1
 - SNMP Management, A-11
 - SNMP NMS Security Options, A-12
 - SNMP Traps Options, A-13
- configuration changes, saving, 3-9
- Configuration Edit/Display, 3-5

- Configuration Loader, 3-7
- Configuration menu, 3-4
- configuration options
 - Copy Ports, A-7
 - SYNC Ports, A-4
 - System Options, A-8
- Copy Ports, A-7
- CPU Fail, self-test result, 4-5
- create login ID, 7-3
- customer configuration areas, 3-3

D

- data channel loopback (DCLB), 5-9, A-6
- data port loopbacks, DTE initiated, A-6
- data port tests, 5-7
- data terminal loopback (DTLB), 5-8, A-6
- default configuration area, 3-3
- delete, Login ID, 7-4
- device
 - messages, 6-3–6-4
 - name, 3-2
- dimensions, D-1
- Disconnect Time, for Telnet session, A-10
- documents, related, vi
- DOS, TFTP server on, 3-8
- download code, 3-10
- Download Failed, status message, 4-4
- DSL Line Rate, A-3
 - Fixed Rate, 3-7
- DSL Mode, A-8
- DSL Port, LEDs, 4-10
- DSLAM
 - defined, 1-2
 - exiting from session, 2-9
 - login, 2-2
- DTE port tests, 5-7
- DTE-initiated loopbacks, A-6

E

EER (Excessive Error Rate) , status message, 4-3
effective access level, 7-2
ElasticStore, A-6
ending an ATI session, 2-9
enterprise, SNMP traps, B-3
environment requirements, D-1
error messages, line 24, 6-3
error statistics, 4-6
Excessive Error Rate (EER) Threshold, A-2

F

factory defaults, 3-3
Failure, self-test result, 4-5
feature numbers, D-1
features, 1-2
firmware, download from server, 3-10

G

General SNMP Management Options, A-11
glossary, GL-1–GL-4

H

health and status messages, 4-3

I

identity, 3-2
inactivity timeout, for Telnet session, A-10
intended audience, v
invert transmit clock, A-5
IP address
 DSL peer, A-3
 example, 8-2
 selecting, 8-1
 SNMP manager, 7-5

K

keyboard functions, 2-6

L

lamp test, 5-11
LEDs, 4-9, 4-10
Link Up, LEDs, 4-10
link-layer protocols, 8-1
linkUp and linkDown traps, B-2
local line loopback (LLB), 5-3
login, DSLAM, 2-2
Login ID
 access levels, 7-2
 adding, 7-3
 deleting, 7-4
login ID, 7-1
loopback, effect on LEDs, 4-10
LOS (Loss Of Signal), status message, 4-3
LOS alarm action, A-6

M

main menu, 2-2, A-1
Management and Communication Options, A-9
management port
 access, 7-1
 settings, 2-1
Margin Threshold, A-2
MCC, defined, 1-2
Memory Fail, status, 4-5
messages
 alarm and device, 6-1
 health and status, 4-3
 line 24, 6-3
 self-test results, 4-5
 test status, 4-5
MIB
 general support, 1-4
 support, 1-4
monitoring, 4-1

N

- navigating the screens, 2-6
- Net Margin Threshold, status message, 4-3
- network
 - interface options, A-2
 - tests, 5-2
- Network DSL Failed, self-test result, 4-5
- Network-Initiated DCLB, A-6
- NMS
 - IP address, A-12
 - SNMP access, 7-5
 - SNMP connectivity, 8-1
- no test active status message, 4-5

O

- OK, LED, 4-10
- OOB (Out Of Frame), status message, 4-3
- options, configuration tables, A-1
- overview
 - 8775 Termination Unit, 1-2
 - user's guide, v

P

- part numbers, D-1
- Passed, self-test result, 4-5
- Payload Rate, A-4
- payload rates, and DSL Line Rate, A-3
- Peer IP Address, A-3
- performance statistics, 4-7
- physical environment requirements, D-1
- pin assignments, C-1
- Port Status, A-4
- power requirements, D-1

R

- related documents, vi
- remote send line loopback, 5-5
- repeater loopback (RLB), 5-4
- reset, ATI, 3-10
- restore access to ATI, 3-10

S

- Save Configuration screen, 3-9
- saving option changes, 3-9
- screen, function keys, 2-7
- screens, for user interface, 2-1– 2-6
- security, 7-1
- self-test results, 4-5
- Send and Monitor 511, 5-6
- Send Ones configuration option, A-5
- Send Remote DCLB Loopback, 5-10
- size of card, D-1
- SNMP
 - system entries, 3-2
 - trap options, 6-2
 - traps, B-1
- SNMP management
 - configuration options, A-11
 - enable/disable, A-11
 - general, 1-4
 - limiting access, 7-5
- SNMP NMS Security Options, A-12
- SNMP Traps Options, A-13
- start-up, ATI, 2-1
- status, test messages, 4-5
- SYNC Data Port Tests, 5-7
- Sync Port, LEDs, 4-10
- SYNC Ports Options, A-4
- SYNC Pt Down, status message, 4-3
- SYNC Pt Failed, self-test result, 4-5
- system
 - device name fields, 3-2
 - LEDs, 4-10
- System Options, A-8

T

- Telnet session
 - access level, A-10
 - configuration options, A-9
 - enable/disable, A-10
 - inactivity timeout, A-10
 - login required, A-10
- telnet session access, 7-1
- terminal port, direct connection, 2-1

- test, 5-1
 - aborting, 5-12
 - Data Channel Loopback, 5-9
 - Data Terminal Loopback, 5-8
 - LED, 4-10
 - Line Loopback, 5-3
 - menu, 5-1
 - Network-Initiated DCLB, A-6
 - Port (DTE) Initiated Loopbacks, A-6
 - Remote Send Line Loopback, 5-5
 - Repeater Loopback, 5-4
 - Send and Monitor 511, 5-6
 - status messages, 4-5
 - SYNC Data Port, 5-7
 - terminating, 5-12
 - Test Duration, A-8
 - Test Timeout, A-8
- timeout
 - Telnet session inactivity, A-10
 - test duration, A-8
- transmit clock inversion, A-5
- transmit clock source, A-5
- traps, SNMP, 6-2, B-1
- troubleshooting, 6-5
 - error statistics, 4-6
 - performance statistics, 4-7

U

- UNIX, TFTP server on, 3-8
- user interface
 - access, 3-10
 - async terminal, 2-1
 - how to access, 2-1

V

- V.54 Loop 3. *See* data terminal loopback (DTLB)
- virtual function keys, 2-7

W

- warmStart, B-1
- weight of card, D-1