

Hotwire™ 8776 M/SDSL Chassis-Mounted Termination Unit, with G.703 Interface Installation Instructions

Document Number 8776-A2-GZ40-10

August 1998

Hotwire™ 8776 E1 M/SDSL Termination Unit

The Hotwire 8776 Termination Unit is a circuit card assembly (CCA) that contains four E1 Multirate Symmetric Digital Subscriber Line (M/SDSL) ports with a G.703 Interface. When the 8776 Termination Unit is used in a Hotwire 8600 or 8800 Digital Subscriber Line Access Multiplexer (DSLAM) chassis, it transports up to 2048 kbps signals over traditional twisted-pair telephone wiring.

▲ HANDLING PRECAUTIONS FOR STATIC-SENSITIVE DEVICES



This product is designed to protect sensitive components from damage due to electrostatic discharge (ESD) during normal operation. When performing installation procedures, however, take proper static control precautions to prevent damage to equipment. If you are not sure of the proper static control precautions, contact your nearest sales or service representative.

Package Checklist

Verify that your package contains the following:

- Hotwire model 8776 circuit card assembly
- Warranty card
- Hotwire 8776 M/SDSL Termination Unit, with G.703 Interface, User's Guide, Document No. 8776-A2-GB20*

Tool Required

- Small- to medium-size flat-blade screwdriver.

Technical Specifications

Specifications	Criteria*				
Size	Length 10 inches (25.4 cm) Height 12.3 inches (31.1 cm) Width 0.8 inch (2.0 cm)				
Weight	Approximately 1.3 lbs. (0.6 kg)				
Approvals Safety Certifications	Refer to the equipment's label for approvals on product.				
Power	The Hotwire Model 8776 Termination Unit contains a DC-to-DC converter that requires –48V power input. The –48V power is distributed through the Hotwire DSLAM backplane. Maximum Power Dissipation = 19 watts				
Cables and Cable Guide	<table border="1"> <thead> <tr> <th>Part Number</th> <th>Description</th> </tr> </thead> <tbody> <tr> <td>8700-F1-500</td> <td>Cable Guide for 8800 DSLAM</td> </tr> </tbody> </table>	Part Number	Description	8700-F1-500	Cable Guide for 8800 DSLAM
Part Number	Description				
8700-F1-500	Cable Guide for 8800 DSLAM				
Physical Environment Operating temperature Storage temperature Relative humidity Shock and vibration	32° to 122° F (0° to 50° C) –4° F (–20° C) to 158° F (70° C) 5% to 85% (noncondensing) Withstands normal shipping and handling.				
* Technical specifications are subject to change without notice.					

Planning the 8776 Termination Unit Installation

Review the following list to help plan for the installation.

- Obtain the applicable cables; refer to *Cables You Need* on page 3.
- Make sure the Hotwire DSLAM chassis is installed and power is supplied to the chassis.
- After the Hotwire 8776 Termination Unit is installed, there are configuration procedures that must be performed before you can begin to use the termination unit. Refer to the *Hotwire 8776 M/SDSL Termination Unit, with G.703 Interface, User's Guide*, for more detailed configuration procedures.

Cables You Need

The following standard cable is used with this product.

For the network connection:

- Plug-ended Telco 50-pin cable for connection from the Hotwire 8600 DSLAM LINE port or one of the Hotwire 8800 DSLAM LINES ports to the Main Distribution Frame (MDF) or other demarcation point.

For the DTE connection:

- For further information refer to Appendix C, *Connector Pin Assignments*, in the User's Guide.

Installing DSL Cards

Use a small- to medium-size flat-blade screwdriver to install the 8776 Termination Unit.

When installing the unit into a . . .	Place the termination unit in . . .
Hotwire 8600 DSLAM base chassis	Slot 2 or 3 (Slot 1 of the Hotwire 8600 DSLAM base chassis must contain a Management Communications Controller (MCC) card).
Hotwire 8600 DSLAM expansion chassis	Slot 1, 2, or 3.
Hotwire 8800 DSLAM chassis	Any one of the first 18 slots (i.e., Slot 1 through 18).

A Hotwire 8776 Termination Unit can be installed, removed, and replaced from a the DSLAM chassis without disrupting service to the other cards in the chassis.

NOTE:

When installing the Termination Unit, you need to remove the filler plate before proceeding.

Do not discard unused filler plates. Each slot in the chassis must contain a circuit card or a filler plate. Store all unused filler plates in a safe place. You may need to use the filler plates to cover open slots in the chassis at a later time.

► Procedure

To install the Hotwire 8776 Termination Unit:

1. Determine in which slot the Termination Unit will be installed. Verify that cards in adjacent slots have been fastened.
2. Remove the filler plate from the installation slot.
3. Insert the Termination Unit:
 - For a **Hotwire 8600 DSLAM chassis** – hold the 8776 Termination Unit horizontally with component side facing up and insert it into the left and right card guides.

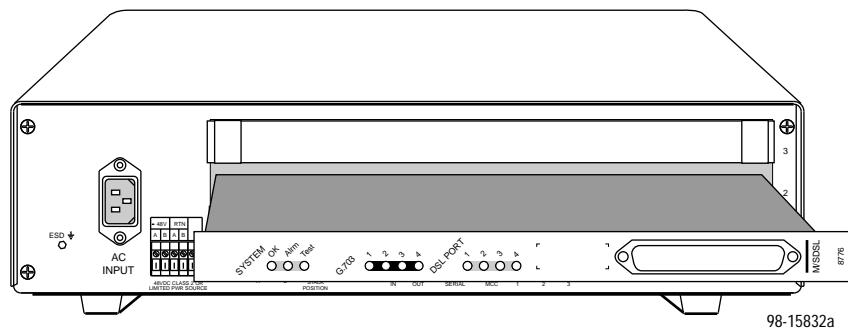

- For a **Hotwire 8800 DSLAM chassis** – hold the 8776 Termination Unit vertically with component side facing right and insert it into the top and bottom card guides.

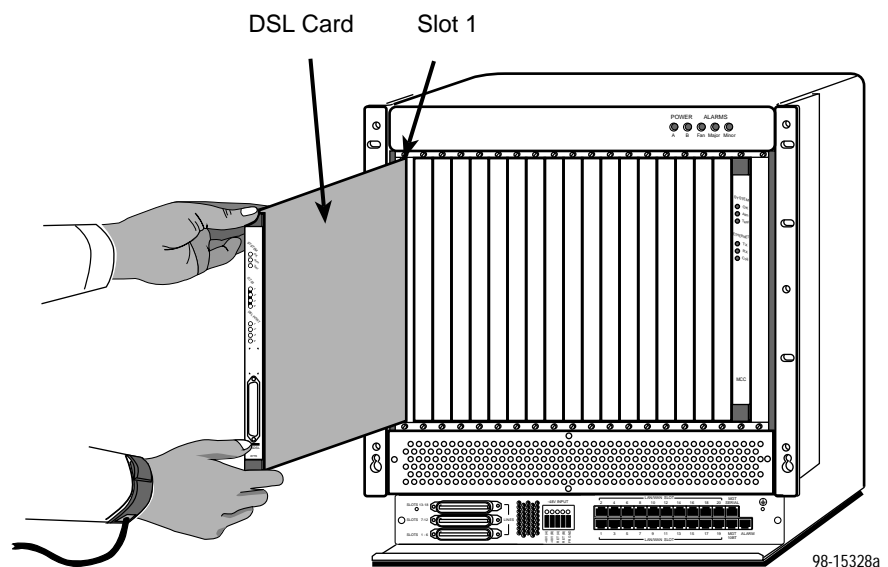

-
- Slide the 8776 Termination Unit into the slot until the power and network connectors seat firmly in the mating connectors on the backplane.

CAUTION:

Do not force the 8776 Termination Unit into the slot. If it does not seat properly, remove the card and reinstall it. If it still does not seat properly, call your service representative.

The 8776 Termination Unit performs a power-up self-test. All of the LEDs turn ON and OFF briefly. When the self-test is completed successfully, the SYSTEM OK LED will turn ON. Make sure the SYSTEM OK indicator on the 8776 Termination Unit faceplate is ON.

- If the LED is not ON, refer to Chapter 6, *Messages and Troubleshooting*, in the User's Guide.
- Secure the 8776 Termination Unit by fastening the screws at each end of the faceplate.

NOTE:

The 8776 Termination Unit may be replaced without system disruption (i.e., you can remove and reinstall a card without powering down the Hotwire DSLAM chassis and disrupting service to the other cards). To remove an 8776 Termination Unit from the Hotwire DSLAM chassis, unfasten the screws on both ends of the faceplate. Then push the ejector handles outward and slide the card out.

Ensure that adjacent cards are fastened before removing a card.

When swapping the old 8776 Termination Unit with a new 8776 Termination Unit, note that the 8600 DSLAM retains the Media Access Control (MAC) address, also referred to as the physical address. This means that the new 8776 Termination Unit will have the same MAC address as the old one.

Cable Management

The optional Cable Guide (see *Technical Specifications* on page 2 for its part number) connects to the front of the Hotwire 8800 DSLAM and provides strain relief and control of the DTE cables. Install the Cable Guide before installing the cables.

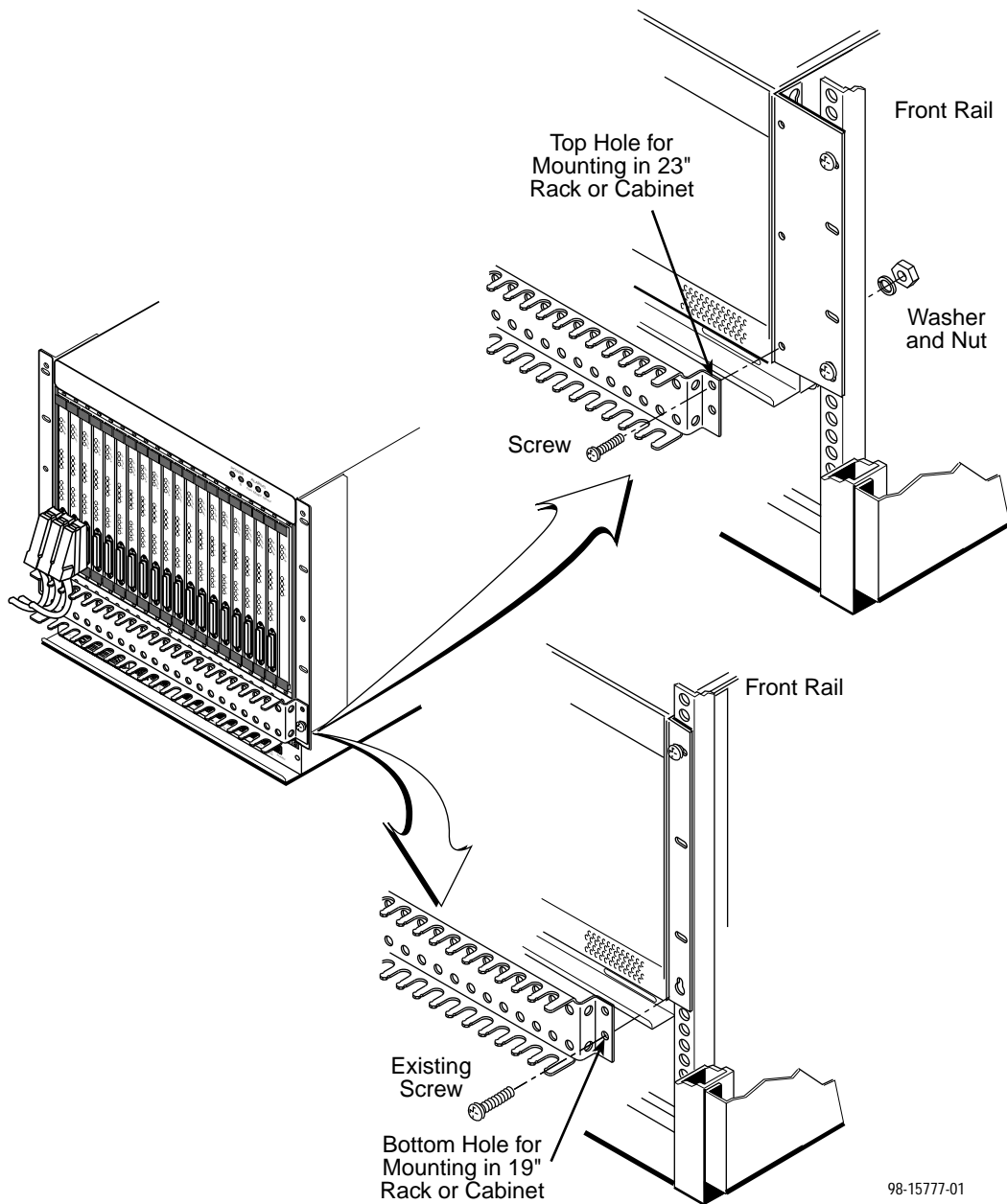

Connecting to the DTE Equipment

Connection to the four ports of the 8776 Termination Unit is through the 50-pin interface connector on its faceplate. Refer to Appendix C, *Connector Pin Assignments*, in the User's Guide.

► Procedure

To connect the Hotwire 8776 Termination Unit to your DTE equipment:

1. Connect the 50-position connector of the cable to the connector on the faceplate of the 8776 Termination Unit. Align one end of the cable connector with the card connector, then push on the cable connector until it seats.

The end of the cable connector has a release button. To remove the connector, press the release button and pull the connector away from the card.

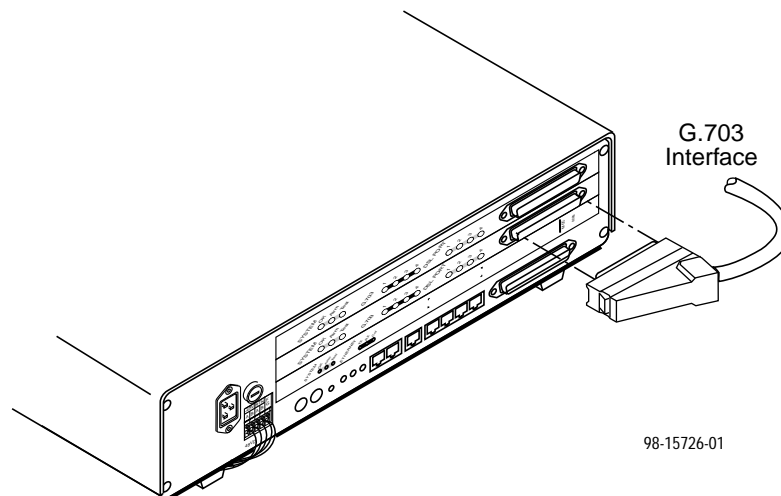

2. Feed the cable through the Cable Guide if it is in use. When all cables are installed, anchor them with cable ties to the rack, DSLAM, or Cable Guide.
3. Connect the four terminating connectors to your DTE equipment.

Connecting to an MDF

You can connect the Hotwire DSLAM chassis containing the 8776 Termination Unit to an MDF or other demarcation point. Do not connect it to a POTS splitter.

► Procedure

To connect the Hotwire DSLAM chassis containing the 8776 Termination Unit to an MDF:

1. Plug the Telco 50-pin cable into the appropriate LINE port on the front panel of the chassis:

— On a Hotwire 8600 DSLAM chassis:

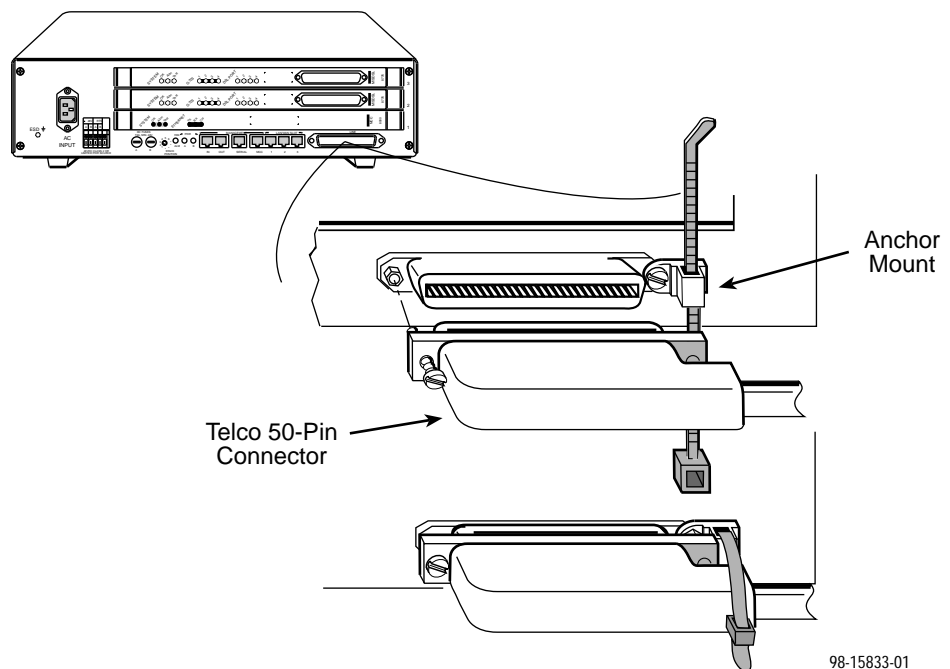

— On a Hotwire 8800 DSLAM chassis:

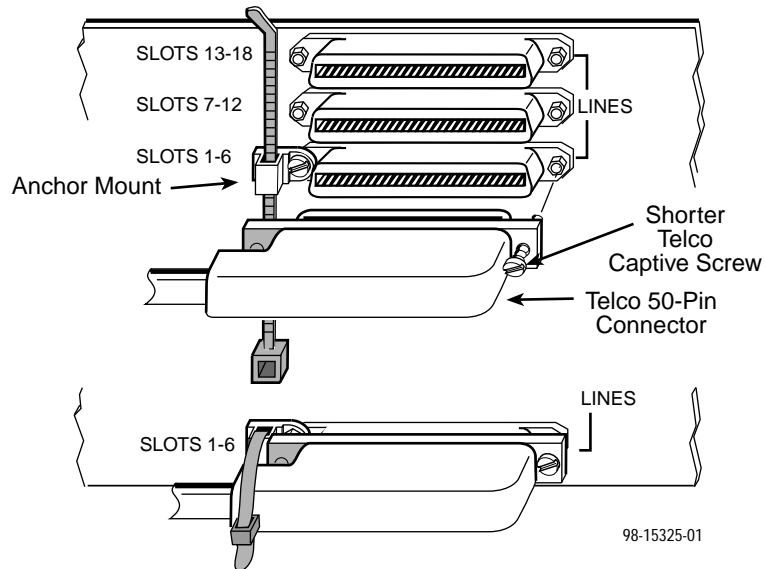

2. Replace the longer Telco cable captive screw with a shorter connector captive screw, which is provided with the Hotwire DSLAM chassis.
3. Insert a cable tie (provided with Hotwire DSLAM chassis) through the tie mount to hold the Telco 50-pin connector in place. If more than one Telco cable is being connected, span the two or three connectors.
4. Make sure the other end is connected to the appropriate MDF or demarcation point.

Refer to Appendix D, *Cables and Pin Assignments*, in the User's Guide for pinouts.

NOTE:

If you are connecting the Telco 25-pair, 50-pin cable to an MDF, a converter may be necessary for terminating the other end of the cable on a punchdown block before cross-connecting to an MDF.

Model 8776 Termination Unit LEDs

The following table describes the meaning and states of the LEDs on the 8776 Termination Unit faceplate.

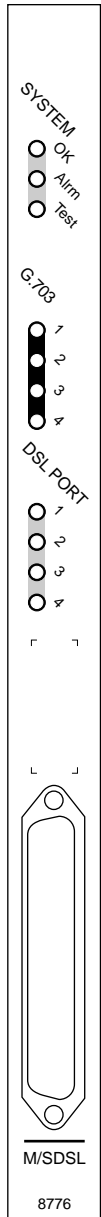

98-16041-01

Type	LED	LED is . . .	Indicating . . .
SYSTEM	OK	Green	Normal operation; termination unit functioning normally.
		Off	No power to termination unit, or failure has occurred.
	Alarm	Amber	Device failure, or Power-On Self-Test (POST) is not complete.
Off		No alarms.	
SYSTEM	Test	Amber	Loopback test or 511 test pattern in progress.
		Amber, flashing	POST in progress.
		Off	No tests currently active.
G.703	1, 2, 3, 4	Green	Recoverable signal present on the G.703 network.
		Amber	Remote Alarm Indication (RAI) present.
		Amber, flashing	An OOF condition exists.
		Off	The DSL LINK is down.
DSL PORT	1, 2, 3, 4	Green	DSL link is up.
		Amber	DSL training in progress.
		Amber, flashing	OOF condition.
		Off	DSL link is down.



8776-A2-GZ40-10