



Hotwire™ 8776 M/SDSL Termination Unit with G.703 Interface Installation Instructions

Document Number 8776-A2-GZ40-20

March 1999

Product Documentation on the World Wide Web

We provide complete product documentation online. This lets you search the documentation for specific topics and print only what you need, reducing the waste of surplus printing. It also helps us maintain competitive prices for our products.

Complete documentation for this product is available at www.paradyne.com.
Select *Library* → *Technical Manuals* → *Hotwire DSL & MVL Systems*.

Select the following document:

8776-A2-GB20

*Hotwire 8776 M/SDSL Termination Unit, with G.703 Interface,
User's Guide*

To request a paper copy of a Paradyne document:

- Within the U.S.A., call 1-800-PARADYNE (1-800-727-2396)
- Outside the U.S.A., call 1-727-530-8623

Hotwire™ 8776 E1 M/SDSL Termination Unit

The Hotwire 8776 Termination Unit is a circuit card assembly (CCA) that contains four E1 Multirate Symmetric Digital Subscriber Line (M/SDSL) ports with a G.703 Interface. When the 8776 Termination Unit is used in a Hotwire 8600 or 8800 Series Digital Subscriber Line Access Multiplexer (DSLAM) chassis, it transports up to 2048 kbps signals over traditional twisted-pair telephone wiring.

⚠ HANDLING PRECAUTIONS FOR STATIC-SENSITIVE DEVICES



This product is designed to protect sensitive components from damage due to electrostatic discharge (ESD) during normal operation. When performing installation procedures, however, take proper static control precautions to prevent damage to equipment. If you are not sure of the proper static control precautions, contact your nearest sales or service representative.

Installation Overview

Installation and configuration of the Hotwire 8776 Termination Unit consists of:

- Installing the Termination Unit in the DSLAM.
- Connecting to the DTE.
- Connecting to an MDF.
- Providing initial unit identity information or changing existing identity information.
- Configuring your unit using the Configuration Edit menus.

Before you install the Hotwire 8776 Termination Unit, read the *Important Safety Instructions* on page 24.

Be sure to register your warranty at www.paradyne.com. Select *Service & Support* → *Warranty Registration*.

Tool Required

- Small- to medium-size flat-blade screwdriver.

Planning the 8776 Termination Unit Installation

Review the following list to help plan for the installation.

- Obtain the applicable cables; refer to *Cables You Need*, below.
- Make sure the Hotwire DSLAM chassis is installed and power is supplied to the chassis.
- After the Hotwire 8776 Termination Unit is installed, there are configuration procedures that must be performed before you can begin to use the termination unit. Refer to the *Hotwire 8776 M/SDSL Termination Unit, with G.703 Interface, User's Guide*, for more detailed configuration procedures.

Cables You Need

The following standard cable is used with this product.

For the network connection:

- Plug-ended Telco 50-pin cable for connection from the Hotwire 8600 DSLAM LINE port or one of the Hotwire 8800 DSLAM LINES ports to the Main Distribution Frame (MDF) or other demarcation point.

For the DTE connection:

- For further information refer to *Connector Pin Assignments* in the User's Guide.

Installing DSL Cards

Use a small- to medium-size flat-blade screwdriver to install the 8776 Termination Unit.

When installing the unit into a . . .	Place the termination unit in . . .
Hotwire 8600 Series DSLAM base chassis	Slot 2 or 3. Slot 1 of the Hotwire 8600 DSLAM base chassis must contain a Management Communications Controller (MCC) card.
Hotwire 8600 Series DSLAM expansion chassis	Slot 1, 2, or 3.
Hotwire 8800 Series DSLAM chassis	Any one of the first 18 slots (i.e., Slot 1 through 18). Slot 19 is reserved for the MCC and Slot 20 is reserved for future use.

A Hotwire 8776 Termination Unit can be installed, removed, and replaced from a the DSLAM chassis without disrupting service to the other cards in the chassis.

NOTE:

When installing the Termination Unit, you need to remove the filler plate before proceeding.

Do not discard unused filler plates. Each slot in the chassis must contain a circuit card or a filler plate. Store all unused filler plates in a safe place. You may need to use the filler plates to cover open slots in the chassis at a later time.

► Procedure

To install the Hotwire 8776 Termination Unit:

1. Determine in which slot the Termination Unit will be installed. Verify that cards in adjacent slots have been fastened.
2. Remove the filler plate from the installation slot.
3. Insert the Termination Unit:
 - For a **Hotwire 8600 Series DSLAM chassis** – hold the 8776 Termination Unit horizontally with component side facing up and insert it into the left and right card guides.

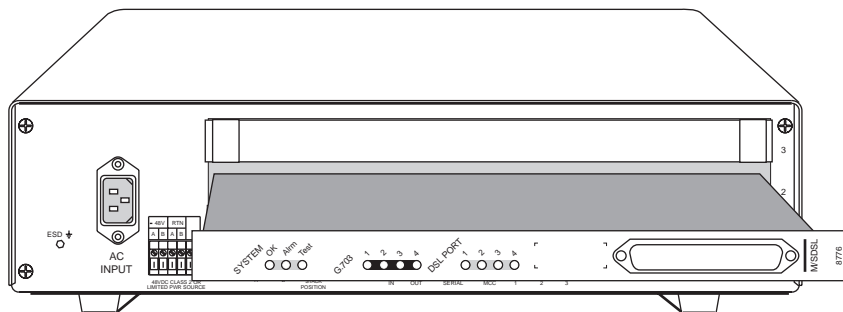

98-15832a

-
- For a **Hotwire 8800 Series DSLAM chassis** – hold the 8776 Termination Unit vertically with component side facing right and insert it into the top and bottom card guides.

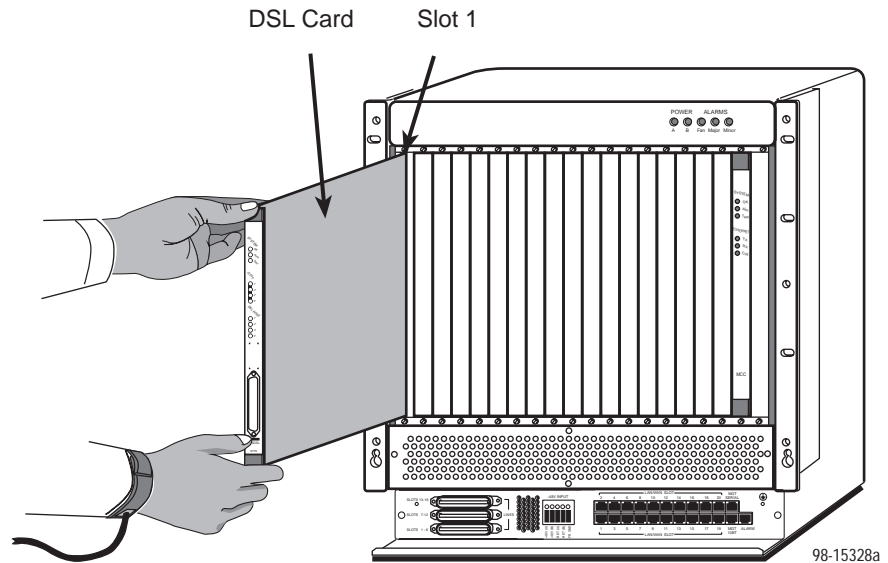

4. Slide the 8776 Termination Unit into the slot until the power and network connectors seat firmly in the mating connectors on the backplane.

CAUTION:

Do not force the 8776 Termination Unit into the slot. This could damage the backplane connectors. If the card does not seat properly, remove the card and reinstall it. If it still does not seat properly, call your service representative.

The 8776 Termination Unit performs a power-up self-test. All of the LEDs turn ON and OFF briefly. When the self-test is completed successfully, the SYSTEM OK LED will turn ON. Make sure the SYSTEM OK indicator on the 8776 Termination Unit faceplate is ON.

5. If the LED is not ON, refer to *Messages and Troubleshooting* in the User's Guide.
6. Secure the 8776 Termination Unit by fastening the screws at each end of the faceplate.

NOTE:

The 8776 Termination Unit may be replaced without system disruption (i.e., you can remove and reinstall a card without powering down the Hotwire DSLAM chassis and disrupting service to the other cards). To remove an 8776 Termination Unit from the Hotwire DSLAM chassis, unfasten the screws on both ends of the faceplate. Then push the ejector handles outward and slide the card out.

When swapping the old 8776 Termination Unit with a new 8776 Termination Unit, note that the 8600 DSLAM retains the Media Access Control (MAC) address, also referred to as the physical address. This means that the new 8776 Termination Unit will have the same MAC address as the old one.

Cable Management

The optional Cable Guide connects to the front of the Hotwire 8800 Series DSLAM and provides strain relief and control of the DTE cables. Install the Cable Guide before installing the cables.

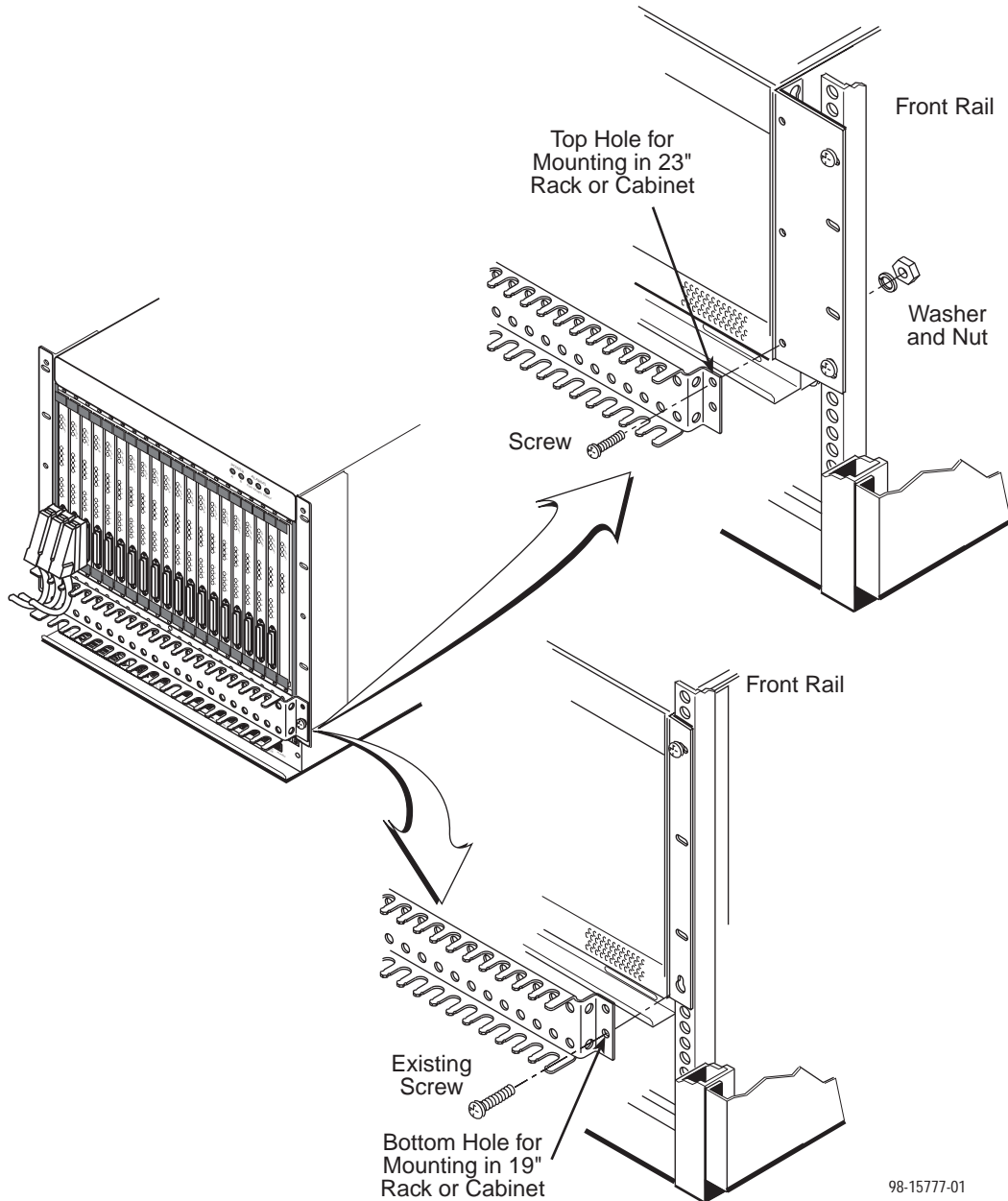

Connecting to the DTE

Connection to the four ports of the 8776 Termination Unit is through the 50-pin interface connector on its faceplate. Refer to *Connector Pin Assignments* in the User's Guide.

► Procedure

To connect the Hotwire 8776 Termination Unit to your DTE:

1. Connect the 50-position connector of the cable to the connector on the faceplate of the 8776 Termination Unit. Align one end of the cable connector with the card connector, then push on the cable connector until it seats.

The end of the cable connector has a release button. To remove the connector, press the release button and pull the connector away from the card.

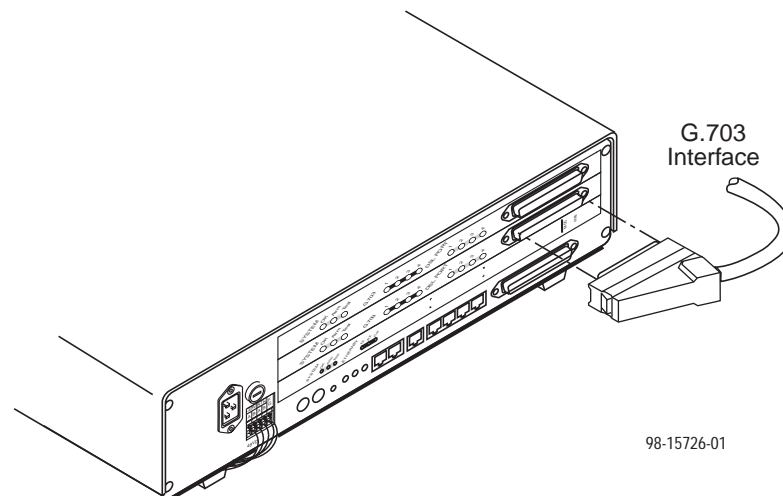

2. Feed the cable through the Cable Guide if it is in use. When all cables are installed, anchor them with cable ties to the rack, DSLAM, or Cable Guide.
3. Connect the four terminating connectors to your DTE.

Connecting to an MDF

You can connect the Hotwire DSLAM chassis containing the 8776 Termination Unit to an MDF or other demarcation point. Do not connect it to a POTS splitter.

► Procedure

To connect the Hotwire DSLAM chassis containing the 8776 Termination Unit to an MDF:

1. Plug the Telco 50-pin cable into the appropriate LINE port on the front panel of the chassis:

— On a Hotwire 8600 Series DSLAM chassis:

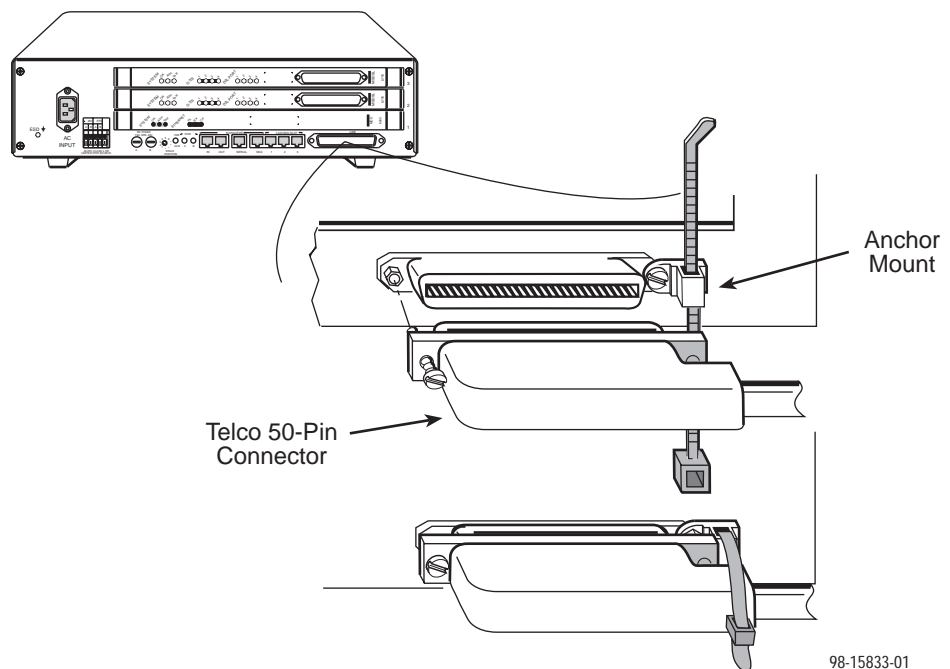

— On a Hotwire 8800 Series DSLAM chassis:

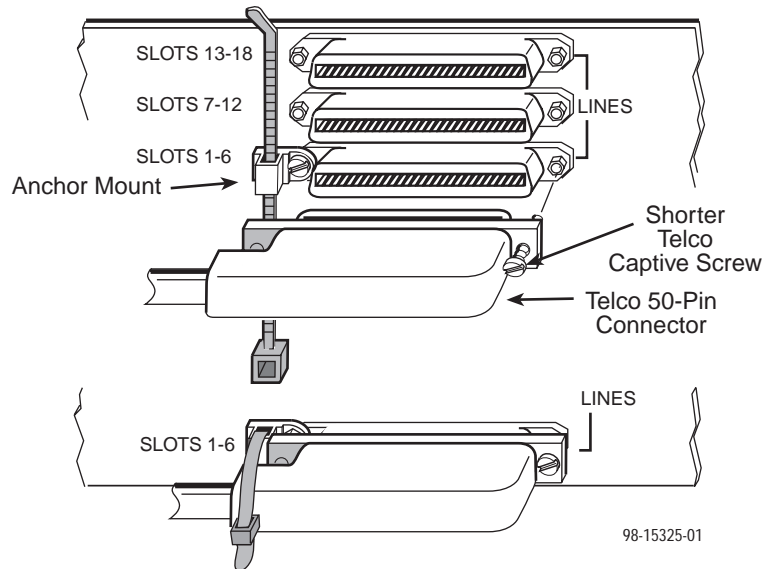

2. Replace the longer Telco cable captive screw with a shorter connector captive screw, which is provided with the Hotwire DSLAM chassis.
3. Insert a cable tie (provided with Hotwire DSLAM chassis) through the tie mount to hold the Telco 50-pin connector in place. If more than one Telco cable is being connected, span the two or three connectors.
4. Make sure the other end is connected to the appropriate MDF or demarcation point.

Refer to *Cables and Pin Assignments* in the User's Guide for pinouts.

NOTE:

If you are connecting the Telco 25-pair, 50-pin cable to an MDF, a converter may be necessary for terminating the other end of the cable on a punchdown block before cross-connecting to an MDF.

Model 8776 Termination Unit LEDs

The following table describes the meaning and states of the LEDs on the 8776 Termination Unit faceplate.

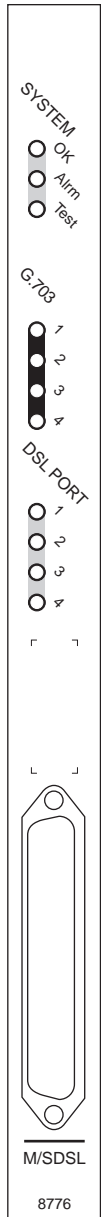

98-16041-01

Type	LED	LED is . . .	Indicating . . .
SYSTEM	OK	Green	Normal operation; termination unit functioning normally.
		Off	No power to termination unit, or failure has occurred.
	Alarm	Amber	Device failure, or Power-On Self-Test (POST) is not complete.
Off		No alarms.	
SYSTEM	Test	Amber	Loopback test or 511 test pattern in progress.
		Amber, flashing	POST in progress.
		Off	No tests currently active.
G.703	1, 2, 3, 4	Green	Recoverable signal present on the G.703 network.
		Amber	Remote Alarm Indication (RAI) present.
		Amber, flashing	An OOF condition exists.
		Off	The DSL LINK is down.
DSL PORT	1, 2, 3, 4	Green	DSL link is up.
		Amber	DSL training in progress.
		Amber, flashing	OOF condition.
		Off	DSL link is down.

Logging In to the Hotwire DSLAM

You can log in to the Hotwire DSLAM system using either a local VT100-compatible terminal or a remote Telnet connection. The Hotwire DSLAM system accepts only one login session at a time.

At the Operator Login screen, enter your login ID and password.

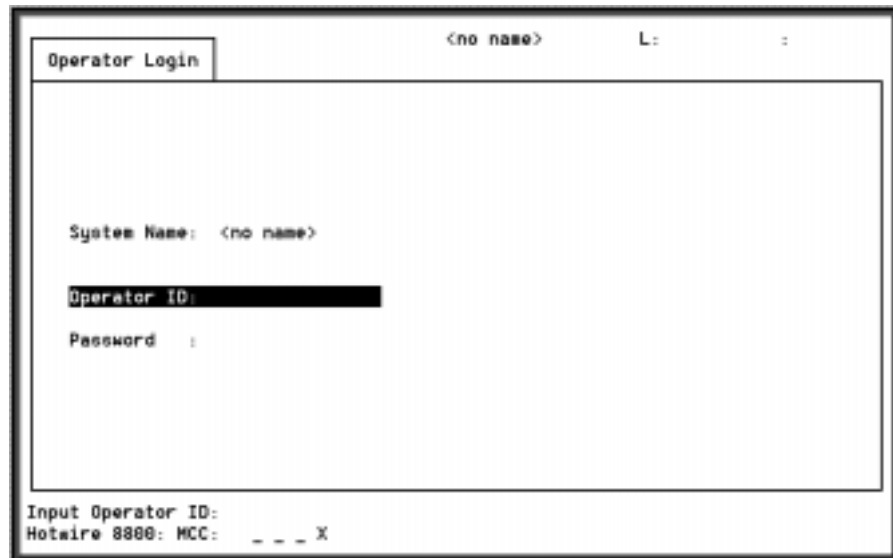

The screenshot shows a terminal window titled "Operator Login". At the top right, it displays "<no name> L: :". The main area contains the following text: "System Name: <no name>", "Operator ID:" followed by a blacked-out input field, and "Password :". At the bottom of the window, it says "Input Operator ID:" and "Hotwire 8888: MCC: _ _ _ X".

NOTE:

The login ID and password are case-sensitive; that is, the system recognizes both upper- and lowercase letters. For example, if you enter your user name and password information in upper case letters and your assigned user name and password are in upper- and lowercase letters, the system will not let you log in.

After entering your login ID and password, the system displays the Hotwire Chassis Main Menu.

Selecting the 8776 Card from the DSLAM

From the Hotwire Chassis Main Menu, select Card Selection to display the cards present in the chassis by type and slot number. The Card Selection screen also displays general and interface status for each card.

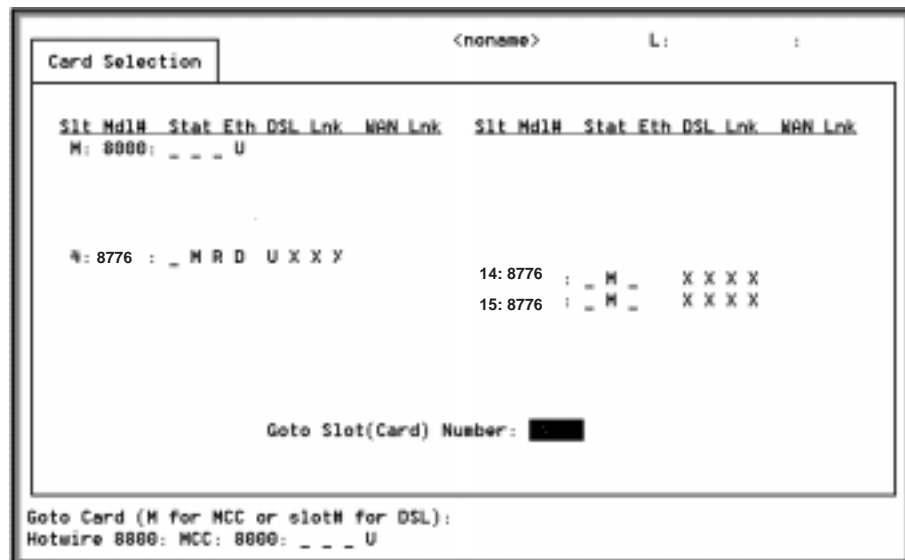

► Procedure

To access the 8776 Termination Unit Main Menu screen:

1. From the Hotwire Chassis Main Menu screen, select Card Selection. The Card Selection screen appears.
2. Verify that the card you want to access appears on the Card Selection screen. If the card does not appear, check the configuration of the MCC.
3. At the **Goto Card (M for MCC or slot# for DSL):** prompt, enter the number of the slot, then press Enter. For example, if you want to configure the card in Slot 4, enter **4**.

The 8776 Termination Unit Main Menu appears.

Entering Identity Information

After accessing your unit for the first time, use the Change Identity screen to determine SNMP administrative system information that will be displayed on the Identity screen of the Status branch. To access the Card Identity screen, follow this menu selection sequence:

Main Menu → Control → Change Identity

Network Configuration

The following illustration shows an E1 network application using an 8776 M/SDSL Termination Unit for access concentration in a central office (CO). A frame relay switch and a router are connected, through the termination unit, to partner units supporting an E1 host or router, and frame relay encapsulated or unframed data.

This figure also shows a central office-to-standalone configuration using a Hotwire 7975 M/SDSL standalone unit with an EIA-530A interface.

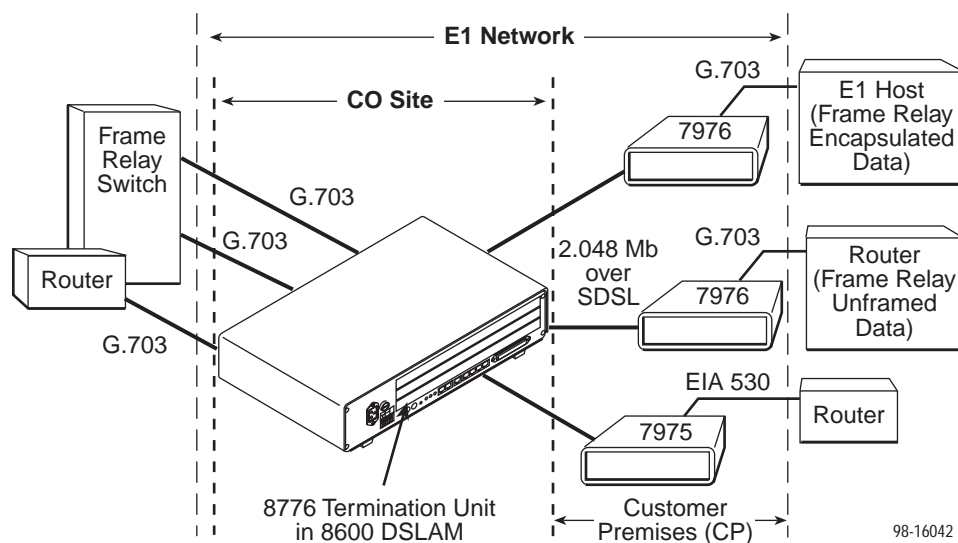

A DSLAM-to-DSLAM configuration requires that the 8776 Termination Unit at one end of the link be set to NTU mode. 8776 Termination Units default to LTU mode.

Configuring the 8776 Termination Unit

Configuration option settings determine how the 8776 Termination Unit operates. Use the Configuration branch of the 8776 Termination Unit menu to display or change configuration option settings.

If the factory default settings do not support your network's configuration, customize the configuration options for your application.

Accessing and Displaying Configuration Options

To display the configuration options, you must first load a configuration option set into the edit area.

To load a configuration option set into the configuration edit area, follow this menu selection sequence:

Main Menu → Configuration (Load Configuration From)

```
main/configuration                               Hotwire
Slot: 4                                         Model: 8776

                                LOAD CONFIGURATION FROM:

                                Current Configuration
                                Configuration Loader
                                Default Factory Configuration

-----
Ctrl-a to access these functions, ESC for previous menu      MainMenu  Exit
```

Make a selection by placing the cursor at your choice and pressing Enter.

If you select ...	Then ...
Current Configuration	The selected configuration option set is loaded and the Configuration Edit/Display menu screen appears.
Default Factory Configuration	The selected configuration option set is loaded and the Configuration Edit/Display menu screen appears.
Configuration Loader	The Configuration Loader screen is displayed allowing you to upload or download configurations from a TFTP server.

Configuration Edit/Display

The Configuration Edit/Display screen is displayed when the current, customer, or default configuration is loaded and allows groups of configuration options to be displayed. To access the Configuration Edit/Display screen, follow this menu selection sequence:

Main Menu → Configuration → Current Configuration

– or –

Main Menu → Configuration → Default Factory Configuration

```

main/config/edit                               Hotwire
Slot: 4                                       Model: 8776

                                CONFIGURATION EDIT/DISPLAY

                                Network
                                G.703
                                Copy Ports
                                System Options
                                Management and Communication

-----
Ctrl-a to access these functions, ESC for previous menu      MainMenu  Exit
Save
  
```

Select ...	To Access the ...	To Configure the ...
Network	Network Interface Options, Table 1	E1 SDSL network interface Ports 1–4.
G.703	G.703 Interface Options, Table 2	G.703 interface.
Copy Ports	Copy Ports Options, Table 3	E1 SDSL network and G.703 interface ports by copying options from port to port.
System Options	System Options, Table 4	General system options of the unit.
Management and Communication	<ul style="list-style-type: none"> ■ Telnet Session Options, Table 5 ■ General SNMP Management Options, Table 6 ■ SNMP NMS Security Options, Table 7 ■ SNMP Traps Options, Table 8 	Management support of the unit through SNMP and Telnet.

Table 1. Network Interface Options

Margin Threshold
Possible Settings: -5db, -4db, -3db, -2db, -1db, 0db, 1db, 2db, 3db, 4db, 5db, 6db, 7db, 8db, 9db, 10db Default Setting: 0db
Determines the level, expressed in decibels, at which a signal-to-noise margin condition is recognized.
Excessive Error Rate Threshold
Possible Settings: 1E-4, 1E-5, 1E-6, 1E-7, 1E-8, 1E-9 Default Setting: 1E-6
Determines the error rate at which an excessive error rate (EER) condition is recognized. The rate is the ratio of the number of CRC errors to the number of bits received in a certain period.
AutoRate
Possible Settings: Enable, Disable Default Setting: Disable
Specifies whether the DSL line will automatically train up to the best rate or if the line rate will be user selectable. <ul style="list-style-type: none">■ AutoRate is only available when the unit is configured as an LTU.
DSL Line Rate
Possible Settings: 400, 528, 784, 1040, 1552, 2064 Default Setting: 2064
Specifies the DSL line rate of the unit. <ul style="list-style-type: none">■ DSL Line Rate is only available when the unit is configured as an LTU and AutoRate is disabled (unit is in fixed rate).
Peer IP Address (LTU Only)
Possible Settings: 000.000.000.001 – 223.255.255.255, Clear Default Setting: 000.000.000.000
Specifies the peer IP address providing the remote management link on the DSL loop. The Peer IP Address is only available when the unit is configured as an LTU.
Circuit Identifier
Possible Settings: [ASCII Text], Clear Default Setting: [blank]
Uniquely identifies the circuit number of the transmission vendor's DSL line for troubleshooting purposes.

Table 2. G.703 Interface Options

Port Status
Possible Settings: Enable, Disable Default Setting: Enable
Determines whether the port can be configured and used.
Line Coding
Possible Settings: AMI, HDB3 Default Setting: HDB3
Specifies the line coding format to be used by the G.703 interface.
Line Framing (LTU Only)
Possible Settings: CRC4, noCRC4 Default Setting: noCRC4
Specifies the framing format to be used by the G.703 interface. <ul style="list-style-type: none">■ Line Framing is only available when the unit is configured as an LTU, AutoRate is disabled, and the DSL Line rate is 2064 kbps. Otherwise the noCRC4 framing format is used. The NTU is automatically configured to match the framing format used by the LTU.
Time Slot 16
Possible Settings: Signaling, Data Default Setting: Signaling
Specifies whether the G.703 interface is used for voice or data.
Send (AIS) on Network Failure
Possible Settings: Enable, Disable Default Setting: Enable
Specifies the action taken on the signal transmitted to the G.703 when a valid signal cannot be recovered from the network interface (LOS or OOF).
Primary Clock Source
Possible Settings: Internal, G.703 Default Setting: Internal
Determines the primary clock source for the 8776 Termination Unit. <ul style="list-style-type: none">■ Primary Clock Source is only available when the standalone unit is configured as an LTU.

Table 3. Copy Ports Options

From: Port <i>n</i>
Possible Settings: 1, 2, 3, 4 Default Setting: 1
Controls the source of the configuration options.
To: Port <i>y</i>
Possible Settings: 1, 2, 3, 4, All Default Setting: 2
Controls the target of the configuration options. NOTE: Peer IP Address and Circuit Identifier are <i>not</i> copied.

Table 4. System Options

DSL Mode
Possible Settings: LTU, NTU Default Setting: LTU
Controls whether the unit is configured as a control unit or tributary unit. NOTE: Changing this option will reset the card.
Test Timeout
Possible Settings: Enable, Disable Default Setting: Enable
Allows tests to end automatically. The feature should be enabled when the unit is remotely managed, so that control can be regained after a test is accidentally executed.
Test Duration (min)
Possible Settings: 1–120 Default Setting: 10
Number of minutes for a test to be active before automatically ending. ■ Test Duration (min) option appears when Test Timeout is enabled.
G.703 Line Termination
Possible Settings: 75 ohms, 120 ohms Default Setting: 120 ohms
Specifies the impedance of the G.703 interface

Table 5. Telnet Session Options

Telnet Session
Possible Settings: Enable, Disable Default Setting: Enable
Specifies if the 8776 Termination Unit will respond to a Telnet session request from a Telnet client on an interconnected IP network.
Telnet Login Required
Possible Settings: Enable, Disable Default Setting: Disable
Specifies whether a user ID and password are required to access to the ATI through a Telnet session. Login IDs are created with a password and access level.
Session Access Level
Possible Settings: Administrator, Operator Default Setting: Administrator
The Telnet session access level is interrelated with the access level of the Login ID.
Inactivity Timeout
Possible Settings: Enable, Disable Default Setting: Disable
Provides automatic logoff of a Telnet session.
Disconnect Time (Minutes)
Possible Settings: 1–60 Default Setting: 5
Number of minutes of inactivity before a Telnet session terminates automatically. Timeout is based on no keyboard activity. <ul style="list-style-type: none">■ Disconnect Time (minutes) option appears when Inactivity Timeout is enabled.

Table 6. General SNMP Management Options

SNMP Management
Possible Settings: Enable, Disable Default Setting: Disable
Enables or disables the SNMP management features.
Community Name 1
Possible Settings: ASCII text field, Public Default Text: Public
Identifies the name of the community allowed to access the unit's MIB. The community name must be supplied by an external SNMP manager when that manager attempts to access an object in the MIB.
Name 1 Access
Possible Settings: Read, Read/Write Default Setting: Read
Determines the access level for Community Name 1.
Community Name 2
Possible Settings: ASCII text field, Public Default Text: Public
Identifies the name of the second community allowed to access the unit's MIB. The community name must be supplied by an external SNMP manager when that manager attempts to access an object in the MIB.
Name 2 Access
Possible Settings: Read, Read/Write Default Setting: Read
Determines the access level for Community Name 2.

Table 7. SNMP NMS Security Options

NMS IP Validation
Possible Settings: Enable, Disable Default Setting: Disable
Specifies whether security checking is performed on the IP address of SNMP management systems attempting to access the node.
Number of Managers
Possible Settings: 1, 2, 3, 4, 5, 6, 7, 8, 9, 10 Default Setting: 1
Specifies the number of SNMP management systems that can send SNMP messages.
NMS <i>n</i> IP Address
Possible Settings: 000.000.000.000 – 223.255.255.255, Clear Default Setting: 000.000.000.000
Specifies the Internet Protocol address used to identify each SNMP manager.
Access Level
Possible Settings: Read, Read/Write Default Setting: Read
Determines the access level allowed for an authorized NMS when IP address validation is being performed.

Table 8. SNMP Traps Options

SNMP Traps
Possible Settings: Enable, Disable Default Setting: Disable
Controls the generation of SNMP trap messages. The options for addresses and types of traps are located in this table.
Number of Trap Managers
Possible Settings: 1, 2, 3, 4, 5 Default Setting: 1
Sets the number of SNMP management systems that will receive SNMP traps.
NMS <i>n</i> IP Address
Possible Settings: 000.000.000.000 – 223.255.255.255, Clear Default Setting: 000.000.000.000
Specifies the Internet Protocol address used to identify each SNMP trap manager.
NMS <i>n</i> Destination (NTU Only)
Possible Settings: IMC, DSL1, DSL2, DSL3, DSL4 Default Setting: IMC
Provides the network destination path of each trap manager.
General Traps
Possible Settings: Disable, Warm, AuthFail, Both Default Setting: Both
Determines which SNMP traps are sent to each trap manager.
Enterprise Specific Traps
Possible Settings: Enable, Disable Default Setting: Disable
Determines if SNMP traps are generated for enterprise-specific events.
Link Traps
Possible Settings: Disable, Up, Down, Both Default Setting: Both
Determines if SNMP traps are generated for link up and link down for one of the communication interfaces.
Link Trap Interfaces
Possible Settings: Network, G.703, All Default Setting: All
Determines if the SNMP <i>linkUp</i> , SNMP <i>linkDown</i> , and interface-related <i>enterpriseSpecific</i> traps are generated for the network DSL interface and/or G.703 interface (DTE).

Configuring AutoRate

The M/SDSL AutoRate function is controlled from the Network Interface Options screen and allows you to enable or disable AutoRate. The AutoRate option is only available if the unit is configured as an LTU. To access the Network Interface screen, follow this menu selection sequence:

NOTE:

AutoRate is designed to find the best rate possible for your DSL loop conditions. After the DSL loop is up, units should be configured to run in fixed rate.

Main Menu → Configuration → Network

```
main/config/network                               Hotwire
Slot 4                                           Model: 8776

                                NETWORK INTERFACE OPTIONS

Margin Threshold:                               -3db
Excessive Error Rate Threshold:                 1E-6
AutoRate                                         Disable
DSL Line Rate                                   528

Peer IP Address:                               111.255.255.000 Clear

Circuit Identifier: _____ Clear

-----
Ctrl-a to access these functions, ESC for previous menu   MainMenu Exit
Save
```

► Procedure

The AutoRate option is defaulted to Disable. To enable AutoRate:

1. Position the cursor in the AutoRate field and press the spacebar.
The AutoRate field toggles to Enable and the DSL Line Rate field displays.
2. Enter a DSL Line Rate and press Enter.
Your payload rate is set to a default value of 1984. Use Table 9, Fixed Rate Payload Rates and DSL Line Rates, to set your DSL Line Rate and Payload Rate according to whether you are configured for Voice (signaling) or Data.

Table 9 provides the maximum payload rates achievable for each DSL line rate and the number of time slots required to achieve that payload rate depending on whether you are using signaling (time slots 0 and 16) or data only (time slot 0).

Table 9. Fixed Rate Payload Rates and DSL Line Rates

DSL Line Rate (kbps)	Voice Mode (G.703 to G.703)		Data Mode (G.703 to G.703)		Data Mode (G.703 to EIA-530)	
	Maximum Payload Rate (kbps)	Time Slots	Maximum Payload Rate (kbps)	Time Slots	Maximum Payload Rate (kbps)	Time Slots
2064	1920	30	1984	31	1984	31
1552	1408	22	1472	23	1536	24
1040	896	14	960	15	1024	16
784	640	10	704	11	768	12
528	384	6	448	7	512	8
400	256	4	320	5	384	6

⚠ Important Safety Instructions

1. Read and follow all warning notices and instructions marked on the product or included in the manual.
2. Slots and openings in the cabinet are provided for ventilation. To ensure reliable operation of the product and to protect it from overheating, these slots and openings must not be blocked or covered.
3. Do not allow anything to rest on the power cord and do not locate the product where persons will walk on the power cord.
4. Do not attempt to install or service this product yourself, as opening or removing covers may expose you to dangerous high voltage points or other risks. Refer all installation and servicing to qualified service personnel.
5. General purpose cables are provided with this product. Special cables, which may be required by the regulatory inspection authority for the installation site, are the responsibility of the customer.
6. When installed in the final configuration, the product must comply with the applicable Safety Standards and regulatory requirements of the country in which it is installed. If necessary, consult with the appropriate regulatory agencies and inspection authorities to ensure compliance.
7. A rare phenomenon can create a voltage potential between the earth grounds of two or more buildings. If products installed in separate buildings are **interconnected**, the voltage potential may cause a hazardous condition. Consult a qualified electrical consultant to determine whether or not this phenomenon exists and, if necessary, implement corrective action prior to interconnecting the products.
8. In addition, if the equipment is to be used with telecommunications circuits, take the following precautions:
 - Never install telephone wiring during a lightning storm.
 - Never install telephone jacks in wet locations unless the jack is specifically designed for wet locations.
 - Never touch uninsulated telephone wires or terminals unless the telephone line has been disconnected at the network interface.
 - Use caution when installing or modifying telephone lines.
 - Avoid using a telephone (other than a cordless type) during an electrical storm. There may be a remote risk of electric shock from lightning.
 - Do not use the telephone to report a gas leak in the vicinity of the leak.

EMI Warnings

⚠ WARNING:

This equipment has been tested and found to comply with the limits for a Class A digital device, pursuant to Part 15 of the FCC rules. These limits are designed to provide reasonable protection against harmful interference when the equipment is operated in a commercial environment. This equipment generates, uses, and can radiate radio frequency energy and, if not installed and used in accordance with the instruction manual, may cause harmful interference to radio communications. Operation of this equipment in a residential area is likely to cause harmful interference in which case the user will be required to correct the interference at his own expense.

The authority to operate this equipment is conditioned by the requirements that no modifications will be made to the equipment unless the changes or modifications are expressly approved by Paradyne Corporation.

⚠ WARNING:

To Users of Digital Apparatus in Canada:

This Class A digital apparatus meets all requirements of the Canadian interference-causing equipment regulations.

Cet appareil numérique de la classe A respecte toutes les exigences du règlement sur le matériel brouilleur du Canada.

Warranty, Sales, Service, and Training Information

Contact your local sales representative, service representative, or distributor directly for any help needed. For additional information concerning warranty, sales, service, repair, installation, documentation, training, distributor locations, or Paradyne worldwide office locations, use one of the following methods:

- **Internet:** Visit the Paradyne World Wide Web site at www.paradyne.com. (Be sure to register your warranty there. Select *Service & Support* → *Warranty Registration*.)
- **Telephone:** Call our automated system to receive current information by fax or to speak with a company representative.
 - Within the U.S.A., call 1-800-870-2221
 - Outside the U.S.A., call 1-727-530-2340

Asynchronous Terminal Interface Menu

The following illustration shows the paths to the different ATI screens.

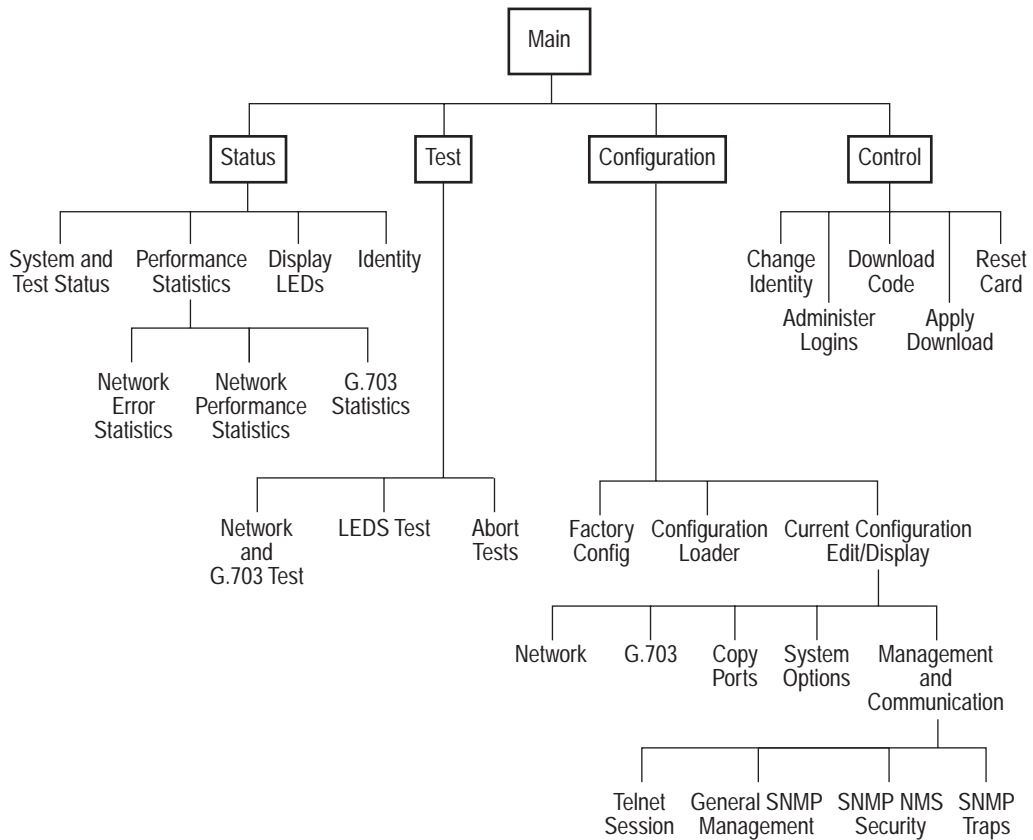

99-16044-01

Document Feedback

We welcome your comments and suggestions about this document. Please mail them to Technical Publications, Paradyne Corporation, 8545 126th Ave. N., Largo, FL 33773, or send e-mail to userdoc@paradyne.com. Include the number and title of this document in your correspondence. Please include your name and phone number if you are willing to provide additional clarification.



8776-A2-GZ40-20