

**ATM Line Cards**  
**Models 8955, 8965, 8968,**  
**8975, and 8985**  
**User's Guide**

Document No. 8900-A2-GB20-40

March 2005

---

**Copyright 2005 Paradyne Corporation.  
All rights reserved.  
Printed in U.S.A.**

## **Notice**

This publication is protected by federal copyright law. No part of this publication may be copied or distributed, transmitted, transcribed, stored in a retrieval system, or translated into any human or computer language in any form or by any means, electronic, mechanical, magnetic, manual or otherwise, or disclosed to third parties without the express written permission of Paradyne Corporation, 8545 126th Ave. N., Largo, FL 33773.

Paradyne Corporation makes no representation or warranties with respect to the contents hereof and specifically disclaims any implied warranties of merchantability or fitness for a particular purpose. Further, Paradyne Corporation reserves the right to revise this publication and to make changes from time to time in the contents hereof without obligation of Paradyne Corporation to notify any person of such revision or changes.

Changes and enhancements to the product and to the information herein will be documented and issued as a new release to this manual.

## **Warranty, Sales, Service, and Training Information**

Contact your local sales representative, service representative, or distributor directly for any help needed. For additional information concerning warranty, sales, service, repair, installation, documentation, training, distributor locations, or Paradyne worldwide office locations, use one of the following methods:

- **Internet:** Visit the Paradyne World Wide Web site at [www.paradyne.com](http://www.paradyne.com). (Be sure to register your warranty at [www.paradyne.com/warranty](http://www.paradyne.com/warranty).)
- **Telephone:** Call our automated system to receive current information by fax or to speak with a company representative.
  - Within the U.S.A., call 1-800-870-2221
  - Outside the U.S.A., call 1-727-530-2340

## **Document Feedback**

We welcome your comments and suggestions about this document. Please mail them to Technical Publications, Paradyne Corporation, 8545 126th Ave. N., Largo, FL 33773, or send e-mail to [userdoc@paradyne.com](mailto:userdoc@paradyne.com). Include the number and title of this document in your correspondence. Please include your name and phone number if you are willing to provide additional clarification.

## **Trademarks**

Acculink, ADSL/R, Bitstorm, Comsphere, DSL the Easy Way, ETC, Etherloop, FrameSaver, GranDSLAM, GrandVIEW, Hotwire, the Hotwire logo, iMarc, Jetstream, MVL, NextEDGE, Net to Net Technologies, OpenLane, Paradyne, the Paradyne logo, Paradyne Credit Corp., the Paradyne Credit Corp. logo, Performance Wizard, ReachDSL, StormPort, TruePut are registered trademarks of Paradyne Corporation.

Connect to Success, Hotwire Connected, JetFusion, JetVision, MicroBurst, PacketSurfer, Quick Channel, Reverse Gateway, Spectrum Manager, and StormTracker are trademarks of Paradyne Corporation.

All other products or services mentioned herein are the trademarks, service marks, registered trademarks, or registered service marks of their respective owners.

## **Regulatory and Safety Information**

Refer to the appropriate Broadband Loop Carrier (BLC) installation guide for all regulatory notices and safety information.

---

# Contents

---

## About This Guide

■ Document Purpose and Intended Audience .....	iii
■ Document Summary .....	iii
■ Product-Related Documents .....	iv

## 1 About the ATM Line Cards

■ ATM Line Cards .....	1-1
■ ATM Line Card Features .....	1-2
ATM Features .....	1-2
Endpoint Support Features .....	1-2
■ Sample Network Configurations .....	1-3
■ SNMP Management Capabilities .....	1-4
Management Information Base (MIB) Support .....	1-4
SNMP Trap Support .....	1-4

## 2 Accessing the SCP Card Web Interface

■ Introduction .....	2-1
■ Logging Into the Web Interface .....	2-1
■ Help Button .....	2-2
■ Ending a Session .....	2-2

## 3 Configuration Using the Web Interface

■ Overview .....	3-1
■ Configuring Spectrum Management .....	3-1
■ Configuring ReachDSL Ports (8955 and 8975) .....	3-2
■ Configuring ADSL Ports (8965, 8968) .....	3-3
■ Configuring SHDSL Ports (8985) .....	3-5
■ Configuring Line Profiles (8955, 8965, 8975, 8968) .....	3-6
■ Creating Line Profiles for Ports (8985) .....	3-7
■ Configuring Alarm Threshold Profiles (8955, 8965, 8968, 8975) .....	3-8
■ Creating Alarm Threshold Profiles for Model 8985 .....	3-10
■ Configuring Cross Connections .....	3-12
Default Mappings .....	3-12

	Adding a Port-to-Port Cross Connection .....	3-12
	Adding a Slot-to-Slot Cross Connection .....	3-14
■	Configuring ATM Ports .....	3-16
■	Configuring Traffic Profiles .....	3-17
<b>4</b>	<b>Monitoring</b>	
■	What to Monitor .....	4-1
■	Front Panel LEDs (Models 8955, 8965, 8975, and 8985) .....	4-3
■	Front Panel LEDs (Model 8968).....	4-4
<b>5</b>	<b>Diagnostics</b>	
■	Overview .....	5-1
■	Lamp Test .....	5-1
■	Loopback Test (Model 8985 Only).....	5-2
<b>6</b>	<b>Maintenance Procedures</b>	
■	Overview .....	6-1
■	Uploading and Downloading a Configuration.....	6-2
	Resetting the Configuration to Default Settings.....	6-3
	Resetting the Configuration to Downloaded Settings .....	6-3
■	Downloading and Switching Firmware .....	6-4
	Downloading Firmware .....	6-4
	Switching Firmware .....	6-5
■	Restarting the Line Card .....	6-5
<b>A</b>	<b>Connector Pin Assignments</b>	
■	8620 and 8820 Telco Connector Pinouts.....	A-1
■	Model 8968 Line Card Telco Connector Pinouts .....	A-2

**B Technical Specifications**

**Index**

---

# About This Guide

---

## Document Purpose and Intended Audience

This guide contains information needed to configure and operate the Models 8955-B1, 8965-B2, 8968-B1, 8975-B1, and 8985-B2 ATM line cards, and is intended for installers and operators. Basic installation information can be found in the *ATM Line Cards, Models 8955, 8965, 8968, 8975, and 8985, Installation Instructions*.

## Document Summary

Section	Description
<a href="#">Chapter 1, <i>About the ATM Line Cards</i></a>	Describes the cards' features and capabilities.
<a href="#">Chapter 2, <i>Accessing the SCP Card Web Interface</i></a>	Provides instructions for accessing the user interface.
<a href="#">Chapter 3, <i>Configuration Using the Web Interface</i></a>	Provides instructions for configuring the line cards.
<a href="#">Chapter 4, <i>Monitoring</i></a>	Describes how to locate information about a line card and its status.
<a href="#">Chapter 5, <i>Diagnostics</i></a>	Provides instructions for running a lamp test and loopback test.
<a href="#">Chapter 6, <i>Maintenance Procedures</i></a>	Provides instructions for uploading or downloading a configuration, downloading firmware, and resetting the card.
<a href="#">Appendix A, <i>Connector Pin Assignments</i></a>	Lists the pin assignments for the Broadband Loop Carrier (BLC) Telco connectors.
<a href="#">Appendix B, <i>Technical Specifications</i></a>	Contains physical and regulatory specifications, and power consumption values.
<a href="#">Index</a>	Lists key terms, acronyms, concepts, and sections in alphabetical order.

A master glossary of terms and acronyms used in Paradyne documents is available on the World Wide Web at [www.paradyne.com](http://www.paradyne.com). Select *Support* → *Technical Manuals* → [Technical Glossary](#).

## Product-Related Documents

Complete documentation for this product is available online at [www.paradyne.com](http://www.paradyne.com). Select *Support* → [Technical Manuals](#).

Document Number	Document Title
<a href="#">6381-A2-GN10</a>	<i>Hotwire ReachDSL Modem, Model 6381 with Inline Phone Filter, Installation Instructions</i>
<a href="#">6390-A2-GK40</a>	<i>Hotwire ReachDSL Modem, Model 6390 with Inline Phone Filter, Installation and Operation Supplement</i>
<a href="#">6390-A2-GN10</a>	<i>Hotwire ReachDSL Modem, Model 6390 with Inline Phone Filter, Installation Instructions</i>
<a href="#">7890-A2-GB22</a>	<i>GrandVIEW EMS User's Guide</i>
<a href="#">8000-A2-GB30</a>	<i>8620 and 8820 Broadband Loop Carrier SNMP Reference</i>
<a href="#">8400-A2-GB20</a>	<i>Shelf Concentration and Processing (SCP) Card with ATM Uplink User's Guide</i>
<a href="#">8400-A2-GB21</a>	<i>Shelf Concentration and Processing (SCP) Card with IP Uplink User's Guide</i>
<a href="#">8400-A3-GB21</a>	<i>8620 and 8820 Broadband Loop Carrier TL1 Interface Reference</i>
<a href="#">8400-A3-GB22</a>	<i>8620 and 8820 Broadband Loop Carrier Command Line Interface Reference</i>
<a href="#">8620-A2-GN20</a>	<i>8620 Broadband Loop Carrier Installation Guide</i>
<a href="#">8820-A2-GN20</a>	<i>8820 Broadband Loop Carrier Installation Guide</i>
<a href="#">8900-A2-GZ40</a>	<i>ATM Line Cards, Models 8955, 8965, 8968, 8975, and 8985, Installation Instructions</i>

To order a paper copy of a Paradyne document, or to speak with a sales representative, please call 1-727-530-2000.

---

# About the ATM Line Cards

# 1

---

## ATM Line Cards

The 8955, 8965, 8968, 8975, and 8985 Asynchronous Transfer Mode (ATM) Line Cards are circuit boards mounted in an 8620 or 8820 Broadband Loop Carrier (BLC) and used to transport ATM cells at high speeds over a single twisted-pair connection or, optionally, two twisted-pair connections (8985 only).

- Model 8955 supports ReachDSL. It automatically adjusts to the highest rate the loop can support, from 32 to 2176 kbps. It has 24 ports.
- Models 8965 and 8968 support Asymmetric Digital Subscriber Line (ADSL). They can be set to adapt to the line conditions at startup, or set to the following fixed rates depending on line code:
  - G.lite: 64 to 3008 kbps downstream and 32 to 512 kbps upstream.
  - G.dmt, ANSI T1.413, ADSL2, and ADSL2+: 32 to 8000 kbps downstream and 32 to 832 kbps upstream.
  - ADSL2: 32 to 16000 kbps downstream and 32 to 1056 kbps upstream.
  - ADSL2+: 32 to 29000 kbps downstream and 32 to 2200 kbps upstream.

The Model 8965 has 24 ports and the Model 8968 has 48 ports.

- Model 8975 supports ReachDSL+, providing ADSL or ReachDSL 2.2 on a port-by-port basis depending on the capabilities of the line and endpoint.
- Model 8985 supports Single-pair High-speed Digital Subscriber Line (SHDSL). It can be set to adapt to the line conditions at startup, or set to a fixed line rate from 192 to 2304 kbps (or 384 to 4608 kbps with two wire pairs). It has 24 ports.

The 8955, 8965, 8968, 8975, and 8985 line cards are configured and managed using the Shelf Concentration and Processing (SCP) card.

Part of Paradyne's Hotwire Connected™ program, the cards interoperate with third-party DSL endpoints providing end users with the ability to select the best equipment to fit their application. The line cards also integrate support for multiple DSL services on a single card.

## ATM Line Card Features

The ATM Line Cards have these standard features:

- **Alarm indication.** Activates front panel LEDs.
- **Diagnostics.** Provides lamp test and SHDSL line loopback (8985).
- **Device and test monitoring.** Provides the capability of tracking and evaluating the unit's operation, including health and status, and error-rate monitoring.
- **Software upgrade.** Supports software upgrades using FTP.

## ATM Features

The cards' ATM features include:

- **Classes of service.** Supports traffic management service categories necessary to support voice and data applications:
  - CBR
  - rt-VBR
  - nrt-VBR
  - UBR (only class of service supported for the Model 8955)
- **Auto configuration.** Two Virtual Channel Connections (VCCs) per port are automatically configured, providing data and voice services.
- **Multiple virtual circuits.** Up to 250 additional VCCs can be configured by the user and assigned among the DSL ports.
- **ATM statistics.** Maintains statistics for:
  - Total cells received
  - Total cells transmitted
  - Total cells dropped
  - Loss of cell delineation events
  - Cells with uncorrectable HEC

## Endpoint Support Features

The cards' endpoint support features include:

- **Third-party endpoint support.** Models 8965, 8968, 8975, and 8985 line cards support third-party endpoints through the Hotwire Connected program, including Integrated Access Devices (IADs) and data-only endpoints from numerous industry-leading vendors. The Model 8985 card supports third-party endpoints using the ITU SHDSL standard. A list of Paradyne's SHDSL partners is available on the World Wide Web at [www.paradyne.com](http://www.paradyne.com). Select *Company* → *Partners* → [Hotwire Connected Interoperability Program](#).

- **Model 6381 and 6390 Modem support.** Models 8955, 8965, 8975, and 8968 line cards support the Model 6381 Modem. The Model 8955 line card also supports the discontinued Model 6390 Modem.
- **Model 8300 Modem support.** The Model 8985 line card supports the Model 8300 Modem.
- **Automatic rate adaptation.** The card and the endpoint negotiate the best rate, limited if desired by the user, through automatic rate adaptation.

## Sample Network Configurations

Figure 1-1 shows the ATM Line Card used to carry voice over DSL.

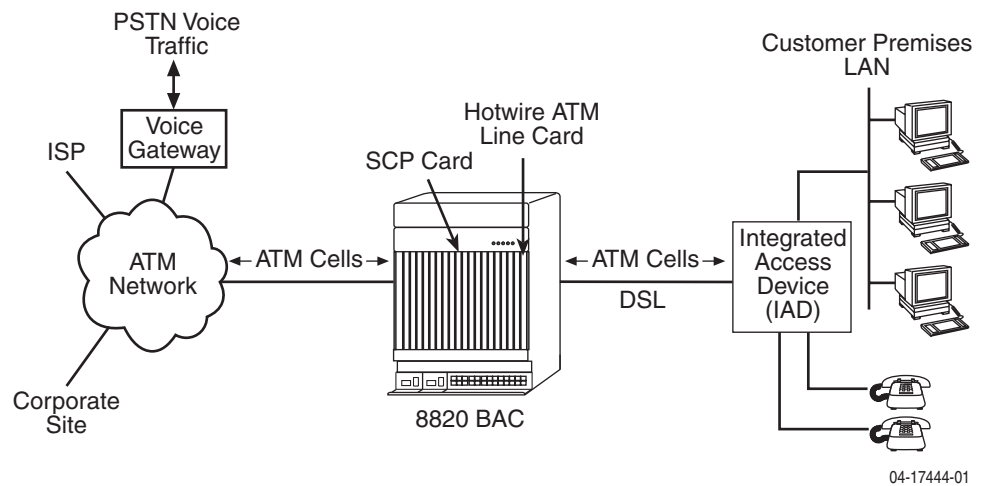

Figure 1-1. Endpoint with Voice Interfaces

Figure 1-2 shows a configuration in which the endpoints include a router to provide data encapsulation.

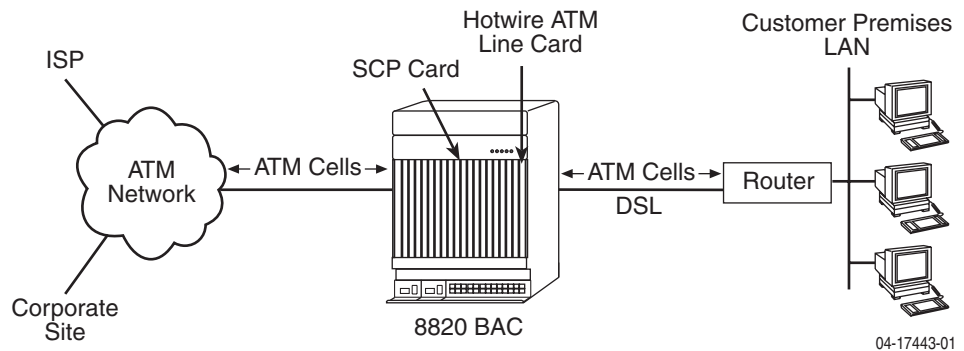

Figure 1-2. Router Endpoint

## SNMP Management Capabilities

The ATM Line Cards support SNMP Version 1, and can be managed by Paradyne's GrandVIEW<sup>®</sup> or any industry-standard SNMP manager.

### Management Information Base (MIB) Support

For a detailed description of supported MIBs, visit Paradyne's Web site at [www.paradyne.com](http://www.paradyne.com). The following MIBs are supported:

- ATM Forum SNMP M4 Network Element View (af-nm-0095.001)
- Definitions of Managed Objects for the ADSL Lines (RFC 2662)
- Definitions of Managed Objects for ATM Management (RFC 2515)
- Definitions of Managed Objects for HDSL2 and SHDSL Lines (draft-ietf-adslmib-hdsl2-10.txt)
- Definitions of Textual Conventions and OBJECT-IDENTITIES for ATM Management (RFC 2514)
- Evolution of MIB II Interfaces (RFC 2863)
- ADSL Extension MIB (Models 8965, 8975, and 8968) (draft-ietf-adslmib-adslext.txt)
- SHDSL MIB (Model 8985 only) (draft-ietf-adslmib-hdsl2.txt)
- Entity MIB Using SMIv2 (RFC 2037)
- MIB II and the Interfaces Group MIB (RFC 1213, RFC 2233)
- Paradyne enterprise MIBs for:
  - xDSL Interface
  - SLE Device Control
  - SLE Device Health and Status
  - MaxVciVpi-MIB Table
  - IF-MIB Table
  - ATM VPL Statistics Table

### SNMP Trap Support

The ATM Line Cards support SNMP traps as shown in the *8620 and 8820 Broadband Loop Carrier SNMP Reference*.

---

# Accessing the SCP Card Web Interface

# 2

---

## Introduction

The ATM line cards can be configured and monitored using:

- The SCP card's Command Line Interface (see the [8620 and 8820 Broadband Loop Carrier Command Line Interface Reference](#)) or TL1 interface (see the [8620 and 8820 Broadband Loop Carrier TL1 Interface Reference](#))
- GrandVIEW EMS 4.1 or above (see the [GrandVIEW EMS User's Guide](#))
- SNMP using another EMS (see the [8620 and 8820 Broadband Loop Carrier SNMP Reference](#))
- The web interface of the Shelf Concentration and Processing (SCP) card.

## Logging Into the Web Interface

To access the web interface:

### ► Procedure

1. Open your web browser. (Internet Explorer Version 6 or above is recommended.)
2. Type http:// and the IP address of the SCP card into the Address field of your browser window. For example:



The default address is 10.10.10.10.

3. A login window appears. Enter the User ID and Password, and click on OK. The web interface screen appears. The web interface screens consist of a header, a menu frame, and a content frame.

4. Click on the Configuration menu tab. The configuration screens available in the contents frame depend on the types of line cards and type of SCP card installed in the chassis. The Configuration - SHDSL Port screen is displayed here.

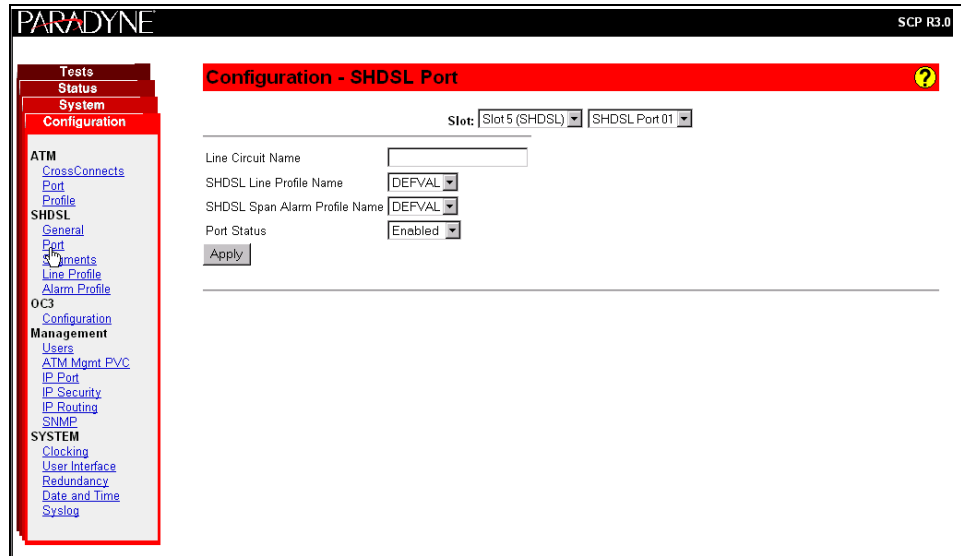

All main screens of the web interface can be reached by clicking on hyperlinks in the four menus:

- **Configuration** – Configure the system and interfaces
- **Status** – Display statistics, status, performance information, and contents of memory
- **System** – Display system information, download firmware, back up configurations, and reset the SCP card
- **Tests** – Start and stop tests

## Help Button

For more information about any screen, click on the  Help button on the screen. Help is displayed in a new window.

## Ending a Session

To end a session, close your web browser. This prevents an unauthorized user from accessing the system using your user name and password.

---

# Configuration Using the Web Interface

# 3

---

## Overview

This chapter provides instructions on how to configure the ATM line cards using the SCP card's web interface.

<b>If you would like to configure the card using . . .</b>	<b>See the . . .</b>
The BLC's TL1 Interface (when an SCP card with an ATM uplink is used)	<a href="#">8620 and 8820 Broadband Loop Carrier TL1 Interface Reference</a>
The BLC's router-like command line interface (when an SCP card with an IP uplink is used)	<a href="#">8620 and 8820 Broadband Loop Carrier Command Line Interface Reference</a>
GrandVIEW EMS 4.3 or above	<a href="#">GrandVIEW EMS User's Guide</a>
SNMP using another EMS	<a href="#">8620 and 8820 Broadband Loop Carrier SNMP Reference</a>

## Configuring Spectrum Management

Use the Configuration - DSL General screen to enable and disable Spectrum Management. When Spectrum Management is enabled, the maximum transmit speeds and maximum transmit power are limited to meet local spectrum management guidelines.

### ► Procedure

To enable or disable Spectrum Management:

1. Select Disable or Enable from the drop-down list.
2. For the 8985 line card, additionally select the Spectrum Management Region:
  - **ANSI T1417** – To select American National Standards Institute T1.417 definitions
  - **ANFP ND 1602** – To select Access Network Frequency Plan ND1602 definitions
3. Click on Apply.

## Configuring ReachDSL Ports (8955 and 8975)

Use the Configuration - DSL Port screen to set parameters for a DSL port on the Model 8955 ReachDSL or Model 8975 ReachDSL+ line card.

### ► Procedure

To configure a ReachDSL port:

1. Select a Port from the drop-down list and click on Select. Current values for the port are displayed.
2. Enter or select the following fields:

Field	Description
Line Circuit Name	Enter a name from 1 to 255 characters long to indicate to whom the port is assigned. The following values are reserved and cannot be used: AVAILABLE (port is not assigned), and FAULTY (port is faulty and can not be assigned).
Line Type	For the Model 8975 ReachDSL+ card, specify the line type: <ul style="list-style-type: none"> <li>■ ADSL – The port supports only ADSL</li> <li>■ ReachDSL – The port supports only ReachDSL</li> <li>■ Dual Mode – The port supports both ADSL and ReachDSL</li> </ul> This option does not appear for the Model 8955 line card.
Line Code	For the Model 8975 ReachDSL+ card, select the ADSL type supported: <ul style="list-style-type: none"> <li>■ MultiMode - The port uses the line code of its partner modem</li> <li>■ ANSI T1.413 - The port uses DMT modulation</li> <li>■ ITU G.dmt Annex A - The port uses G.992.1 Annex A modulation</li> <li>■ ITU G.dmt Annex B - The port uses G.992.1 Annex B modulation</li> <li>■ ITU G.lite - The port uses G.992.2 modulation</li> </ul> The Line Code parameter has no effect on a Model 8955 ReachDSL card.
DSL Line Profile Name	Enter the name of a DSL line profile to set rates for the port.
DSL Alarm Profile Name	Enter the name of a DSL alarm profile to set alarm thresholds for the port.

Field	Description
Max Tx Power	Specify the maximum transmit power setting for the ATU-C. The allowable Maximum Transmit Power range may be limited according to local spectrum management guidelines. The actual transmit power level will be based upon the symbol rate selected to maximize the transmit data rate and may be lower than the Maximum Transmit Power level configured.
Far End Max Tx Power	Specify the maximum transmit power setting for the ATU-R. The allowable Maximum Transmit Power range may be limited according to local spectrum management guidelines. The actual transmit power level will be based upon the symbol rate selected to maximize the transmit data rate and may be lower than the Maximum Transmit Power level configured.
Port Status	Select Enabled, Disabled, or Reset from the drop-down list to determine the status of the port.

3. Click on Apply.

## Configuring ADSL Ports (8965, 8968)

Use the Configuration - DSL Port screen to set parameters for an ADSL port on the 8965 or 8968 line card.

### ► Procedure

To configure an ADSL port:

1. Select a Port from the drop-down list and click on Select. Current values for the port are displayed.
2. Enter or select the following fields:

Field	Description
Line Circuit Name	Enter a name from 1 to 255 characters long to indicate to whom the port is assigned. The following values are reserved and cannot be used: AVAILABLE (port is not assigned), and FAULTY (port is faulty and can not be assigned).

Field	Description
Line Code	<p>Select a line code:</p> <ul style="list-style-type: none"> <li>■ MultiMode - The port uses the line code of its partner modem</li> <li>■ ANSI T1.413 - The port uses DMT modulation</li> <li>■ ITU G.dmt Annex A - The port uses G.992.1 Annex A modulation</li> <li>■ ITU G.dmt Annex B - The port uses G.992.1 Annex B modulation</li> <li>■ ITU G.lite - The port uses G.992.2 modulation</li> <li>■ ADSL2 Annex A - The port uses G.992.3 Annex A modulation</li> <li>■ ADSL2+ Annex A - The port uses G.992.5 Annex A modulation</li> </ul>
DSL Line Profile Name	Enter the name of a DSL line profile to set rates for the port.
DSL Alarm Profile Name	Enter the name of a DSL alarm profile to set alarm thresholds for the port.
ADSL2 PSD Profile Name	Select a PSD profile from the drop-down list.
ADSL2+ PSD Profile Name	Select a PSD profile from the drop-down list.
Power Management	<p>Specify whether power management is supported on this port:</p> <ul style="list-style-type: none"> <li>■ Enabled - Power management is enabled</li> <li>■ Disabled - Power management is disabled</li> </ul> <p>Power management refers to the following modes, defined in the ADSL2 specification:</p> <ul style="list-style-type: none"> <li>■ L2 low power: Power consumption is reduced at the local unit when there is no traffic. Entry to and exit from L2 low power mode happens so quickly that it is undetectable by the user.</li> <li>■ L3 low power: The port enters sleep mode during extended periods of inactivity, saving power at both the local and remote units.</li> </ul>
Power Management State Enabling	<p>Select the line states that the port may autonomously switch to on this line:</p> <ul style="list-style-type: none"> <li>■ Idle – L3 low-power mode</li> <li>■ Low Power – L2 low power mode</li> <li>■ Both – Both L2 and L3 low power modes</li> <li>■ None – Power management is disabled</li> </ul>
L0 Time	Specify the minimum number of seconds allowed between an exit from the low power (L2) state and the next entry into the low power state.

Field	Description
L2 Time	Specify the minimum number of seconds allowed between: <ul style="list-style-type: none"> <li>■ An entry into the low power (L2) state and the first power trim in the low power state</li> <li>■ Two consecutive power trims in the low power state</li> </ul>
Port Status	Select Enabled, Disabled, or Reset from the drop-down list to determine the status of the port.

3. Click on Apply.

## Configuring SHDSL Ports (8985)

Use the Configuration - SHDSL Port screen to set parameters for a DSL port on the 8985 line card.

### ► Procedure

To configure a DSL port:

1. Select a Port from the drop-down list and click on Select. Current values for the port are displayed.
2. Enter or select the following fields:

Field	Description
Line Circuit Name	Enter a name from 1 to 255 characters long to indicate to whom the port is assigned. The following values are reserved and cannot be used: AVAILABLE (port is not assigned), and FAULTY (port is faulty and can not be assigned).
SHDSL Line Profile Name	Enter the name of a DSL line profile to set rates for the port.
SHDSL Alarm Profile Name	Enter the name of a DSL alarm profile to set alarm thresholds for the port.
Equivalent Working Length	Specify the estimated length of the line. The length is used to limit transmit rates according to local spectrum management guidelines.
Port Status	Select Enabled, Disabled, or Reset from the drop-down list to determine the status of the port.

3. Click on Apply.

## Configuring Line Profiles (8955, 8965, 8975, 8968)

Use the Configuration - Line Profiles screens to define line profiles to be assigned to ports.

To create a line profile for ReachDSL and ADSL ports:

1. Click on Create New Profile. The ADSL Profile Create screen appears.
2. Enter or select the following fields:

Field	Description
Profile Name	Specify a name for this line profile.
Latency	Select the channel the following rates are effective for: Fast or Interleaved.  For ADSL, S=1/2 encoding is not supported when Latency is set to Fast. For ADSL2, S=1/2 is supported in both modes.
Rate Adaptive Mode	Select a rate adaptive mode: <ul style="list-style-type: none"> <li>■ Manual - Manually selected at startup</li> <li>■ Init - Automatically selected at startup</li> <li>■ Dynamic - Automatically selected at run time</li> </ul>
<i>Downstream / Near End Profile</i>	
Max Rate (kbps)	Enter a maximum rate from 0 to 65535.
Min Rate (kbps)	Enter a minimum rate from 0 to 65535.
Max Interleave Delay	Select the maximum delay allowed for the interleaved channel, in milliseconds.
Max Noise Margin	Select the maximum additional noise margin.
Min Noise Margin	Select the minimum noise margin.
Target Noise Margin	Select a target noise margin.
<i>Upstream / Far End Profile</i>	
Max Rate (kbps)	Enter a maximum rate from 0 to 65535.
Min Rate (kbps)	Enter a minimum rate from 0 to 65535.
Max Delay	Select the maximum delay allowed for the interleaved channel, in milliseconds: 1, 4, or 16.  To obtain the fastest rate downstream for ADSL (not ADSL2) endpoints that support S=1/2 encoding, set Latency to Interleaved and Max Delay to 1 ms.
Max Noise Margin	Select the maximum additional noise margin.
Min Noise Margin	Select the minimum noise margin.
Target Noise Margin	Select a target noise margin.

3. Click on Apply.

## Creating Line Profiles for Ports (8985)

### ► Procedure

To create a line profile for SHDSL ports:

1. Click on Create New Profile. The SHDSL Profile Create screen appears.
2. Enter or select the following fields:

Field	Description
Profile Name	Specify a name for this line profile.
Max Rate	Enter a maximum rate from 192 to 2304 kbps.
Min Rate	Enter a minimum rate from 192 to 2304 kbps.
Mode	Select the regional setting supported, as specified by ITU-T G.991.2: <ul style="list-style-type: none"> <li>■ Annex A</li> <li>■ Annex B</li> <li>■ Both</li> </ul>
Remote Management	Select Enable or Disable from the drop-down list to determine whether remote management is supported for the network element this profile is assigned to.
Reference Clock	Select the timing source from the drop-down list: <ul style="list-style-type: none"> <li>■ System – Clocking is provided by the backplane. (The backplane clock is configured on the Configuration - System - Clocking screen.)</li> <li>■ Local – Clocking is provided by an onboard oscillator.</li> </ul>
Target Margin	Enter a target noise margin from 2–15 dBm, or None.
Interface	Select an interface from the drop-down list: <ul style="list-style-type: none"> <li>■ Wire Pair 1 – The profile applies to Wire Pair 1.</li> <li>■ Wire Pair 2 – The profile applies to Wire Pair 2.</li> </ul> Select Wire Pair 1 if this profile is to be used for ports that use only one wire pair.

3. Click on Apply.

## Configuring Alarm Threshold Profiles (8955, 8965, 8968, 8975)

Use the Configuration - Alarm Threshold Profiles screen to define sets of alarm thresholds that you can apply to DSL ports.

To create an alarm threshold profile for a ReachDSL or ADSL line card:

1. Click on Create New Profile. The Alarm Threshold Profile Create screen appears.
2. Enter or select the following fields:

Field	Description
Profile Name	Specify a name for this alarm profile.
<i>Downstream / Near End Alarm Profile</i>	
Loss of Frame Seconds	SNMP trap and TL1 autonomous message are sent if the number of LOFS events in a 15-minute interval meets or exceeds the selected value (0–900 seconds, where 0 disables the messages).
Loss of Signal Seconds	SNMP trap and TL1 autonomous messages are sent if the number of LOS events in a 15-minute interval meets or exceeds the selected value (0–900 seconds, where 0 disables the messages).
Loss of Power Seconds	SNMP trap and TL1 autonomous messages are sent if the number of LPRS events in a 15-minute interval meets or exceeds the selected value (0–900 seconds, where 0 disables the messages).
Errored Seconds	SNMP trap and TL1 autonomous message are sent if the number of ES events in a 15-minute interval meets or exceeds the selected value (0–900 seconds, where 0 disables the messages).
Severely-Errored Seconds	SNMP trap and TL1 autonomous message are sent if the number of SES events in a 15-minute interval meets or exceeds the selected value (0–900 seconds, where 0 disables the messages).
Unavailable Seconds	SNMP trap and TL1 autonomous message are sent if the number of UAS events in a 15-minute interval meets or exceeds the selected value (0–900 seconds, where 0 disables the messages).
Increasing Rate	SNMP rate change trap and TL1 autonomous message are sent if the current rate is greater than or equal to the previous rate plus this threshold (0–65535 kbps, where 0 disables the messages).
Decreasing Rate	SNMP rate change trap and TL1 autonomous message are sent if the current rate is less than or equal to the previous rate minus this threshold (0–65535 kbps, where 0 disables the messages).

Field	Description
<i>Upstream / Far End Alarm Profile</i>	
Loss of Frame Seconds	SNMP trap and TL1 autonomous message are sent if the number of LOFS events in a 15-minute interval meets or exceeds the selected value (0–900 seconds, where 0 disables the messages).
Loss of Signal Seconds	SNMP trap and TL1 autonomous message are sent if the number of LOSS events in a 15-minute interval meets or exceeds the selected value (0–900 seconds, where 0 disables the messages).
Loss of Link Seconds	SNMP trap and TL1 autonomous message are sent if the number of LOLS events in a 15-minute interval meets or exceeds the selected value (0–900 seconds, where 0 disables the messages).
Errored Seconds	SNMP trap and TL1 autonomous message are sent if the number of ES events in a 15-minute interval meets or exceeds the selected value (0–900 seconds, where 0 disables the messages).
Severely-Errored Seconds	SNMP trap and TL1 autonomous message are sent if the number of SES events in a 15-minute interval meets or exceeds the selected value (0–900 seconds, where 0 disables the messages).
Unavailable Seconds	SNMP trap and TL1 autonomous message are sent if the number of UAS events in a 15-minute interval meets or exceeds the selected value (0–900 seconds, where 0 disables the messages).
Increasing Rate	SNMP rate change trap and TL1 autonomous message are sent if the current rate is greater than or equal to the previous rate plus this threshold (065535 kbps, where 0 disables the messages).
Decreasing Rate	SNMP rate change trap and TL1 autonomous message are sent if the current rate is less than or equal to the previous rate minus this threshold (065535 kbps, where 0 disables the messages).
Init Failure	Specify whether initialization failure generates InitFailureTrap messages as specified in RFC 2662. <ul style="list-style-type: none"> <li>■ Yes - Enable Initialization Failure Trap messages.</li> <li>■ No - Disable Initialization Failure Trap messages.</li> </ul>

3. Click on Apply.

## Creating Alarm Threshold Profiles for Model 8985

### ► Procedure

To create an alarm threshold profile for an SHDSL line card:

1. Click on Create New Profile. The Alarm Threshold Profile Create screen appears.
2. Enter or select the following fields:

Field	Description
Profile Name	Specify a name for this alarm profile.
Loop Attenuation Threshold	Specify a loop attenuation alarm threshold of 0–127 dB. An SNMP Loop Attenuation crossing trap message and a TL1 autonomous message may be sent if the current loop attenuation reaches or exceeds this threshold. A Loop Attenuation alarm will also be declared when the current Loop Attenuation exceeds this value. A value of 0 disables event notifications for the condition.
SNR Margin	Specify an SNR Margin alarm threshold of 0–15 dB. An SNMP Margin crossing trap message and a TL1 autonomous message may be sent if the current SNR Margin reaches or drops below this threshold. An SNR Margin alarm will also be declared when the current SNR Margin has dropped below this value. A value of 0 disables event notifications for the condition.
Errored Seconds	Specify an ES threshold of 0–900 seconds. An SNMP ES trap message and a TL1 autonomous message may be sent if the number of ES events in a 15-minute interval equals or exceeds the selected value. At most one SNMP and one TL1 notification will be sent per interval per device. A value of 0 disables event notifications for the condition.
Severely-Errored Seconds	Specify an SES threshold of 0–900 seconds. An SNMP SES trap message and a TL1 autonomous message may be sent if the number of SES events in a 15-minute interval equals or exceeds the selected value. At most one SNMP and one TL1 notification will be sent per interval per device. A value of 0 disables event notifications for the condition.
Code Violations	Specify a Code Violations threshold of 0–900 seconds. An SNMP code violations trap message and a TL1 autonomous message may be sent if the number of Code Violations in a 15-minute interval equals or exceeds this threshold. At most one SNMP and one TL1 notification will be sent per interval per device. A value of 0 disables event notifications for the condition.

---

<b>Field</b>	<b>Description</b>
Loss of Sync Word Seconds	Specify a Loss of Sync Word Seconds threshold of 0–900 seconds. An SNMP LOSWS trap message and a TL1 autonomous message may be sent if the number of LOSWS in a 15-minute interval equals or exceeds this threshold. At most one SNMP and one TL1 notification will be sent per interval per device. A value of 0 disables event notifications for the condition.
Unavailable Seconds	Specify an Unavailable Seconds threshold of 0–900 seconds. An SNMP UAS trap message and a TL1 autonomous message may be sent if the number of UAS events in a 15-minute interval equals or exceeds the selected value. At most one SNMP and one TL1 notification will be sent per interval per device. A value of 0 disables event notifications for the condition.

3. Click on Apply.

## Configuring Cross Connections

Use the Configuration - Cross Connect screen to establish or delete Virtual Channel Connections (VCCs) by port or by slot. Connections may be established between any combination of:

- Subtended ports
- DSL ports
- Network interface (uplink)

### Default Mappings

A DSL port's data VPI/VCI is always 0,35.

Default VC mappings to the SCP card for data service may be determined so:

- VPI is 2 for ports 1–24 and 3 for ports 25–48
- VCI is (Slot \* 24) + (Port number up to 24) + 7

Port numbers 25 through 48 are reduced (by 24) to 1 through 24, respectively, in calculating VCI. So the VCI for Slot 3, Port 1 is the same as the VCI for Slot 3, Port 25:

$$\text{Slot 3, Port 1: } 3 \times 24 + 1 + 7 = 80$$

$$\text{Slot 3, Port 25: } 3 \times 24 + 25 - 24 + 7 = 80$$

### Adding a Port-to-Port Cross Connection

#### ► Procedure

To create a cross connection between specified ports:

1. On the Configuration - Cross Connect screen, click on Create New Cross Connect. The Configuration - Cross Connect Create screen appears.
2. Enter or select the following fields:

Field	Description
<i>Port A</i>	
Slot	Select from the drop-down list the slot where the card associated with this port resides.
Port	Select the port for the cross-connection.
VPI	Enter the VPI for this side of the cross-connection.
Start VCI	Enter the first VCI for this side of the cross-connection.

Field	Description
End VCI	Enter the last VCI for this side of the cross-connection.
Segment End Point	Select True or False from the drop-down list to signify whether this connection is the segment endpoint. This field determines if the port card will function as an endpoint for ATM OAM loopbacks. If False, the port card will loop back a cell only if its location ID matches the preconfigured location ID. (See <a href="#">Configuring ATM Ports</a> on page 3-16.) All other loopback cells are passed to the next segment.
<i>Port B</i>	
Slot	Select from the drop-down list the slot where the card associated with this port resides.
Port	Select the user port for the cross-connection.
VPI	Enter the VPI for the user side of the cross-connection.
Start VCI	Enter the first VCI for the user side of the cross-connection.
End VCI	Enter the last VCI for the user side of the cross-connection.
Segment End Point	Select True or False from the drop-down list to signify whether this connection is the segment endpoint. This field determines if the port card will function as an endpoint for ATM OAM loopbacks. If False, the port card will loop back a cell only if its location ID matches the preconfigured location ID. (See <a href="#">Configuring ATM Ports</a> on page 3-16.) All other loopback cells are passed to the next segment.
<i>Profiles</i>	
Port B to Port A Profile	Select a profile for upstream traffic.
Port A to Port B Profile	Select a profile for downstream traffic.

3. Click on Apply.

## Adding a Slot-to-Slot Cross Connection

### ► Procedure

To create a range of VCCs between specified slots and the SCP card:

1. On the Configuration - Cross Connect screen, click on Create Cross Connect by Slot. The Configuration - Cross Connect - Slot screen appears.
2. Enter or select the following fields:

Field	Description
Start Slot	Select from the drop-down list the first slot in a range to have connections established to the SCP card.
End Slot	Select from the drop-down list the last slot in a range to have connections established to the SCP card. It may be the same as the Start Slot.
Start Port	Select from the drop-down list the first port in a range to have a connection established to the SCP card. The range of ports will be applied to all slots selected.
End Port	Select from the drop-down list the last port in a range to have a connection established to the SCP card. It may be the same as the Start Port. The range of ports will be applied to all slots selected.
Slot VPI	Enter the VPI of this circuit.
Slot VCI	Enter the VCI of this circuit.
Segment End Point (Slot)	Select True or False from the drop-down list to signify whether this connection is the segment endpoint. This field determines if the port card will function as an endpoint for ATM OAM loopbacks. If False, the port card will loop back a cell only if its location ID matches the preconfigured location ID. (See <a href="#">Configuring ATM Ports</a> on page 3-16.) All other loopback cells are passed to the next segment.
SCP VPI	Enter the VPI of this range of VCCs.
SCP Start VCI	Enter the first VCI of this range of VCCs.
Segment End Point	Select True or False from the drop-down list to signify whether this connection is the segment endpoint. This field determines if the port card will function as an endpoint for ATM OAM loopbacks. If False, the port card will loop back a cell only if its location ID matches the preconfigured location ID. (See <a href="#">Configuring ATM Ports</a> on page 3-16.) All other loopback cells are passed to the next segment.
Upstream Profile	Select a profile for upstream traffic.
Downstream Profile	Select a profile for downstream traffic.

For example, if:

- Start Slot is 1 and End Slot is 2
- Slot VPI and VCI are 0 and 35
- SCP VPI and Start VCI are 2 and 32

The VCCs created have the following VPI,VCI values:

		<u>Slot</u>		<u>SCP Card</u>
Slot 1	Port 1	0,35	→	2,32
	Port 2	0,35	→	2,33
	Port 24	0,35	→	2,55
Slot 2	Port 1	0,35	→	2,56
	Port 2	0,35	→	2,57
	Port 24	0,35	→	2,79

## Configuring ATM Ports

Use the Configuration - ATM Port screen to associate a DSL port or the T1/E1 port with an ATM segment location. ATM segment location ID is a 16-octet field that identifies this ATM interface for OAM F5 loopbacks. When a segment F5 OAM loopback cell is received, the destination segment location in the cell is compared to the segment location ID for the port. If the destination location ID matches the location ID or is all ones, the cell is looped back to the source. If there is not a match, the cell passes through the card.

### ► Procedure

To associate a port with an ATM segment location:

1. Select a Slot and Port from the drop-down lists, and click on Select.
2. Enter an ATM Segment Location ID. The value must be 32 hexadecimal characters or ALLONES. Allowed values are restricted per ITU-T1.610 as follows:
  - The first byte must be 01, 02, 03, FF or 6A.
  - If the first octet is FF, then octets 2–16 must also be FF.
  - If the first octet is 6A, then octets 2–16 must also be 6A.
3. Click on Apply.

## Configuring Traffic Profiles

Use the Configuration - Profile Traffic Descriptor screen to define, modify, and delete ATM traffic profiles.

To create a traffic profile:

1. On the Configuration - Profile Traffic Descriptor screen, click on Create New Profile. The first Configuration - Profile Traffic Descriptor Create screen appears.
2. Select a Class of Service (CoS) from the drop-down list:
  - UBR - Unspecified Bit Rate
  - CBR - Constant Bit Rate
  - nrt-VBR - Non-Real-Time Variable Bit Rate
  - rt-VBR - Real-Time Variable Bit Rate
3. The Configuration - Profile Traffic Descriptor Create - CoS screen appears. What fields are displayed depends on the Class of Service. Enter or select:

Field	Description
Profile Name	Enter a name for this profile.
PCR	Enter a Peak Cell rate from 0 to 351566.
SCR	Enter a Sustainable Cell Rate from 0 to 351566.
CDVT	Enter a Cell Delay Variation Tolerance from 0 to 100000. If you enter 0, a CDVT value is automatically calculated.
MDCR	Enter a Minimum Desired Cell Rate from 0 to 351566.
MBS	Enter a Maximum Burst Size from 0 to 351566.
Tagging	Select Yes or No from the drop-down list to determine if tagging is allowed for this profile.
Traffic Policing	Select Yes or No from the drop-down list to determine if traffic policing is allowed for this profile.
Packet Discard	Select Yes or No from the drop-down list to determine if partial packet discards are allowed for this profile.
Shaping	Select Yes or No from the drop-down list to determine if shaping is allowed for this profile.

4. Click on Apply.



---

# Monitoring

# 4

---

## What to Monitor

This chapter presents information on how to monitor unit status and assess performance.

[Table 4-1, Location of ATM Line Card Information](#), shows on which web interface screens you can find information useful in reporting and diagnosing problems.

**Table 4-1. Location of ATM Line Card Information (1 of 2)**

Field	Screen
Code Violation alarm	Status - DSL or SHDSL Performance
DC Continuity Fault alarm	Status - DSL or SHDSL Performance
Errored Second alarm	Status - DSL or SHDSL Performance
Errored Seconds	Status - DSL or SHDSL Statistics
Firmware Revision	System - Firmware or System - Slot Information
Hardware Revision	System - Slot Information
Loop Attenuation	Status - DSL or SHDSL Performance
Loss of Synchronization Word alarm	Status - DSL or SHDSL Performance
Loss of Synchronization Word Seconds	Status - DSL or SHDSL Statistics
Model Number	System - Slot Information
No Neighbor Present alarm	Status - DSL or SHDSL Performance
Protocol Initialization Failure alarm	Status - DSL or SHDSL Performance
Serial Number	System - Slot Information
Severely Errored Second alarm	Status - DSL or SHDSL Performance
Severely Errored Seconds	Status - DSL or SHDSL Statistics
SNR Margin Defect alarm	Status - DSL or SHDSL Performance
Syslog	Status - Syslog
System Contact	System - System Information

**Table 4-1. Location of ATM Line Card Information (2 of 2)**

Field	Screen
System Location	System - System Information
System Name	System - System Information
Unavailable Second alarm	Status - DSL or SHDSL Performance
Unavailable Seconds	Status - DSL or SHDSL Statistics
Unknown Cell Log	Status - Unknown Cell Log

For example, to view the system log, click on Syslog under Status in the web interface menu frame. The Status - System Log screen appears.

**PARADYNE** SCP R3.0

System  
Configuration  
Tests  
Status  
Status  
System Alarms  
Port Rates  
Syslog  
Unknown Cell Log  
Performance  
DSL  
SHDSL  
OC3  
SFP  
Ethernet  
SCP  
Statistics  
DSL  
SHDSL  
OC3  
ATM

**Status - Syslog**

Slot: Slot B (SCP) Clear Log Refresh

Priority	Date and Time	Message
Error	JAN 4 21:52:23	135.26.22.199 Syslog Started...
Error	JAN 4 21:52:26	135.26.22.199 POST:SFP fault/not installed, sfp stat reg = 0xc1
Error	JAN 4 21:52:40	135.26.22.198 POST:uplink tc POST ioctl failed
Critical	JAN 4 21:52:43	135.26.22.198 PowerSupply-B Alarm Up
Information	JAN 4 21:52:45	135.26.22.198 BOOTP process completed for slot 14.
Critical	JAN 4 21:52:57	135.26.22.198 Power On Self Test Failure
Error	JAN 4 21:52:57	135.26.22.198 LOCD Alarm Up for Slot:20, Port:1
Information	JAN 4 21:52:57	135.26.22.198 Sonet Line AIS Alarm Up for Port:1
Information	JAN 4 21:52:57	135.26.22.198 Sonet Section LOF Alarm Up for Port:1 (Slot 20)
Information	JAN 4 21:52:57	135.26.22.198 Sonet Section LOS Alarm Up for Port:1 (Slot 20)
Information	JAN 4 21:52:57	135.26.22.198 Sonet PATH AIS Alarm Up for Port:1 (Slot 20)
Information	JAN 4 21:52:57	135.26.22.198 Sonet Path RDI Alarm Up for Port:1 (Slot 20)
Critical	JAN 4 21:52:58	135.26.22.198 Power On Self Test Failure
Error	JAN 4 21:53:06	135.26.22.198 LOCD Alarm Up for Slot:14, Port:1
Critical	JAN 4 21:53:06	135.26.22.198 Power On Self Test Failure

Use the online Helps to obtain information about the System and Status displays.

## Front Panel LEDs (Models 8955, 8965, 8975, and 8985)

The following table describes the meaning and states of the LEDs on the front panel of the Model 8955, 8965, 8975, and 8985 line cards. The Model 8955 (not shown) has the same LED designations and behaviors as the Model 8965.

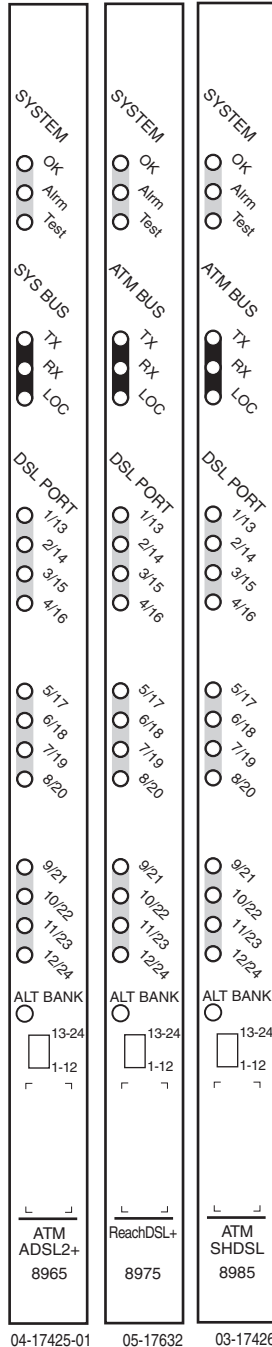

Type	LED	LED is . . . *	Indicating . . .
SYSTEM	OK	Green, On	Card failure. System processing functions have stopped.
		Off	No power to card.
		Green, Pulsing Green, Fast Blinking	Card functioning normally. Firmware download needed.
SYSTEM	Alarm	Amber, On	Alarm is present on the card. ATM interface is not being detected.
		Off	Normal operation, no alarms.
SYSTEM	Test	Amber, On	Test in progress.
		Off	Normal operation, no tests.
		Amber, Fast Blinking	Self-test is in progress.
ATM BUS or SYS BUS	TX	Off	Inactive.
		Green, Fast Blinking	Cells are being transmitted.
	RX	Off	Inactive, link down.
ATM BUS or SYS BUS	RX	Green, Fast Blinking	Cells are being received.
		Off	
ATM BUS or SYS BUS	LOC	Amber, On	Loss Of Clock. Bus clock signal is not present.
		Off	Normal operation.
DSL PORT	1/13–12/24	Green, On	Good signal, unit is trained.
		Off	Port is disabled.
		Green, Slow Blinking Green, Fast Blinking	Port is in test, or is down. Port is training.
ALT BANK		Off	The ports not currently displayed by the port status LEDs are functioning normally or are disabled.
		Amber, Fast Blinking	One of the ports not currently being displayed by the port status LEDs is down, in test, or in training mode.

\* Pulsing: LED turns off momentarily once per second.

Slow Blinking: LED turns on momentarily once per second.

Fast Blinking: LED turns off and on in equal duration 4 times per second.

## Front Panel LEDs (Model 8968)

The following table describes the meaning and states of the LEDs on the front panel of the Model 8968 line card. The card has 24 LEDs to show the state of DSL ports. Depending on the setting of the switch on the face of the card, the LEDs reflect the state of ports 1–24 or 25–48.

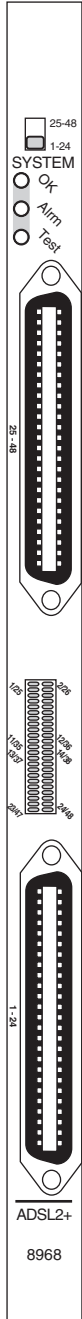

Type	LED	LED is . . . *	Indicating . . .
SYSTEM	OK	Green, On	Card failure. System processing functions have stopped.
		Off	No power to card.
		Green, Pulsing	Card functioning normally.
SYSTEM	Alarm	Green, Fast Blinking	Firmware download needed.
		Amber, On	Alarm is present on the card. ATM interface is not being detected.
		Off	Normal operation, no alarms.
SYSTEM	Test	Amber, On	Test in progress.
		Off	Normal operation, no tests.
		Amber, Fast Blinking	Self-test is in progress.
DSL PORT	1/25–24/48	Green, On	Good signal, unit is trained.
		Off	Port is disabled.
		Green, Slow Blinking	Port is in test, or is down.
		Green, Fast Blinking	Port is training.

\* Pulsing: LED turns off momentarily once per second.  
 Slow Blinking: LED turns on momentarily once per second.  
 Fast Blinking: LED turns off and on in equal duration 4 times per second.

04-17507

## Overview

The ATM line cards provide the following diagnostic tools:

- [Lamp Test](#) on page 5-1
  - Tests the front panel LEDs on a line card.
- [Loopback Test \(Model 8985 Only\)](#) on page 5-2
  - Performs Loopback test on the SHDSL span of the network for Model 8985 cards.

## Lamp Test

Use the Tests - Lamp Test screen to verify that the front panel LEDs on line card are functional.

### ► Procedure

To test the LEDs:

1. Select a Slot from the drop-down list.
2. Click on Start Lamp Test. The button changes to Stop Lamp Test, and power is applied to all LEDs on the card's front panel.
3. When you have checked the LEDs, click on Stop Lamp Test.

If all LEDs did not light up, contact your service representative.

## Loopback Test (Model 8985 Only)

Use the Tests - SHDSL Loopbacks screen to start and stop line loopback tests.

### ► Procedure

To run a SHDSL loopback test:

1. Click on Configure Test(s). The SHDSL Loopback Tests setup screen appears.
2. Select a Slot from the drop-down list.
3. For any port and direction (STUC or STUR), click on the associated Payload Loopback button if you want the loopback to include a data payload.
4. For any port and direction, click in the Start box if you want the entity to be included in the loopback tests.
5. Click on Start Selected. The button changes to Stop Selected.
6. When you have completed testing, click on Stop Selected.

---

# Maintenance Procedures

# 6

---

## Overview

This chapter provides instructions on how to perform miscellaneous maintenance procedures:

- [Uploading and Downloading a Configuration](#) on page 6-2
- [Downloading and Switching Firmware](#) on page 6-4
- [Restarting the Line Card](#) on page 6-5

## Uploading and Downloading a Configuration

Your configuration options for the BLC reside in a file in memory on the SCP card. This file may be saved for purposes of disaster recovery by uploading it to an FTP (File Transfer Protocol) server. A configuration file may be restored by downloading it from an FTP server.

Use the System - Save and Restore screen to:

- Save (upload) the configuration to an external file using FTP.
- Restore (download) the configuration from an external file using FTP. A downloaded configuration file remains in the memory of the SCP card until it is overwritten by another downloaded configuration file, or until the SCP card is reset to factory defaults.
- Reset the SCP card using factory default configuration settings
- Reset the SCP card using downloaded configuration settings

### ► Procedure

To upload and download configurations:

1. In the Configuration (FTP) box, set the parameters as shown in the following table.

Configuration (FTP) Parameters	
FTP Server IP Address	Specify the network address of the FTP server where the configuration is to be uploaded to or downloaded from. For example: <b>137.90.128.10</b>
User Name	Specify a user name accepted by the FTP server. For example: <b>admin</b>
Password	Specify a password accepted by the FTP server. For example: <b>admpass</b>
Filename	Specify the name or pathname of the configuration file. For example: <b>/configs/may_2003_backup.cfg</b>

2. Click on the:
  - Download button to copy a configuration file to the SCP card
  - Upload button to back up the configuration file to a server

A Configuration Transfer Status frame is displayed showing the filename, server address, number of bytes transferred, and the Transfer Status.

When the download or upload is complete, Transfer Status changes to "Transfer completed successfully."

## Resetting the Configuration to Default Settings

### ► Procedure

To reset the running configuration to the default settings:

1. In the Configuration Reset box, click on Reset to Factory Defaults. **Any configuration options you have modified are replaced with default values.**

## Resetting the Configuration to Downloaded Settings

### ► Procedure

To reset the running configuration to the settings in the downloaded file:

1. In the Configuration Reset box, click on Reset to Downloaded file. **Any configuration options you have modified are replaced with the values in the downloaded file.**

## Downloading and Switching Firmware

Use the System - Firmware screen to upgrade firmware or switch versions of firmware in the chassis.

The SCP card has two banks of firmware: the running firmware and alternate firmware. When firmware is downloaded, it is downloaded to the alternate firmware bank. Switching firmware versions changes the running firmware to the dormant (alternate) firmware, and the alternate firmware to the active (running) firmware.

### Downloading Firmware

#### ► Procedure

To download new firmware from an FTP server to the SCP card:

1. Enter or select the appropriate parameters in the Firmware Download box as shown in the following table.

<b>Firmware Download Parameters</b>	
FTP Server IP Address	Specify the network address of the FTP server where the firmware is to be downloaded from. For example: <b>137.90.128.10</b>
User Name	Specify a user name accepted by the FTP server. For example: <b>admin</b>
Password	Specify a password accepted by the FTP server. For example: <b>admnpass</b>
Filename	Specify the name or pathname of the firmware file. For example: <b>/scp_030145.fpi</b>

2. Click on Download. The firmware is downloaded. A Firmware Download Status frame is displayed showing the filename, server address, number of bytes transferred, and the Transfer Status.

When the download is complete, Transfer Status changes to "Transfer completed successfully."

## Switching Firmware

### ► Procedure

To switch between the firmware currently running and alternate firmware stored in the unit:

1. Verify that the Running Firmware and Alternate Firmware displayed in the Firmware box are different versions.
2. Click on the Switch button. The unit is reset and:
  - The Running Firmware becomes the alternate firmware
  - The Alternate Firmware becomes the running firmware
3. Delete the cache used by your web browser before logging into the SCP card:
  - With Internet Explorer, select Tools -> Internet Options. On the General tab, in the Temporary Internet Files box, click on Delete Files.
  - With Netscape, select Edit -> Preferences. Click on Advanced, then click on Cache. On the Cache page, click on Clear Memory Cache, then click on Clear Disk Cache.
4. If you upgrade an 8965 or 8968 line card from a firmware level prior to 3.01.06, you must reset the card. See [Restarting the Line Card](#), below.

## Restarting the Line Card

The System - Restart screen allows you to reset a line card or SCP card and clear its statistics.

This is a software reset that does not power down the unit. However, all links are dropped, and the restarted line card retrains with its DSL endpoint.

### ► Procedure

To restart a card:

1. Select a Slot from the drop-down list and click on Select.
2. Click on the Restart button.



# Connector Pin Assignments



## 8620 and 8820 Telco Connector Pinouts

For 24-port line cards, the Telco 50-pin connectors on the back of the 8620 BLC chassis (numbered 1–3) and the 8820 BLC chassis (numbered 1–18) provide the 2-wire loop interface from each DSL port to either the POTS splitter shelf or, if the loop is not being shared with POTS, then to the Main Distribution Frame (MDF). The following table lists the pin assignments for each of these interfaces.

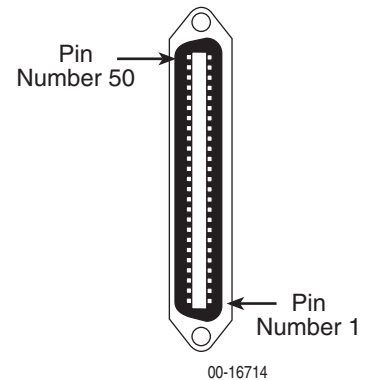

Port	Connector Pins (Tip, Ring)	Port	Connector Pins (Tip, Ring)
Port 1	1, 26	Port 13	13, 38
Port 2	2, 27	Port 14	14, 39
Port 3	3, 28	Port 15	15, 40
Port 4	4, 29	Port 16	16, 41
Port 5	5, 30	Port 17	17, 42
Port 6	6, 31	Port 18	18, 43
Port 7	7, 32	Port 19	19, 44
Port 8	8, 33	Port 20	20, 45
Port 9	9, 34	Port 21	21, 46
Port 10	10, 35	Port 22	22, 47
Port 11	11, 36	Port 23	23, 48
Port 12	12, 37	Port 24	24, 49

Pins 25 and 50 are not used.

## Model 8968 Line Card Telco Connector Pinouts

The Telco 50-pin connectors on the faceplate of the Model 8968 line card provide the 2-wire loop interface from each DSL port to either the POTS splitter shelf or, if the loop is not being shared with POTS, then to the Main Distribution Frame (MDF). The following table lists the pin assignments for each of these interfaces.

The bottom connector (Connector 1) services ports 1–24 and the top connector (Connector 2) services ports 25–48

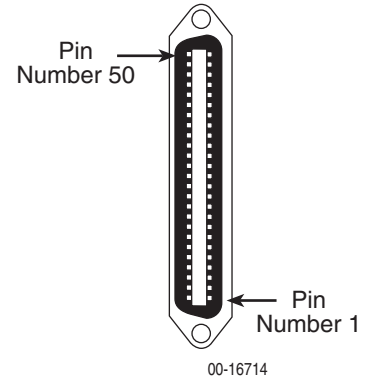

Connector 1 Port	Connector 2 Port	Connector Pins (Tip, Ring)	Connector 1 Port	Connector 2 Port	Connector Pins (Tip, Ring)
Port 1	Port 25	1, 26	Port 13	Port 37	13, 38
Port 2	Port 26	2, 27	Port 14	Port 38	14, 39
Port 3	Port 27	3, 28	Port 15	Port 39	15, 40
Port 4	Port 28	4, 29	Port 16	Port 40	16, 41
Port 5	Port 29	5, 30	Port 17	Port 41	17, 42
Port 6	Port 30	6, 31	Port 18	Port 42	18, 43
Port 7	Port 31	7, 32	Port 19	Port 43	19, 44
Port 8	Port 32	8, 33	Port 20	Port 44	20, 45
Port 9	Port 33	9, 34	Port 21	Port 45	21, 46
Port 10	Port 34	10, 35	Port 22	Port 46	22, 47
Port 11	Port 35	11, 36	Port 23	Port 47	23, 48
Port 12	Port 36	12, 37	Port 24	Port 48	24, 49

Pins 25 and 50 are not used.

---

# Technical Specifications

# B

---

**Table B-1. ATM Line Card Technical Specifications (1 of 2)**

<b>Specifications</b>	<b>Criteria*</b>
<b>Size</b>	Length: 25.4 cm (10 in) Height: 31.1 cm (12.3 in) Width: 2.0 cm (0.8 in)
<b>Weight</b>	
Model 8955	0.9 kg (2.0 lbs)
Model 8965	0.6 kg (1.4 lbs)
Model 8968	0.9 kg (2.0 lbs)
Model 8975	0.7 kg (1.5 lbs)
Model 8985	0.6 kg (1.4 lbs)
<b>Approvals</b>	
<b>Safety Certifications</b>	Refer to the equipment's label for approvals on product.
<b>Power</b>	The ATM Line Card requires –48 VDC power input. The –48 VDC power is distributed through the BLC backplane. Maximum Power Dissipation:
Model 8955	27 watts
Model 8965	27 watts
Model 8968	61 watts
Model 8975	45 watts
Model 8985	45 watts
<b>Physical Environment</b>	
Operating temperature	0° to 50° C (32° to 122° F)
Storage temperature	–20° to 70° C (–4° to 158° F)
Relative humidity	5% to 85% (noncondensing)
Shock and vibration	Withstands normal shipping and handling.

\* Technical specifications are subject to change without notice.

**Table B-1. ATM Line Card Technical Specifications (2 of 2)**

<b>Specifications</b>	<b>Criteria*</b>
<b>Line Code</b>	
Model 8955	ReachDSL 2.2
Models 8965 and 8968	ANSI (ANSI T1.413-1998) G.dmt (ITU G.992.1) G.lite (ITU G.992.2) ADSL2 (ITU G.992.3) ADSL2+ (ITU G.992.5)
Model 8975	ReachDSL 2.2 ANSI (ANSI T1.413-1998) G.dmt (ITU G.992.1) G.lite (ITU G.992.2)
Model 8985	G.shdsl (ITU G.991.2)
<b>DSL Line Rates</b>	
Model 8955	32–2176 kbps
Models 8965 and 8968	Downstream: 32–29000 kbps for ADSL2+ 32–16000 kbps for ADSL2 32–8000 kbps for G.dmt and ANSI 64–3008 kbps for G.lite Upstream: 32–2200 kbps for ADSL2+ 32–1056 kbps for ADSL2 32–832 kbps for ADSL2, ADSL2+, G.dmt, and ANSI 32–512 kbps for G.lite
Model 8975	ReachDSL: 32–2176 kbps ADSL Downstream: 32–8000 kbps for G.dmt and ANSI 64–3008 kbps for G.lite ADSL Upstream: 32–832 kbps for G.dmt, and ANSI 32–512 kbps for G.lite
Model 8985	192–2304 kbps (384–4608 kbps with two wire pairs)

\* Technical specifications are subject to change without notice.

---

# Index

---

## Numerics

- 8955
  - alarm threshold profiles, 3-8
  - configuring ports, 3-2
  - description, 1-1
  - LEDs, 4-3
  - line profiles, 3-6
- 8965
  - alarm threshold profiles, 3-8
  - configuring ports, 3-3
  - description, 1-1
  - LEDs, 4-3
  - line profiles, 3-6
- 8968
  - alarm threshold profiles, 3-8
  - configuring ports, 3-3
  - connectors, A-2
  - description, 1-1
  - LEDs, 4-4
  - line profiles, 3-6
- 8975
  - alarm threshold profiles, 3-8
  - configuring ports, 3-2
  - description, 1-1
  - LEDs, 4-3
  - line profiles, 3-6
- 8985
  - alarm threshold profiles, 3-10
  - configuring ports, 3-5
  - description, 1-1
  - LEDs, 4-3
  - line profiles, 3-7
  - loopback tests, 5-2

## A

### ADSL

- configuring ports, 3-3
- line profiles, 3-6

### alarms

- threshold profiles, 3-8, 3-10
- where displayed, 4-1

### applications

- multiple protocols, 1-3
- voice over DSL, 1-3

## ATM

- ports, configuring, 3-16
- statistics, 1-2

## C

- classes of service, 1-2
- Code Violation alarm, 4-1
- configuration, 3-1
  - ADSL ports, 3-3
  - alarm threshold profiles, 3-8, 3-10
  - ATM ports, 3-16
  - cross connections, 3-12
  - example of network, 1-3
  - line profiles, 3-6
  - ReachDSL ports, 3-2
  - saving, 6-2
  - SHDSL ports, 3-5
  - tab, 2-2
  - traffic profiles, 3-17
  - upload and download, 6-2
- cross connections, 3-12

## D

- data rate
  - adaptation, 1-3
- DC Continuity Fault alarm, 4-1
- dimensions, B-1
- documents, related, iv
- downloading
  - a configuration, 6-2
  - firmware, 6-4
- DSL ports
  - ADSL, 3-2
  - ReachDSL, 3-2
  - SHDSL, 3-5

## E

- ending a session, 2-2
- endpoint support, 1-2
- environment requirements, B-1
- Equivalent Working Length, 3-5
- Errored Second alarm, 4-1
- Errored Seconds, 4-1
- example network, 1-3

**F**

- features, 1-2
- firmware
  - download, 6-4
  - revision number, 4-1
- front panel LEDs, 4-3

**G**

- glossary, iv
- GrandVIEW, 1-4

**H**

- Hardware Revision, 4-1
- Help, 2-2

**L**

- lamp test, 5-1
- LEDs, 4-3
- line profiles
  - ADSL, 3-6
  - ReachDSL, 3-6
  - SHDSL, 3-7
- login, 2-1
- logout, 2-2
- Loop Attenuation, 4-1
- loopback test, 5-2
- Loss of Synchronization Word alarm, 4-1
- Loss of Synchronization Word Seconds, 4-1

**M**

- maintenance procedures, 6-1
- menus, 2-2
  - described, 2-1
- MIBs
  - list of supported, 1-4
- Model 8620 and 8820 connectors, A-1
- Model 8968 connectors, A-2
- Model Number, 4-1
- monitoring, 4-1

**N**

- network example, 1-3
- No Neighbor Present alarm, 4-1

**O**

- online Help, 2-2

## overview

- ADSL, 1-1
- ATM line cards, 1-1
- card features, 1-2
- device features, 1-2
- maintenance procedures, 6-1
- ReachDSL, 1-1
- SHDSL, 1-1
- tests, 5-1
- user interfaces, 2-1, 3-1
- user's guide, iii

**P**

- performance, 4-1
- physical environment requirements, B-1
- pin assignments, A-1–A-2
- port-to-port cross connections, 3-12
- Power Management (ADSL2), 3-4
- power requirements, B-1
- product-related documents, iv
- profiles
  - alarm threshold, 3-8, 3-10
  - line, 3-6
  - traffic, 3-17
- Protocol Initialization Failure alarm, 4-1

**R**

- ReachDSL
  - line profiles, 3-6
- related documents, iv
- reset
  - card, 6-5
  - to downloaded settings, 6-3
  - to factory defaults, 6-2
- restart card, 6-5
- restoring configuration from server, 6-2

**S**

- save configuration to server, 6-2
- saving a configuration, 6-2
- screens, how to use, 2-1
- Serial Number, 4-1
- Severely Errored Second alarm, 4-1
- Severely Errored Seconds, 4-1
- SHDSL
  - line profiles, 3-7
  - loopback, 5-2
  - ports, 3-5
- size of card, B-1
- slot-to-slot cross connections, 3-14

**SNMP**

- general management capabilities, 1-4
- MIBs supported, 1-4
- trap support, 1-4

**SNR Margin Defect alarm, 4-1**

software reset, 6-5

spectrum management, 3-1

**speeds**

- automated adjustment, 1-3

status, 4-1

Syslog status, 4-1

**System**

Contact, 4-1

Location, 4-2

Name, 4-2

**T**

technical manuals, iv

technical specifications, B-1

Telco 50-pin connectors, A-1–A-2

test, 5-1

LEDs, 5-1

procedures, 5-1

SHDSL, 5-2

threshold profiles, 3-8, 3-10

traffic profiles, 3-17

traps, 1-4

**U**

Unavailable Second alarm, 4-2

Unavailable Seconds, 4-2

Unknown Cell Log, 4-2

uploading a configuration, 6-2

**user interface**

configuration of card, 3-1

how to use, 2-1

monitoring, 4-1

**V**

voice over DSL, 1-3

**W****web interface**

accessing, 2-1

menu tabs, 2-2

website, Paradyne technical manuals, iv

weight of card, B-1

