

## iMarc™ SLV ISDN Dial Backup Module (DBM) Installation Instructions

NOTE: The FrameSaver® product line has been renamed to iMarc.

Document Number 9098-A2-GN10-40

Feature Number 9098-F1-870 (BRI) and 9098-F1-875 (PRI)

May 2003

---

Use these instructions for iMarc SLV models 9126, 9128, and 9128-II, with a Current Software Revision of 1.3.x, or greater. To determine the iMarc unit's (NAM's) software revision, select *Main Menu* → *Status* → *Identity*.

### Product Documentation Online

Complete documentation for this product is available at [www.paradyne.com](http://www.paradyne.com). Select *Support* → *Technical Manuals* → *iMarc IP/Frame Relay Devices*.

Select the following documents:

- iMarc Technical Description* (9000-A2-GB30)
- iMarc Configuration Reference* (9000-A2-GB31)
- iMarc SNMP Reference* (9000-A2-GB32)
- iMarc Operations Guide* (9000-A2-GB33)

To order a paper copy of a Paradyne document, or to speak with a sales representative, please call 1-727-530-2000.

### Package Checklist

Verify that your package contains the following:

- Dial Backup Module (DBM)
- Standoff posts, screws, and washers:
  - **BRI DBM:** 2 standoff posts, 4 screws, 4 washers, 1 nylon standoff
  - **PRI DBM:** 3 standoff posts, 6 screws, 6 washers

Be sure to register your warranty at [www.paradyne.com/warranty](http://www.paradyne.com/warranty).

---

# Before You Begin

Make sure you have:

- One of the following ISDN services ordered and installed.
  - **BRI Service:** Capability Package B for 1B-channel service (supporting up to two circuit-switched B-channels, BRI-B1 and BRI-B2), with one Service Profile Identification (SPID) number and one local phone number.  
  
Capability Package R for 2B-service (supporting up to two circuit-switched B-channels, BRI-B1 and BRI-B2), with two SPID numbers and two local phone numbers.  
  
Busy Fixed Call Forwarding for the answering system (typically the central site system) is recommended if getting Capability Package R (2B-service). This feature is only required if all remote systems will call the same phone number. Busy Fixed Call Forwarding forwards a call to the BRI-B2 channel when the BRI-B1 channel is busy.
  - **PRI Service:** NI-2, AT&T 4ESS, or AT&T 5ESS custom (supporting up to 23 B-channels), with Circuit-Switched Data capability.
- One of the following ISDN cables (20 feet / 6.1 meters).
  - **BRI:** RJ49C ISDN-U cable if an iMarc unit with an ISDN BRI DBM.
  - **PRI:** RJ48C cable if an iMarc unit with an ISDN PRI DBM.
- Configuration information for the iMarc unit and the DBM.
  - Local phone number for the DBM.
  - SPIDs (service profile IDs) for a BRI DBM.
  - Outbound Phone Numbers for the calling unit.
  - CNIS (calling number identification service) and Inbound Calling IDs for the answering unit.
- Tools:
  - **1-Slot Unit:** Small flat-blade screwdriver and small Phillips screwdriver.
  - **NAM (Network Access Module):** Phillips screwdriver.

## CAUTION:

**Do not install a BRI DBM on an iMarc 9128 or 9128-II NAM that goes into a multislot housing. A BRI DBM is designed for 1-slot units only. Installing a BRI DBM on a 9128 or 9128-II NAM going into a 14-slot housing will void your warranty.**

---

See the User's Guide for additional information on:

- Troubleshooting
- Technical Specifications
- Connectors, Cables, and Pin Assignments

## Safety Instructions

Please read the Important Safety Instructions that come with the iMarc unit.

### HANDLING PRECAUTIONS FOR STATIC-SENSITIVE DEVICES

**This product is designed to protect sensitive components from damage due to electrostatic discharge (ESD) during normal operation. When performing installation procedures, however, take proper static control precautions to prevent damage to equipment. If you are not sure of the proper static control precautions, contact your nearest sales or service representative.**



Before upgrading a NAM with the DBM feature, or replacing either, locate or record the iMarc unit's configuration options, or transfer the configuration using the FTP (file transfer protocol) feature (refer to the User's Guide). This may be useful when setting up again, verifying operation, or troubleshooting.

---

## Removing the NAM from Its Housing

Select the appropriate procedure for removing the NAM from its housing. See *Removing the NAM from a Multislot Housing* on page 5 if the NAM is in a multislot housing.

### Removing the NAM from a 1-Slot Housing

1. Disconnect the power cord/transformer, first from the power outlet, then from the rear of the iMarc unit.
2. Disconnect the other cables.
3. Using a small flat-blade screwdriver, gently pry open the housing at each of the four connecting tab points.

Be careful not to damage the housing (using a screwdriver that is too big could damage the housing).

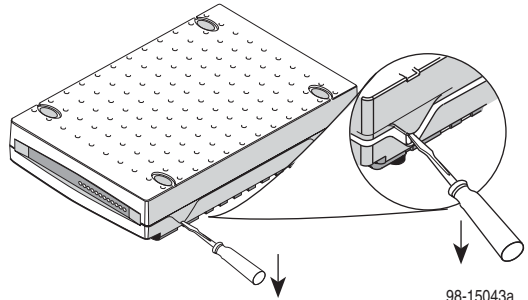

4. Remove the cover and lift the NAM and its integrated I/O card/backplane (rear panel) from the base.

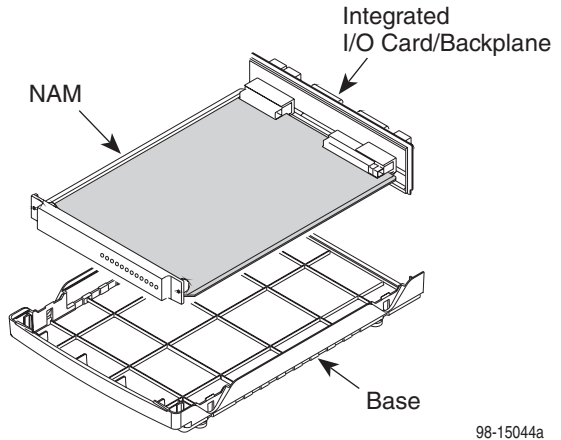

5. Lay the NAM on an electrostatic discharge-protective work surface, component side up, with the card connectors on the left-hand side.

---

## Removing the NAM from a Multislot Housing

1. Unscrew the captive screws from the ejector latches on front of the carrier.
2. Press open the ejector latches to disengage the card.
3. Supporting the card by its edges, pull straight out until the card clears the carrier.
4. Lay the NAM on an electrostatic discharge-protective work surface, component side up, with the card connectors on the left-hand side.

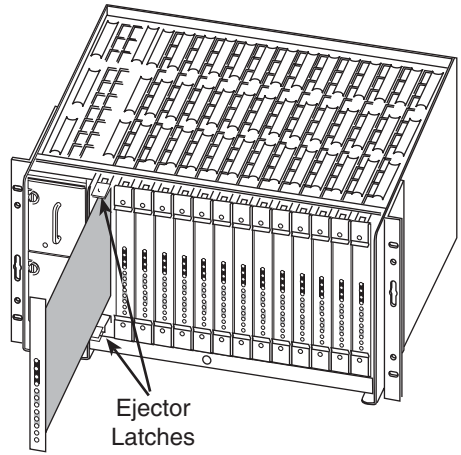

**Front View**

98-16209

Proceed to *Removing a BRI DBM* on page 6 or *Removing a PRI DBM* on page 7 if transferring a DBM to another NAM or replacing a DBM. Otherwise, proceed to *Installing a BRI DBM* on page 8 or *Installing a PRI DBM* on page 9.



---

## Removing a PRI DBM

1. Remove the screws and washers from the three standoff posts that hold the DBM to the NAM, and set them aside.

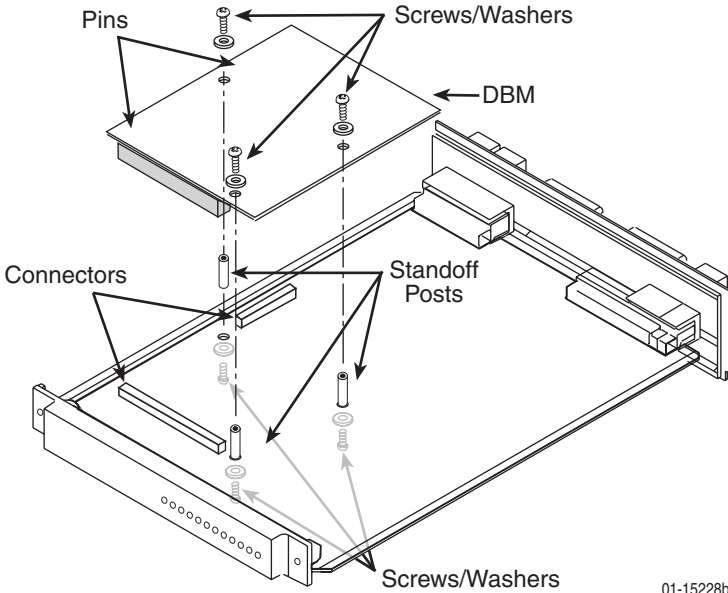

2. Turn the NAM over and remove the screws and washers on the underside of the NAM, and set the standoff posts, screws, and washers aside.
3. Turn the NAM over again so the DBM is on top.
4. Work the DBM away from the NAM by very carefully and gently pulling and rocking the DBM connectors away from the NAM connectors. Work first from one side, then the other until the DBM is free. **Be careful to not bend any pins.**

---

## Installing a BRI DBM

1. Remove the DBM, standoff posts, nylon standoff, screws, and washers from the shipping box.
2. Position a standoff post at one of the two holes in the NAM, put a screw through a washer, insert the screw from the underside of the NAM, and tighten the screw to hold the standoff post in place.

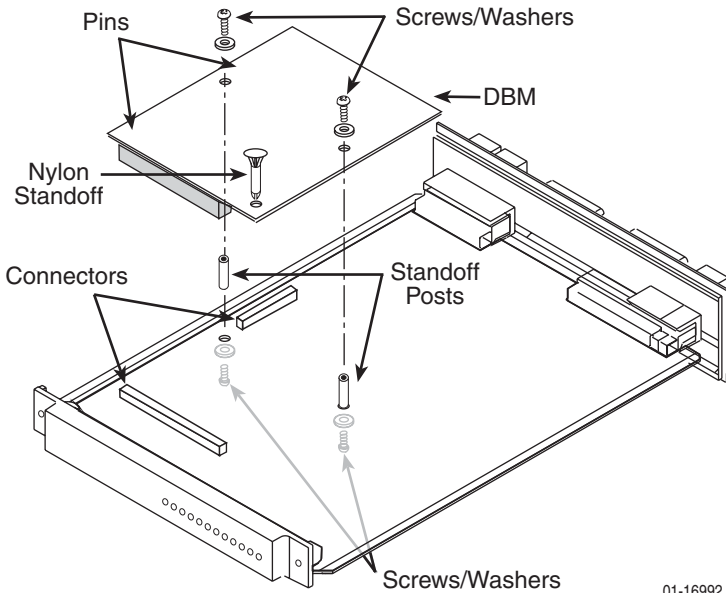

01-16992

3. Install the other standoff post in the same way.
4. Hold the DBM, pin side down, so the two sets of pins are aligned with their respective connectors. Carefully match the pins to the holes of the two connectors.
5. Press the pins and connectors together until both pin sets are firmly seated.  
**Be careful to not force or bend any pins.**
6. Insert the remaining screws and washers into the standoff post holes on the DBM, and tighten.
7. Push the pointed end of the nylon standoff into the hole in the corner of the DBM, as shown.

---

## Installing a PRI DBM

1. Remove the DBM, standoff posts, screws, and washers from the shipping box.
2. Position a standoff post at one of the three holes in the NAM, put a screw through a washer, insert the screw from the underside of the NAM, and tighten the screw to hold the standoff post in place.

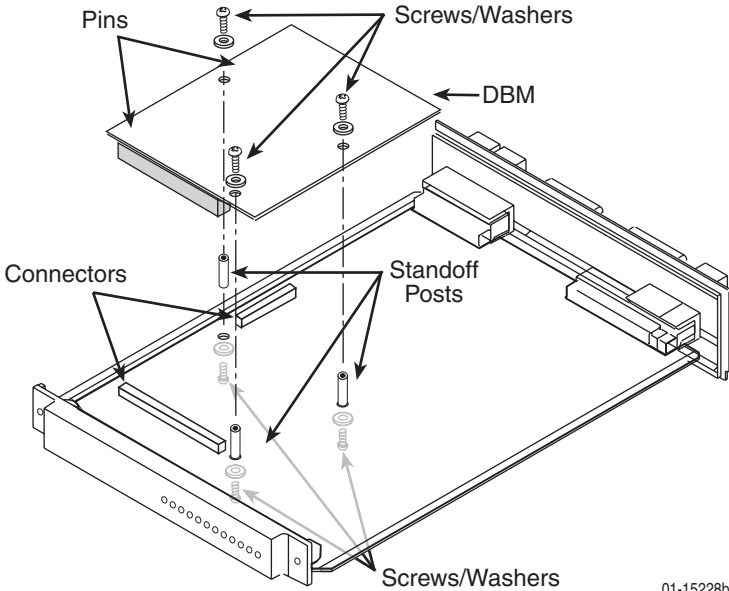

01-15228b

3. Install the other standoff posts in the same way.
4. Hold the DBM, pin side down, so the two sets of pins are aligned with their respective connectors. Carefully match the pins to the holes of the two connectors.
5. Press the pins and connectors together until both pin sets are firmly seated.  
**Be careful to not force or bend any pins.**
6. Insert the remaining screws and washers into the standoff post holes on the DBM, and tighten.

---

## Reinstalling the NAM

Select the appropriate procedure for reinstalling the NAM in its housing.

### Reinstalling the NAM in a 1-Slot Housing

Refer to the illustrations in *Removing the NAM from a 1-Slot Housing* on page 4, if necessary.

1. Reinstall the NAM in its housing, snapping the cover and base together at each of the four connecting tab points.
2. Reconnect the cables.

### Reinstalling the NAM in a Multislot Housing

Refer to the illustration in *Removing the NAM from a Multislot Housing* on page 5, if necessary.

1. Align the NAM with the upper and lower tracks of the slot.
2. Slide forward until the NAM seats. Be careful not to force or bend any pins.
3. Close both the upper and lower ejector latches on the carrier to lock in place, then tighten the captive screws.

# Installing the ISDN Cable

Select the appropriate procedure for the DBM being installed.

- iMarc SLV 9126 – Supports a BRI DBM only.
- iMarc SLV 9128 or 9128-II 1-slot unit – Supports a BRI or PRI DBM.
- iMarc SLV 9128 or 9128-II NAM – Supports a PRI DBM only.

The illustrations below show the iMarc SLV 9128-II 1-slot unit and NAM. The location of the DBM interface may vary based upon the model.

## Installing a BRI Cable

1. Insert the 8-pin connector on the ISDN-U cable into the DBM interface.
2. Insert the other end of the cable into the ISDN service RJ49C jack.
3. Reconnect the power cord, first to the rear of the iMarc unit, then to the power outlet.

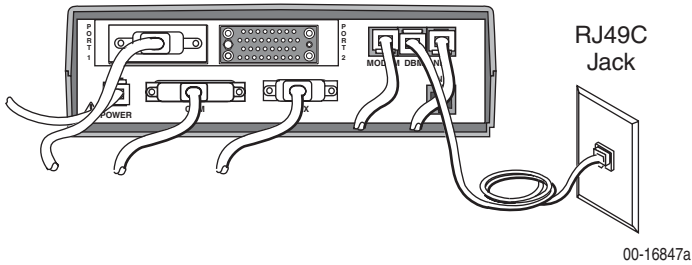

## Installing a PRI Cable

1. Insert the 8-pin connector on the ISDN cable into the DBM interface.
2. Insert the other end of the cable into the ISDN service RJ48C jack.

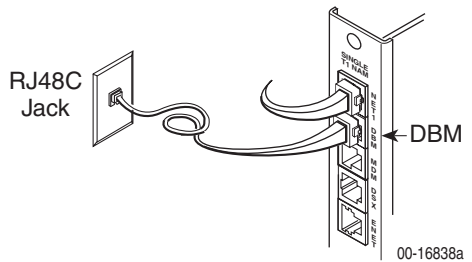

---

# Setting Up the DBM

Once the DBM is installed, it must be set up for dial backup. Another DBM must be installed at the far end before backup can take place. The DBM at either end of the link can place or answer a backup call when there is a failure. However, the recommended method is for remote sites to place the calls (usually with BRI DBMs) and for the central site to answer calls (usually with a PRI DBM). These are the default settings for BRI and PRI DBMs.

The following guidelines apply.

- **Central site** configuration guidelines:
  - Set up the ISDN DBM physical interface.
  - If a BRI DBM, change the Automatic Backup Configuration to Multi\_Site\_Backup. (A PRI DBM is already configured for multisite backup.)
  - Modify the Link Profile(s) that Automatic Backup Configuration created to add a phone number.
- **Remote site** configuration guidelines:
  - Set up the ISDN DBM physical interface.
  - If a PRI DBM, change the Automatic Backup Configuration to Single\_Site\_Backup. (A BRI DBM is already configured for single-site backup.)
  - Modify the HQ\_Site Link Profile that Automatic Backup Configuration created to add a phone number.
  - Set the criteria by which automatic backup will take place.

## Setting Up the DBM Physical Interface

1. Configure the DBM interface.  
*Main Menu → Configuration → ISDN → Physical*

2. Minimally, set the following configuration options:
  - Interface Status is set to Enable.
  - Local Phone Number 1 is entered, plus the following:

<b>iMarc Unit with BRI</b>	<b>iMarc Unit with PRI</b>
Configure the B-channels: <ul style="list-style-type: none"><li>■ Service Profile ID1 (SPID)</li><li>■ Service Profile ID2 (SPID)</li><li>■ Local Phone Number 2</li></ul>	Configure T1 physical characteristics to match the service provider's settings.

3. Save the configuration and return to the ISDN menu.

---

## Setting Up Automatic Backup Configuration

The Automatic Backup Configuration feature is used to automatically create alternate DLCI records and PVC connections on the ISDN DBM (backup) interface.

This feature is already set up in the iMarc units with a DBM.

- Single\_Site\_Backup is the default for a BRI DBM.
- Multi\_Site\_Backup is the default for a PRI DBM.

See the User's Guide for additional information.

## Modifying ISDN Link Profiles

1. Select Link Profiles, then Modify.

The iMarc unit automatically configures an ISDN Link Profile on the first ISDN link, with HQ\_Site as the Link Name. For subsequent ISDN Link Profiles, select New.

2. Add a name and phone number to the ISDN Link Profile(s) created by Automatic Backup Configuration.
  - Name for the destination entered (e.g., Tampa). The default setting is HQ\_Site.
  - Link Status is set to Auto.
  - Phone numbers entered:

For Originating a Backup Call	For Answering a Backup Call
Outbound and Alternate Outbound phone numbers Valid characters include: <ul style="list-style-type: none"><li>■ Numbers (0–9)</li><li>■ Special characters * and #</li><li>■ Spaces</li><li>■ Parentheses ( )</li></ul>	Inbound Calling ID1 and ID2 These are the phone numbers of units from which calls will be accepted. Valid characters include: <ul style="list-style-type: none"><li>■ Numbers (0–9)</li></ul>

### NOTES:

Remember to include local dial-out numbers (i.e., 9, then the number).

For every originating (outbound) phone number entered, an answering (inbound) phone number must be entered at the far end, and vice versa.

- Maximum Link Rate is changed, if necessary. The default setting is 64 Kbps.
3. Save the configuration.

---

## Setting the Criteria for Automatic Backup

1. Enable Auto Backup.

*Main Menu → Configuration → Auto Backup Criteria*

When a failure occurs, the unit automatically enables the Alternate Link and traffic is rerouted over the backup (alternate) interface.

2. Specify When Auto Backup Allowed – Always or Restrict. If Restrict is selected, specify the days and hours of the week during which automatic backup can take place.
3. Save the configuration.

## Verifying the ISDN Line and That Data Can Be Passed Between DBMs

1. Verify the ISDN lines by checking the DBM Interface Status.

*Main Menu → Status → DBM Interface Status*

Line Status should be Active. If an invalid (Inv) status (e.g., Inv SPID for a BRI DBM) is displayed, verify that you entered ISDN physical options correctly.

2. Check backup setup and that data can be passed between DBMs.

- Select Test, then ISDN Call/PVC Tests

*Main Menu → Test → ISDN Call/PVC Tests*

- Select the link to be tested.
- Start a Test Call. The Status should be Active.
- Wait as the originating DBM places the backup call. The originating unit's Test LED is on.

<b>If the Result is . . .</b>	<b>Then . . .</b>
Frame Relay Link Up	The call was successful.
Frame Relay Link Suboptimal	Not all links have come up. Verify that the Maximum Link Rate (Kbps) setting in the ISDN Link Profile is the same at both ends.
Frame Relay Link Down	The call was unsuccessful. Verify the configuration and Link Status in the ISDN Link Profile.

- Select Stop to end the Test Call.

See *Verifying Backup Setup* in *Configuration* of the User's Guide for additional information.

---

## Warranty, Sales, Service, and Training Information

Contact your local sales representative, service representative, or distributor directly for any help needed. For additional information concerning warranty, sales, service, repair, installation, documentation, training, distributor locations, or Paradyne worldwide office locations, use one of the following methods:

- **Internet:** Visit the Paradyne World Wide Web site at [www.paradyne.com](http://www.paradyne.com). (Be sure to register your warranty at [www.paradyne.com/warranty](http://www.paradyne.com/warranty).)
- **Telephone:** Call our automated system to receive current information by fax or to speak with a company representative.
  - Within the U.S.A., call 1-800-870-2221
  - Outside the U.S.A., call 1-727-530-2340

## Document Feedback

We welcome your comments and suggestions about this document. Please mail them to Technical Publications, Paradyne Corporation, 8545 126th Ave. N., Largo, FL 33773, or send e-mail to [userdoc@paradyne.com](mailto:userdoc@paradyne.com). Include the number and title of this document in your correspondence. Please include your name and phone number if you are willing to provide additional clarification.

## Trademarks

FrameSaver is a registered trademark of Paradyne Corporation. iMarc is a trademark of Paradyne Corporation. All other products and services mentioned herein are the trademarks, service marks, registered trademarks, or registered service marks of their respective owners.



\*9098-A2-GN10-40\*