



**ADSL2+
INVERSE
MULTIPLEXER**

● PWR

RX	TX	LK
1	●	●
2	●	●
3	●	●
4	●	●
5	●	●
6	●	●
7	●	●
8	●	●
9	●	●
10	●	●
11	●	●
12	●	●
13	●	●
14	●	●
15	●	●
16	●	●
17	●	●
18	●	●
19	●	●
20	●	●
21	●	●
22	●	●
23	●	●
24	●	●
25	●	●
26	●	●
27	●	●
28	●	●
29	●	●
30	●	●
31	●	●
32	●	●
33	●	●
34	●	●
35	●	●
36	●	●
37	●	●
38	●	●
39	●	●
40	●	●
41	●	●
42	●	●
43	●	●
44	●	●
45	●	●
46	●	●
47	●	●
48	●	●

A
D
S
L
2
+

AIM24000-48



AIM24000-48

and

AIM24000-48B

48-Port ADSL2+ Inverse Multiplexers

© Copyright 2004 Net to Net Technologies, Inc.
™ The Net to Net Logo is a trademark of Net to Net Technologies, Inc.

Worldwide Headquarters
Net to Net Technologies
112 Corporate Drive
Portsmouth, NH 03801 USA
1 (877) 638-2638
support@nettonet.com

<http://www.nettonet.com>

EMEA Headquarters
Net to Net Technologies
Victoria House, 19 Park Way
Newbury Berkshire RG14 1EE UK
44 (0) 1635-570950
support-emea@nettonet.com

Contents

1.0 ADSL2+ INVERSE MULTIPLEXER MODEL TYPES

1.1 AIM24000-48

1.2 AIM24000-48B

2.0 INSTALLATION

2.1 Unpack and Inspect the AIM24000

2.2 Install the AIM24000 in an IP DSLAM

2.2.1 12-Slot IP DSLAM

- 2.2.1.1 Select a Slot for Installation
- 2.2.1.2 Align the AIM24000 with the Slot Module Guides
- 2.2.1.3 Slide the AIM24000 Firmly into the Chassis
- 2.2.1.4 Secure the AIM24000 in the Chassis

2.2.2 4-Slot IP DSLAM

- 2.2.2.1 Select a Slot for Installation
- 2.2.2.2 Align the AIM24000 with the Slot Module Guides
- 2.2.2.3 Slide the AIM24000 Firmly into the Chassis
- 2.2.2.4 Secure the AIM24000 in the Chassis

2.3 Verify Power Reception

2.4 Connect Your ADSL Cable(s)

2.4.1 Local Connection

- 2.4.1.1 12-Slot IP DSLAM
- 2.4.1.2 4-Slot IP DSLAM

2.4.2 Remote Connection

2.4.3 ADSL RJ21 Pinout

2.5 Verify the ADSL Connection(s)

3.0 ADSL Parameters

3.1 Default Configurations

3.2 Parameter Definitions

3.2.1 Circuit ID

3.2.2 Standard Mode

- 3.2.2.1 Multimode
- 3.2.2.2 Full Rate ADSL2
- 3.2.2.3 Full Rate ADSL
- 3.2.2.4 G-lite

3.2.3 Port Mode

- 3.2.3.1 Adaptive
- 3.2.3.2 Fixed
- 3.2.3.3 Fixed Adaptive
- 3.2.3.4 Off

3.2.4 Bandwidth and Distance

- 3.2.4.1 Full Rate ADSL2
- 3.2.4.2 Full Rate ADSL
- 3.2.4.3 G-lite

3.2.5 IP Range

- 3.2.5.1 Single IP Address
- 3.2.5.2 IP Address Range
- 3.2.5.3 Full IP Address Range

3.2.6 VLAN

3.2.7 Backbone-VLAN

3.2.8 VLAN Priority

3.2.9 Protocol

- 3.2.9.1 All
- 3.2.9.2 Select

- 3.2.10 Flood**
 - 3.2.10.1 Uplink
 - 3.2.10.2 VLAN
- 3.2.11 Frame Type**
 - 3.2.11.1 1438LLC
 - 3.2.11.2 1483VCM
- 3.2.12 VPI/VCI Detect**
 - 3.2.12.1 On
 - 3.2.12.2 Off
 - 3.2.12.3 Manual

4.0 AIM24000 Management

4.1 Via NMS

- 4.1.1 Log In**
- 4.1.2 Circuit Configuration**
 - 4.1.2.1 Verify Port Information
 - 4.1.2.2 Circuit Identification
 - 4.1.2.3 Port Mode
 - 4.1.2.4 VPI/VCI Detect
 - 4.1.2.5 IP Range
 - 4.1.2.6 Protocol
 - 4.1.2.7 DHCP Option 82
 - 4.1.2.8 Layer 2 Port Filters
 - 4.1.2.9 Frame Type
 - 4.1.2.10 Standard Mode
 - 4.1.2.11 Submit
- 4.1.3 VLAN Rules**

4.2 Via CLI

- 4.2.1 Log In**
- 4.2.2 Circuit Configuration**
 - 4.2.2.1 Circuit Identification
 - 4.2.2.2 Standard Mode
 - 4.2.2.3 Port Mode
 - 4.2.2.4 Speed
 - 4.2.2.5 IP Range
 - 4.2.2.6 VLAN Range
 - 4.2.2.7 Backbone-VLAN
 - 4.2.2.8 VLAN Priority
 - 4.2.2.9 Protocol
 - 4.2.2.10 Flood
 - 4.2.2.11 Frame Type
 - 4.2.2.12 VPI/VCI Detect

4.3 Via SNMP

- 4.3.1 Contact your IP DSLAM**
- 4.3.2 Circuit Configuration**

5.0 ADDITIONAL INFORMATION

5.1 LED Indications

5.2 DATA STORAGE

- 5.2.1 Memory**
 - 5.2.1.1 RAM
 - 5.2.1.2 NVRAM
- 5.2.2 Local Files**
 - 5.2.2.1 Uploading a Port Template
 - 5.2.2.2 Downloading a Port Template

5.3 Firmware Upgrades

5.4 Regulatory Compliance for Class A Equipment

1.0 ADSL2+ INVERSE MULTIPLEXER MODEL TYPES

1.1 AIM24000-48

The AIM24000-48 is a 48-port ADSL2+ inverse multiplexer that supports Annex A (Plain Old Telephone Service-POTS) on lower end frequencies (up to 4 kHz).

1.2 AIM24000-48B

The AIM24000-48B is a 48-port ADSL2+ inverse multiplexer that supports Annex B (Integrated Services Digital Network-ISDN) on lower end frequencies: up to 80 kHz over a Two Binary, One Quaternary (2B1Q) line and up to 100 kHz over a Four Binary, Three Ternary (4B3T) line.

2.0 INSTALLATION

CAUTION Net to Net Technologies strongly recommends the use of proper electrostatic discharge (ESD) precautions when handling this equipment.

2.1 Unpack and Inspect the AIM24000

AIM24000 SPECIFICATIONS

12.75" High x 1.15" Wide x 16.75" Deep
(32.4cm x 2.9cm x 42.5cm)
3.6 lbs (1.6 kg)

If there is visible damage, do not attempt to connect the device. Contact Customer Support: customers in Europe, the Middle East and Africa please call 44-0-1635-570953 or email support-emea@nettonet.com ; customers in the United States please call 1-877-638-2638 or email support@nettonet.com. All other customers please call 1-603-427-0600 or email support@nettonet.com.

2.2 Install the AIM24000 in an IP DSLAM

There must be a management module, complete with an uplink module, installed in your IP DSLAM chassis in order for the AIM24000 to operate.

NOTE All of Net to Net Technologies' IP DSLAM interface modules are hot swappable; installing or removing an interface module while the chassis is powered up does not affect the operational status of other interface modules within the chassis.

AIM24000 OPERATING REQUIREMENTS

Operating Temperature:
32°F to 122°F (0°C to 50°C) in an IPD12000E
-40°F to 149°F (-40°C to 65°C) in an IPD4000E
Non-Operating Temperature: -40°F to 158°F (-40°C to 70°C)
Humidity: 5% to 95%, non-condensing
Altitude: -200 ft to 16,500ft (-60m to 5,000m)

2.2.1 12-Slot IP DSLAM

The IPD12000 and IPD12000E are fourteen [14] slot chassis; slots 1-12 are reserved for interface modules (such as the AIM24000) and slots U1 and U2 are reserved for management modules.

NOTE Although the AIM24000 can be installed in both the IPD12000 and the IPD12000E, the IPD12000 has the capability to support AIM24000 ports 1-24 only; in order to make use of all 48 ports, you must install the AIM24000 in an IPD12000E.

2.2.1.1 Select a Slot for Installation

The AIM24000 may be placed in any slot, 1-12. Remove the blank plate from the chosen slot by turning the fastening screws counter-clockwise with a screwdriver and then gently sliding the blank plate out of the chassis.

12-SLOT IP DSLAM

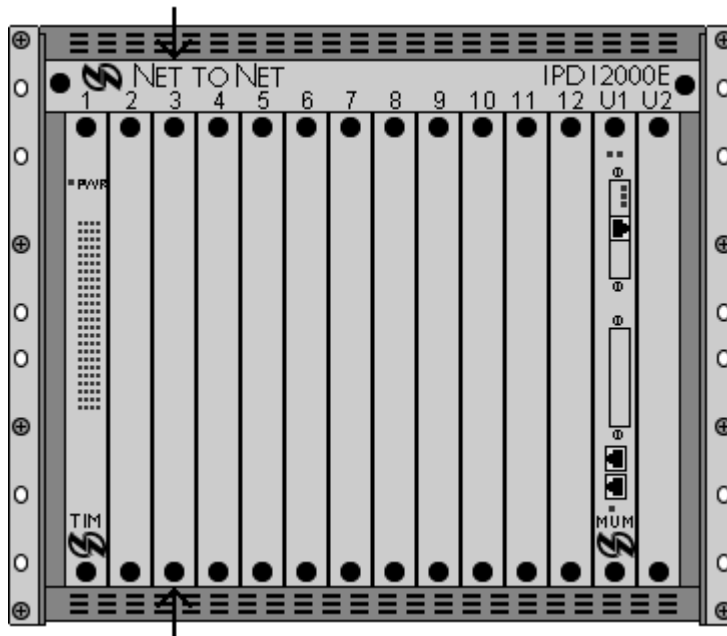

Blankplate Fastening Screws

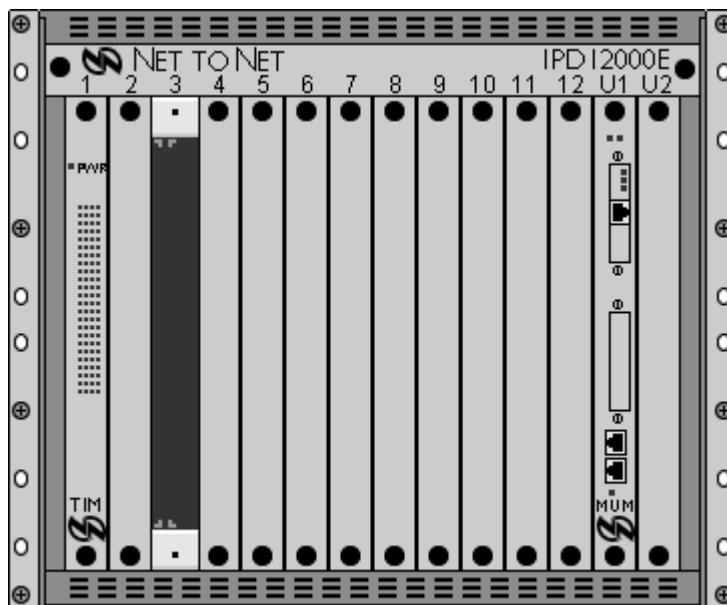

Empty Interface Module Slot

CAUTION If a blank plate is removed from slot 1-12 on Net to Net's IPD12000 or IPD12000E, it must be replaced with an interface module. DO NOT OPERATE YOUR IP DSLAM WITH AN EMPTY SLOT.

2.2.1.2 Align the AIM24000 with the Slot Module Guides

With the AIM24000 Printed Circuit Board (PCB) facing RIGHT and the AIM24000 model name, and Net to Net logo, on the LOWER edge of the faceplate, align the upper and lower edges of the PCB with the slot module guides.

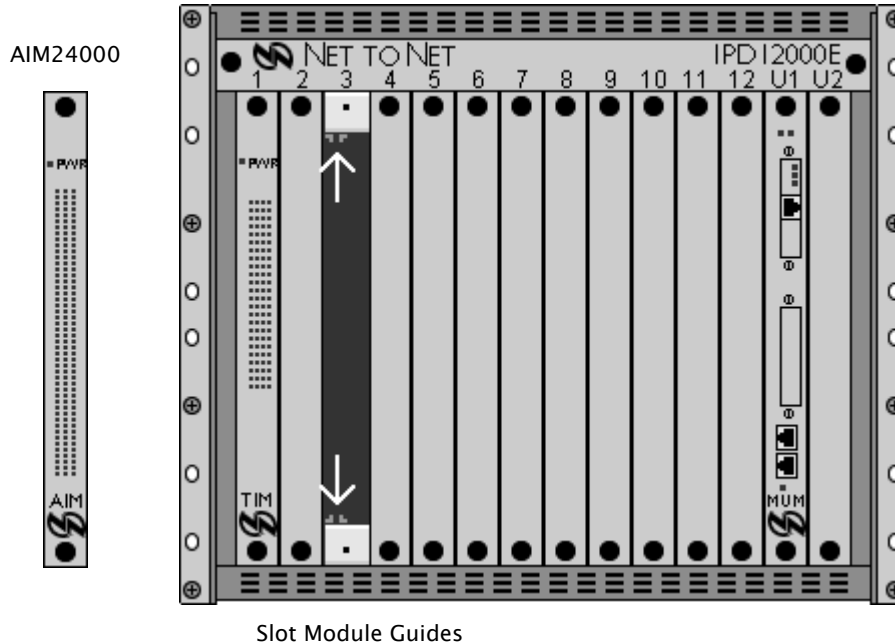

2.2.1.3 Slide the AIM24000 Firmly into the Chassis DO NOT USE EXCESS FORCE.

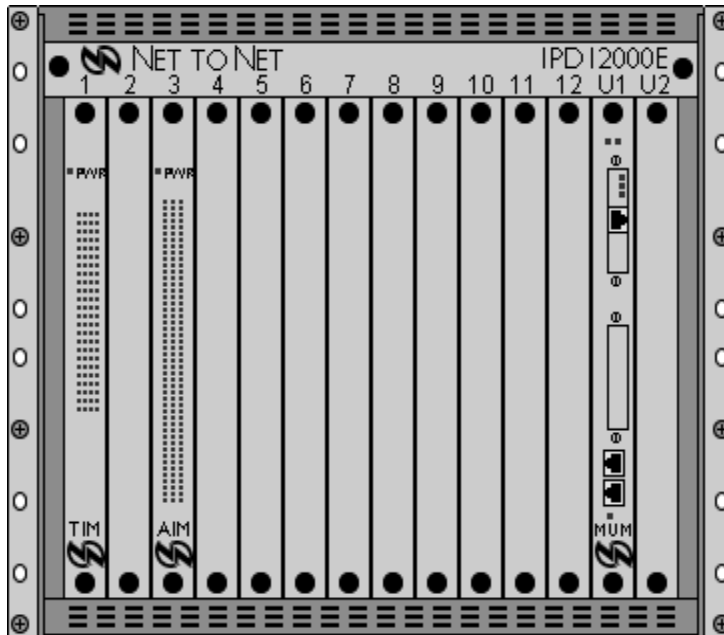

2.2.1.4 Secure the AIM24000 in the Chassis

Tighten the fastening screws on the AIM24000 faceplate by turning them clockwise with a screwdriver, just until snug. DO NOT OVER-TIGHTEN the fastening screws.

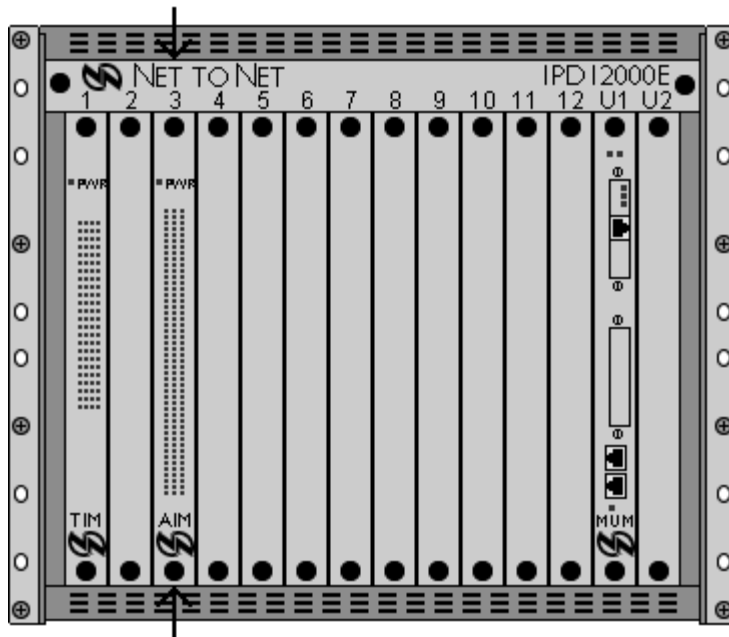

AIM24000 Fastening Screws

FASTENING SCREW



(turn clockwise to tighten)

2.2.2 4-Slot IP DSLAM

The IPD4000 and IPD4000E are five [5] slot chassis, slots 1-4 are reserved for interface modules (such as the AIM24000) and slot U1 is reserved for a management module.

NOTE Although the AIM24000 can be installed in both the IPD4000 and the IPD4000E, the IPD4000 has the capability to support AIM24000 ports 1-24 only; in order to make use of all 48 ports, you must install the AIM24000 in an IPD4000E.

2.2.2.1 Select a Slot for Installation

The AIM24000 may be placed in any slot, 1-4. Remove the blank plate from the chosen slot by turning the fastening screws counter-clockwise with a Phillips screwdriver and then gently sliding the blank plate out of the chassis

4-SLOT IP DSLAM

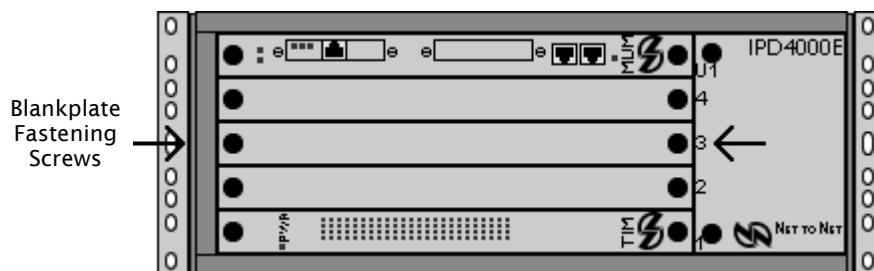

FASTENING SCREW



(turn counter-clockwise to loosen)

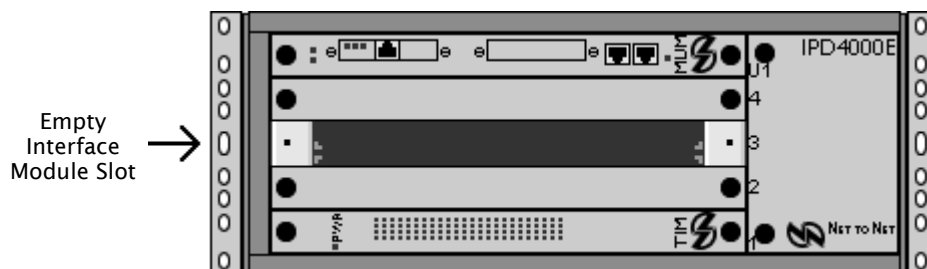

CAUTION If a blank plate is removed from slot 1-4 on Net to Net's IPD4000 or IPD4000E, it must be replaced with an interface module. DO NOT OPERATE YOUR IP DSLAM WITH AN EMPTY SLOT.

2.2.2.2 Align the AIM24000 with the Slot Module Guides

With the AIM24000 Printed Circuit Board (PCB) facing UP and the AIM24000 faceplate model name, and Net to Net logo, on the RIGHT, align the edges of the PCB with the slot module guides on both sides.

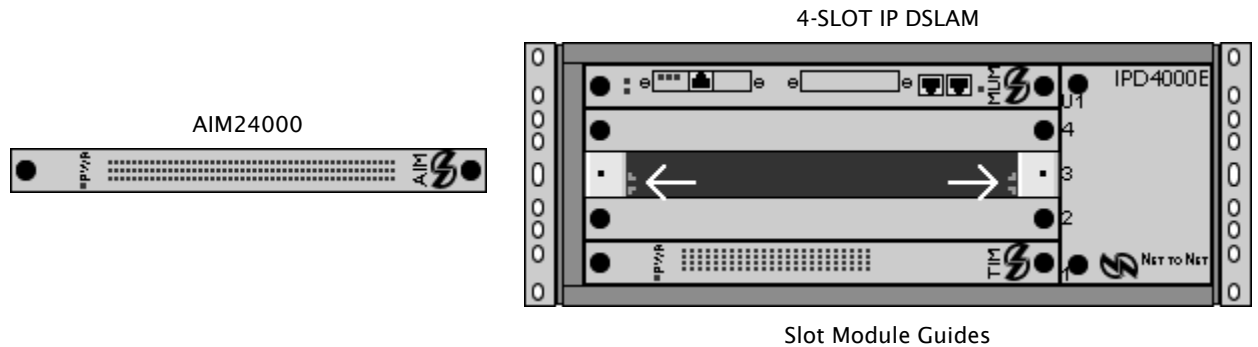

2.2.2.3 Slide the AIM24000 Firmly into the Chassis

DO NOT USE EXCESS FORCE.

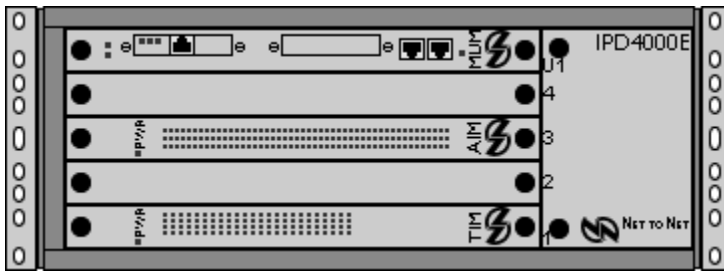

2.2.2.4 Secure the AIM24000 in the Chassis

Tighten the fastening screws on the AIM24000 faceplate by turning them clockwise with a Phillips screwdriver, just until snug. DO NOT OVER-TIGHTEN the fastening screws.

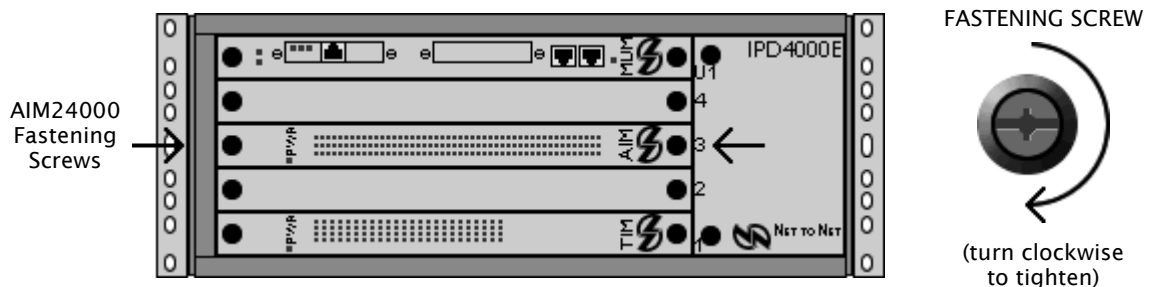

2.3 Verify Power Reception

NOTE If you have not already powered up your IP DSLAM, do so now. Refer to your IP DSLAM Installation Instructions at <http://www.nettonet.com/support/docs/#i> for further instruction.

POWER SPECIFICATIONS

-48V DC (supplied by the host IP DSLAM)
1.6 Amps

The PWR (power) LED on the AIM24000 faceplate will illuminate solid green to indicate the AIM24000 is receiving power.



2.4 Connect Your ADSL Cable(s)

2.4.1 Local Connection

2.4.1.1 12-Slot IP DSLAM

2.4.1.1.1 Identify the Correct RJ21 Port(s) for Connection

Subscriber lines must be connected according to the IP DSLAM slot in which the AIM24000 was installed. Interface module slots 1-12 run from left to right when you are facing the front of the chassis; the corresponding RJ21 ports are directly behind each slot on the back of the chassis (1-12, right to left, when you are facing the back of the chassis). Each interface module slot on Net to Net's IPD12000E has two [2] corresponding female RJ21 connectors: the bottom row of connectors (A) provides the ADSL connection for AIM24000 ports 1-24 and the top row of RJ21 connectors (B) provides the ADSL connection for ports 25-48.

NOTE Net to Net's IPD12000 has only one female RJ21 connector for each interface module slot. These connectors support ports 1-24 (only) on your AIM24000; ports 25-48 cannot be connected in an IPD12000.

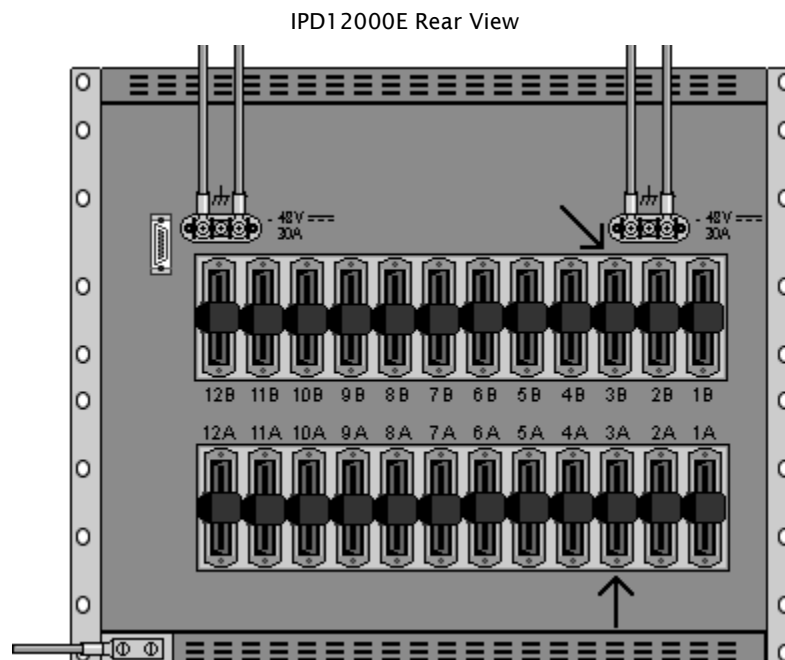

In previous illustrations, the AIM24000 was installed in Slot 3 of an IPD12000E and, as such, the ADSL cable would require connection to the following RJ21 ports:

Female RJ21 Connector 3B
for AIM24000 ports 25-48

Female RJ21 Connector 3A
for AIM24000 ports 1-24

2.4.1.1.2 Connect Your ADSL Cable(s)

NOTE No configuration is necessary for the AIM24000 to operate at default settings. However, if you wish to run your subscriber connections at settings other than the factory defaults, Net to Net recommends configuring the AIM24000 prior to ADSL connection. Refer to Section 4.0 for further information.

2.4.1.1.2.1 Detach the Velcro Strap

Detach the Velcro Strap from the female RJ21 connector port: lift the Velcro tab on the left and pull the strap open towards the right, leaving it looped under the right side of the connector frame.

FEMALE RJ21 CONNECTOR PORT

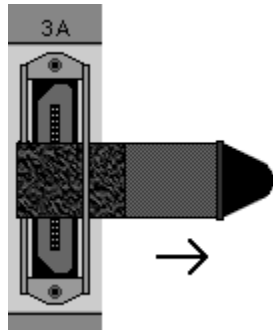

2.4.1.1.2.2 Position the RJ21 Connector

Slide the male RJ21 connector of your ADSL cable underneath the Velcro, from the bottom, and press it firmly into the female RJ21 connector port on the chassis.

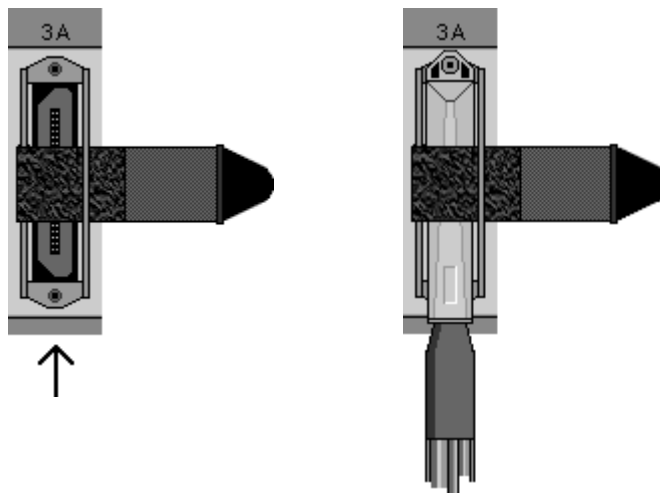

MALE RJ21 CONNECTOR OF YOUR ADSL CABLE

2.4.1.1.3 Secure the Cable(s)

Pull the Velcro strap to the right, making sure that it is snug against the connector, then pull the strap back towards the left, such that the Velcro layers stick to one another across the top of the connector. Tuck the tab at the end of the strap down to the left of the connector frame so that it is out of the way of other connections. Screw the top of the RJ21 cable connector into the jack screw at the top of the RJ21 connector frame on the chassis.

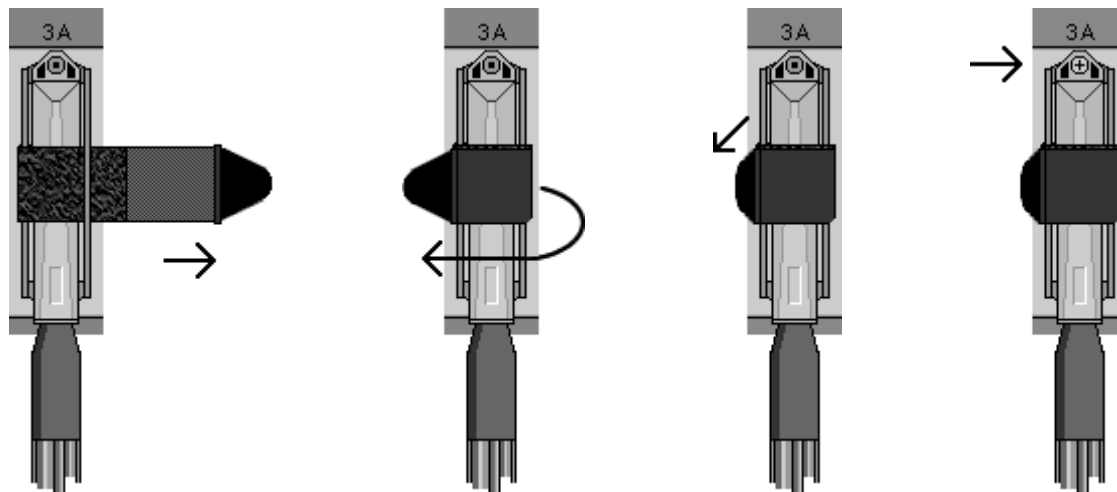

NOTE If you are using a 120 or 180 degree cable, both the top and the bottom of the RJ21 cable connector should be screwed to the connector frame on the chassis.

2.4.1.2 4-Slot IP DSLAM

2.4.1.2.1 Identify the Correct RJ21 Port(s) for Connection

Subscriber lines must be connected according to the IP DSLAM slot in which the AIM24000 was installed. Interface module slots 1-4 run from bottom to top on the front of the chassis; the corresponding RJ21 ports are directly behind each slot on the back of the chassis (1-4, bottom to top). Each interface module slot on Net to Net's IPD4000E has two [2] corresponding female RJ21 connectors: the connectors on the left (A) provide the ADSL connection for AIM24000 ports 1-24 and the connectors on the right (B) provide the ADSL connection for AIM24000 ports 25-48.

NOTE Net to Net's IPD4000 has only one female RJ21 connector for each interface module slot. These connectors support ports 1-24 (only) on your AIM24000; ports 25-48 cannot be connected in an IPD4000.

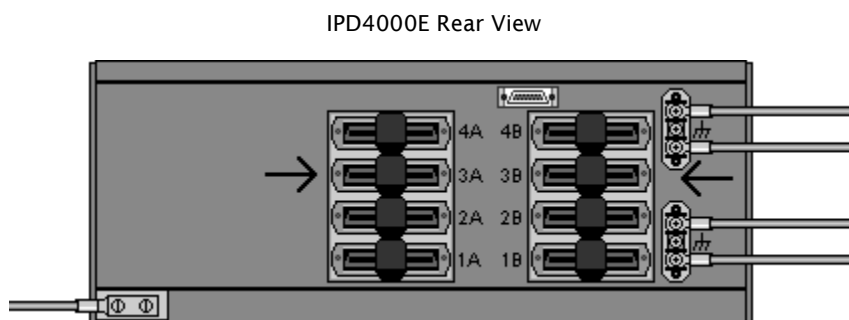

In previous illustrations, the AIM24000 was installed in Slot 3 of an IPD4000E and, as such, the ADSL cable would require connection to the following RJ21 ports:

Female RJ21 Connector 3A for AIM24000 ports 1-24

Female RJ21 Connector 3B for AIM24000 ports 25-48

2.4.1.2.2 Connect Your ADSL Cable(s)

NOTE No configuration is necessary for the AIM24000 to operate at default settings. However, if you wish to run your subscriber connections at settings other than the factory defaults, Net to Net recommends configuring the AIM24000 prior to connection. Refer to Section 4.0 for further information.

2.4.1.2.2.1 Detach the Velcro Strap

Detach the Velcro Strap from the female RJ21 connector port: lift the Velcro tab from the bottom and pull the strap open, towards the top

of the chassis, leaving it looped under the top side of the connector frame.

FEMALE RJ21 CONNECTOR PORT

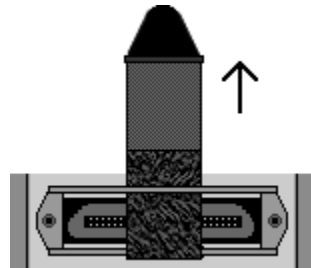

2.4.1.2.2.2 Position the RJ21 Connector

Slide the male RJ21 connector of your ADSL cable underneath the Velcro, from the left, and press it firmly into the female RJ21 connector port on the chassis.

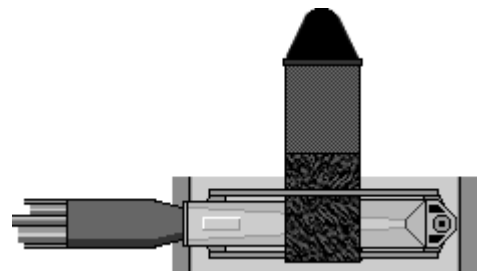
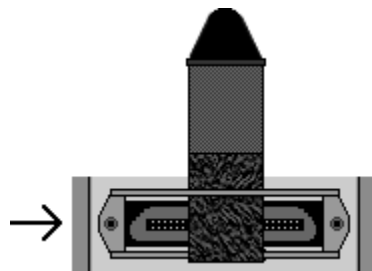

MALE RJ21 CONNECTOR OF YOUR ADSL CABLE

2.4.1.2.3 Secure the Cable(s)

Pull the Velcro strap upward, making sure that it is snug against the connector, then pull the strap back down, such that the Velcro layers stick to one another across the top of the connector. Tuck the tab at the end of the strap down between the connector frames so that it is out of the way of other connections and then screw the right side of the RJ21 cable connector into the jack screw on the right side of the RJ21 connector frame on the chassis.

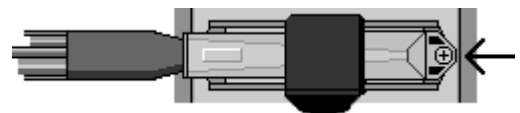
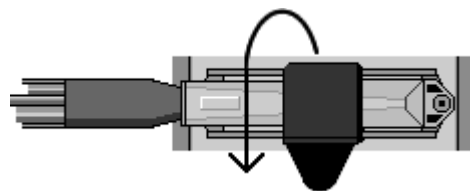
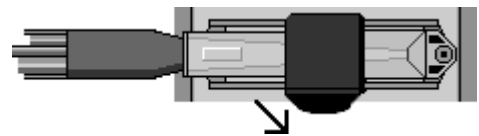
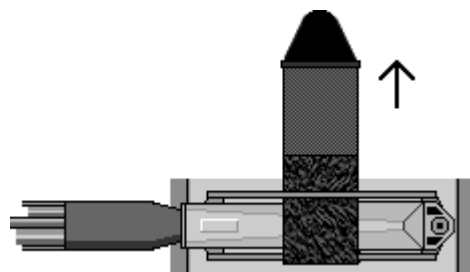

NOTE If you are using a 120 or 180 degree cable, both the left and right sides of the RJ21 cable connector should be screwed to the connector frame on the chassis.

2.4.2 Remote Connection

A single line connection can be established between any port on the AIM24000 and any compatible G.lite, ADSL, ADSL2 or ADSL2+ modem.

2.4.3 ADSL RJ21 Pinout

PORT	PIN	
	RING	TIP
1	1	26
2	2	27
3	3	28
4	4	29
5	5	30
6	6	31
7	7	32
8	8	33
9	9	34
10	10	35
11	11	36
12	12	37
13	13	38
14	14	39
15	15	40
16	16	41
17	17	42
18	18	43
19	19	44
20	20	45
21	21	46
22	22	47
23	23	48
24	24	49

(Pins 25 and 50 are not used)

AIM24000-48 ADSL FEMALE RJ21 CONNECTOR PORT

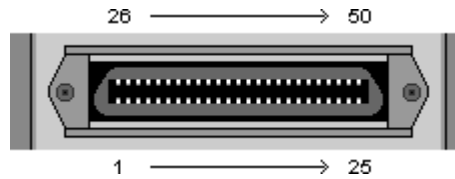

ADSL CABLE MALE RJ21 CONNECTOR

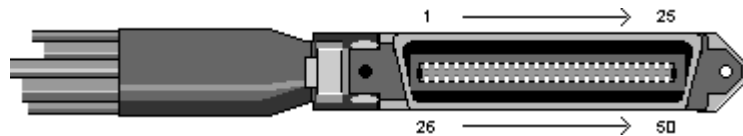

2.5 Verify the ADSL Connection(s)

The LK (Link) LED for each port being connected to a remote modem will illuminate solid green to indicate a connection has been established. Link up time between the AIM24000 and remote modems can vary from one to five minutes depending on the quality, gauge and distance of the copper cable pair(s) being used.

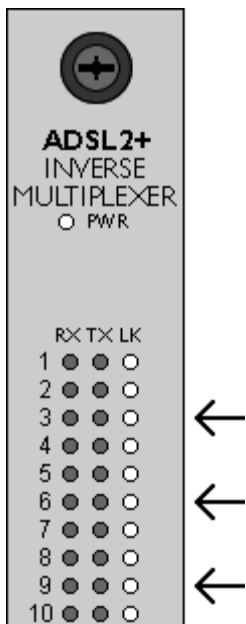

3.0 ADSL Parameters

3.1 Default Configurations

No configuration is necessary for the AIM24000 to operate at default settings.

PARAMETER	DEFAULT
Standard Mode	Multimode
Port Mode	Adaptive
Upstream Speed	n/a (Adaptive Port Mode)
Downstream Speed	n/a (Adaptive Port Mode)
IP Range 1	0.0.0.0 - 255.255.255.255
IP Range 2-4	0.0.0.0 - 0.0.0.0
VLAN	0 - 0
Backbone-VLAN	0
VLAN Priority	0
Protocol	All
Flood	Uplink
Frame Type	1483LLC
VPI/VCI Detect	On
Virtual Path Identifier (VPI)	0
Virtual Channel Identifier (VCI)	35

3.2 Parameter Definitions

3.2.1 Circuit ID

Circuit Identification (ID) is a unique and searchable 15-character, alpha-numeric, user-defined identifier used to label each port. If the Circuit ID entered is longer than

15 characters, it will automatically truncate to 15. Typically, service providers use a corresponding Customer # or Circuit ID # from their Operations Support System (OSS) in order to facilitate troubleshooting.

NOTE Net to Net's Circuit ID field is not yet integrated with any OSS system and is currently for reference only.

3.2.2 Standard Mode

Default: Multimode

3.2.2.1 Multimode

An AIM24000 port set to multimode detects and matches the standard mode of the remote ADSL modem to which it's connected.

3.2.2.2 Full Rate ADSL2

An AIM24000 port that is operating in full rate ADSL2 mode and utilizing a single line for both phone and data, requires an in-line splitter at both ends of the ADSL2 connection.

NOTE The Full Rate ADSL2 options (G.DMT.BIS, G.DMT.BISplus and READSL2) are not yet available for configuration via CLI or SNMP; these standard modes are currently configurable via NMS only.

3.2.2.2.1 G.DMT.BIS

G.DMT.BIS is ADSL2 technology in compliance with the standards of the International Telecommunications Union Telecommunication Standardization Sector (ITU-T) Recommendation G.992.3 which specifies a downstream frequency range of 1100 kHz.

3.2.2.2.2 G.DMT.BISplus

G.DMT.BISplus is ADSL2+ technology in compliance with the standards of ITU-T Recommendation G.992.5 which specifies a downstream frequency range of 2200 kHz.

3.2.2.2.3 READSL2

Reach Expanded ADSL2 is ADSL2 technology in compliance with the standards of ITU-T Recommendation G.992.3 in Annex L format.

3.2.2.3 Full Rate ADSL

An AIM24000 port that is operating in full rate ADSL mode and utilizing a single line for both phone and data, requires an in-line splitter at both ends of the ADSL connection.

3.2.2.3.1 G.DMT

G.DMT is ADSL technology in compliance with the standards of ITU-T Recommendation G.992.1. The AIM24000 exceeds the ITU-T G.992.1 minimum requirements of 640 kbps upstream and 6,000 kbps downstream speeds in G.DMT mode.

3.2.2.3.2 T1.413

T1.413 is ADSL technology in compliance with the standards of the American National Standards Institute (ANSI) Standard T1.413.

3.2.2.3.3 Alcatel

Alcatel is ADSL technology and Alcatel ADSL modem compatible.

3.2.2.4 G.lite

G.lite is ADSL technology in compliance with the standards of ITU-T Recommendation G.992.2. The AIM24000 meets the ITU-T Recommendation G992.2 minimum requirements of 512 kbps upstream and 5,136 kbps downstream speeds in G.lite mode. An AIM24000 port that is operating in G.lite mode and utilizing a single line for both phone and data, requires an in-line splitter at the local end, and a microfilter at the remote end, of the ADSL connection.

3.2.3 Port Mode

Default: Adaptive

3.2.3.1 Adaptive

An AIM24000 port set to port mode *adaptive* will automatically train up to the best possible speed supported by the AIM24000, the ADSL modem at the remote end, and the copper cable pair connecting the two.

3.2.3.2 Fixed

An AIM24000 port set to port mode *fixed* will maintain constant upstream and downstream bandwidths as specified by the user.

3.2.3.3 Fixed Adaptive

An AIM24000 port set to port mode *fixed adaptive* will automatically train up to the best possible speed supported by the AIM24000, the ADSL modem at the remote end, and the copper cable pair connecting the two, within the confines of user-specified maximum upstream and downstream bandwidths.

3.2.3.4 Off

An AIM24000 port set to port mode *off* has been administratively turned off.

3.2.4 Bandwidth and Distance

The default bandwidth for AIM24000 ADSL connections is *Adaptive* as defined in section 3.2.3.1. The eventual outcome could be any combination of existing possible upstream and downstream bandwidths, and may or may not be reflected in the following tables. For AIM24000 ports configured at *Fixed* or *Fixed Adaptive* port modes, bandwidth parameters must be manually specified.

The distance capabilities listed in the following tables assume the use of 26 American Wire Gauge (AWG) cable; connections made with cable of a greater gauge (e.g., 24 AWG) will link up at greater distances. The AIM24000 may not link up if the cable is in poor condition or if the cable distance is greater than a particular bandwidth will support. Remote ADSL modems determine bandwidth through their communication with the AIM24000.

NOTE The following tables show maximum possible distances for various sample combinations of upstream and downstream bandwidths over a typical ADSL line. Data given is meant solely as a guide in determining achievable distances at various bandwidth settings; these tables are NOT COMPREHENSIVE. The many possible combinations of upstream and downstream bandwidths, along with attainable corresponding distances for each combination, are far more numerous than that which is feasible to list here.

3.2.4.1 Full Rate ADSL2

3.2.4.1.1 G.DMT.BIS (ADSL2)

An AIM24000 port in ADSL2 mode is capable of reaching downstream speeds of up to 11,937 kbps under optimal conditions.

DISTANCE		HIGH INTERLEAVE		LOW INTERLEAVE	
		upstream	downstream	upstream	downstream
feet	meters	kbps	kbps	kbps	kbps
8,000	2,438	1,085	10,104	1,154	10,069
9,000	2,743	1,085	9,681	1,154	9,525
10,000	3,048	1,085	8,544	1,150	8,305
11,000	3,353	1,085	7,179	1,146	6,957
12,000	3,658	1,085	5,721	1,099	5,428
13,000	3,962	992	4,381	996	4,044
14,000	4,267	896	3,375	892	3,357
15,000	4,572	795	2,535	775	2,521
16,000	4,877	703	1,826	692	1,820
17,000	5,182	611	1,349	590	1,293
18,000	5,486	508	847	495	861
19,000	5,791	405	468	397	468

3.2.4.1.2 G.DMT.BISplus (ADSL2+)

An AIM24000 port in ADSL2+ mode is capable of reaching downstream speeds of up to 21,790 kbps under optimal circumstances.

DISTANCE		HIGH INTERLEAVE		LOW INTERLEAVE	
		upstream	downstream	upstream	downstream
feet	meters	kbps	kbps	kbps	kbps
8,000	2,438	1,085	13,036	1,126	12,589
9,000	2,743	1,067	10,718	1,087	10,385
10,000	3,048	1,085	8,335	1,130	8,057
11,000	3,353	1,085	6,692	1,075	6,305
12,000	3,658	1,085	5,020	1,063	4,606
13,000	3,962	1,015	3,820	1,015	3,772
14,000	4,267	925	2,856	924	2,880
15,000	4,572	821	2,135	830	2,131
16,000	4,877	740	1,513	731	1,464
17,000	5,182	659	985	613	1,000
18,000	5,486	586	637	570	641
19,000	5,791	361	379	344	354

3.2.4.1.3 READSL2 (Reach Expanded ADSL2)

DISTANCE		HIGH INTERLEAVE		LOW INTERLEAVE	
		upstream	downstream	upstream	downstream
feet	meters	kbps	kbps	kbps	kbps
16,000	4,877	859	2,023	845	2,035
17,000	5,182	755	1,483	759	1,468
18,000	5,486	663	1,085	657	1,059
19,000	5,791	567	667	558	684

3.2.4.2 Full Rate ADSL

An AIM24000 port in G.DMT, T1.413 or Alcatel mode is capable of reaching downstream speeds of up to 11,936 kbps under optimal circumstances.

DISTANCE		INTERLEAVE LATENCY		FAST LATENCY	
		upstream	downstream	upstream	downstream
feet	meters	kbps	kbps	kbps	kbps
8,000	2,438	1,024	10,400	1,024	10,464
9,000	2,743	1,024	9,568	1,024	9,376
10,000	3,048	1,024	8,096	960	8,224
11,000	3,353	1,024	6,688	960	6,592
12,000	3,658	992	5,216	864	5,248
13,000	3,962	896	3,808	768	3,936
14,000	4,267	896	3,296	768	2,944
15,000	4,572	768	2,464	640	2,144
16,000	4,877	512	1,728	544	1,408
17,000	5,182	544	1,216	448	1,024
18,000	5,486	448	864	256	640
19,000	5,791	352	512	288	384

3.2.4.3 G.lite

DISTANCE		UPSTREAM	DOWNSTREAM
feet	meters	kbps	
15,000	4,572	512	1,536
16,000	4,877	416	1,536
17,000	5,182	288	1,056
18,000	5,486	192	768
19,000	5,791	128	448

3.2.5 IP Range

IP Range 1 Default: 0.0.0.0 - 225.255.255.255

IP Range 2-4 Default: 0.0.0.0 - 0.0.0.0

IP Range filtering is user-defined via configurable starting and ending IP addresses that specify an acceptable range of source IP addresses for incoming packets. Up to four [4] IP ranges may be configured per port in NMS, up to two [2] IP ranges may be configured per port via CLI or SNMP.

3.2.5.1 Single IP Address

Starting IP Address = Ending IP Address

An AIM24000 port configured with a single source IP address will only allow packets with that specific IP address to traverse the port.

3.2.5.2 IP Address Range

Starting IP Address < Ending IP Address

An AIM24000 port configured with a source IP address range will allow packets having an IP address within the specified range to traverse the port.

3.2.5.3 Full IP Address Range

Starting IP Address = 0.0.0.0

Ending IP Address = 255.255.255.255

An AIM24000 port configured with the full range of source IP addresses will allow packets with ANY source IP address to traverse the port.

3.2.6 VLAN

Default: 0 - 0 (off)

The AIM24000 complies with the Institute of Electrical and Electronics Engineers, Inc. (IEEE) 802.1Q Virtual Bridge Local Area Networks Standard. Virtual Local Area Network (VLAN) start and end tags indicate the 802.1Q VLAN tag range to be supported for each port. VLAN tags are the primary identifiers unless used in conjunction with a Backbone-VLAN. Up to 10 Virtual Local Area Network (VLAN) ranges may be specified per port. The application of a port's VLAN configurations on the traffic attempting to traverse that port depends upon the IP DSLAM management module model and firmware revision, as well as the management platform (NMS, CLI or SNMP) that was used to set the VLAN configurations. Refer to Section 4.1.3 (NMS), Section 4.2.2.6 (CLI) and/or Section 4.3.2 (SNMP) for further VLAN configuration information and to your management module's Release Notes for revision capabilities. Configuration options for each of the 10 possible VLAN ranges includes the following:

VLAN Off: Start Tag = 0, End Tag = 0

Single VLAN: Start Tag = End Tag

VLAN Range: Start Tag < End Tag

3.2.7 Backbone-VLAN

Default: 0 (disabled)

Used in conjunction with standard VLAN tags, a single Backbone-VLAN tag will become the primary identifier, allowing a router with backbone capabilities to make

smarter decisions in directing traffic to the proper network. Once a packet has reached the proper network, its standard VLAN tags will direct it to the appropriate port.

NOTE A Backbone-VLAN tag cannot be used independently; standard VLAN tags must also be configured. Additionally, the DSLAM uplink connection must run through a router in order for a Backbone-VLAN tag to function.

3.2.8 VLAN Priority

Default: 0 (no priority)

In compliance with the IEEE 802.1p Standard (a subset of 802.1Q), there are eight levels of prioritization designated numerically within a range of 0 to 7. The application of a port's VLAN Priority configuration on the traffic attempting to traverse that port depends upon the IP DSLAM management module model and firmware revision, as well as the management platform (NMS, CLI or SNMP) that was used to set the port's VLAN configurations. Refer to Section 4.1.3 (NMS), Section 4.2.2.8 (CLI) and/or Section 4.3.2 (SNMP) for further VLAN Priority configuration information and to your management module's Release Notes for revision capabilities.

0 = no priority

1 = the lowest priority

7 = the highest priority

3.2.9 Protocol

Default: All

Traffic protocol is indicated by a 2-byte (hexidecimal) Ethertype code in packet headers.

3.2.9.1 All

An AIM24000 port configured with Protocol *All* will allow packets with all Ethertype protocols to traverse the port.

3.2.9.2 Select

An AIM24000 port configured with Protocol *Select* allows specification of up to four [4] Ethertype protocols; only packets with the specified Ethertype(s) will be allowed to traverse the port.

NOTE Not all IP DSLAM management modules provide the Protocol *Select* option in NMS, neither is the *Select* option available via CLI or SNMP. In these instances you will be required to choose between *All* or *IP*, where *IP* indicates that only Transmission Control Protocol (TCP), Internet Protocol (IP) and Address Resolution Protocol (ARP) traffic will be allowed to traverse the port.

3.2.10 Flood

Default: Uplink

Flood refers to the method in which interface modules handle unknown unicasts (traffic directed to a single MAC Address), unknown broadcasts (traffic directed to all MAC Addresses) and unknown multicasts (traffic directed to multiple MAC Addresses) for each port.

3.2.10.1 Uplink

An AIM24000 port configured with Flood *Uplink* will flood all unknown unicast, broadcast and multicast traffic to the IP DSLAM uplink ports, thus preventing communication between interface ports without the intervention of an upstream device such as a router. If communication between interface ports is desired, the upstream device must be properly configured to allow it.

3.2.10.2 VLAN

An AIM24000 port configured with Flood *VLAN* will flood all unknown unicast, broadcast and multicast traffic to the IP DSLAM interface ports (within the sender's VLAN range) in addition to the IP DSLAM uplink ports.

3.2.11 Frame Type

Default: 1438LLC

Frame type is the ADSL data encapsulation method for carrying traffic over an ATM network as defined by the Internet Engineering Task Force (IETF) Request for Comment (RFC) 1483.

3.2.11.1 1438LLC

An AIM24000 port configured with Logical Link Control (LLC) encapsulation multiplexes multiple protocols over a single ATM Virtual Circuit by way of the protocol-identifying frame header *1438LLC*.

3.2.11.2 1483VCM

An AIM24000 port configured with Virtual Circuit Multiplexing (VCM) creates a separate ATM Virtual Circuit connection for each protocol type, without additional encapsulation, by way of the protocol-identifying frame header *1438VCM*.

3.2.12 VPI/VCI Detect

Default: On

ADSL data travels by way of Asynchronous Transfer Mode (ATM) cells across Permanent Virtual Circuits (PVCs). Each PVC consists of one Virtual Channel across one Virtual Path as identified by a Virtual Channel Identifier (VCI) and a Virtual Path Identifier (VPI). A VPI is designated by an 8-bit field in ATM cell headers and a VCI is designated by a 16-bit field in ATM cell headers. The AIM24000 supports one PVC per port.

3.2.12.1 On

An AIM24000 port with VPI/VCI Detect *on* will automatically "snoop" the line to determine the VPI and VCI settings of the remote ADSL modem to which it's connected and set itself accordingly. If no ATM cells are detected (at any VPI/VCI setting), the port will default to VPI 0 and VCI 35. Thereafter, once it does detect ATM cells from the remote ADSL modem, it will reconfigure VPI and VCI to the same settings at which the ATM cells from the remote ADSL modem were detected.

3.2.12.2 Off

An AIM24000 port with VPI/VCI Detect *off* will default to VPI 0 and VCI 35 UNLESS the port was previously set at VPI/VCI Detect *on* and had already detected the VPI and VCI settings of the remote ADSL modem. In this case,

turning the VPI/VCI Detect function *off* will lock in the previously detected settings until, or unless, the VPI and VCI values are altered manually.

3.2.12.3 Manual

If you wish to set VPI and VCI values manually, VPI/VCI Detect should be set to *off* BEFORE the VPI and VCI values are entered. When manually configuring VPI and VCI, each port on the AIM24000 must be assigned the same VPI and VCI values as the remote ADSL modem to which that port is connected in order for the units to communicate.

4.0 AIM24000 Management

All parameters on the AIM24000 are software selectable. Dependent upon the management module installed in your IP DSLAM, the AIM24000 can be configured via Command Line Interface (CLI), Simple Network Management Protocol (SNMP) and/or Net to Net Technologies' web-based Network Management System (NMS).

4.1 Via NMS

NMS is an embedded web server that resides within the firmware of IP DSLAM management modules. This web server maintains statistical and configurational data for the AIM24000.

NOTE If your IP DSLAM is newly installed and has not yet been initialized, you must configure the IP Address, Subnet Mask and Gateway before you will be able to access data or complete any other configurations. Refer to Net to Net's NMS Management User Guide at <http://www.nettonet.com/support/docs/210-0000048> for instructions.

4.1.1 Log In

Open an NMS window and log on. You must log on as a Superuser in order to configure the AIM24000.



NOTE Net to Net's default Superuser username is "superuser" and the default Superuser password is "Password" (both are case sensitive).

4.1.2 Circuit Configuration

Click on the AIM24000 port LED corresponding to the port you wish to configure, as depicted on the DSLAM image in the NMS main window; clicking on a port LED will open the Circuit Configuration window for that port.

IP DSLAM Network Management System v2.1 - Microsoft Internet Explorer

NET TO NET TECHNOLOGIES

sysName MUM2000-2 sysUpTime (ddd hh mm:ss) 00 03 04 54

System Configuration

- Management Config
- Advanced Config
- HTTP Password
- SNMP Config
- SNMP Community
- Global Set

System Utilities

- Circuit Summary
- Circuit Search
- DSLAM Users
- Diagnostics
- Show Help
- Refresh Screen

Notes:

IP DSL Access Multiplexer - IPD12000 Active MUM in slot 13

submit Messages

Circuit Configuration - Microsoft Internet Explorer

Circuit Config DSCP & IP Rules MAC Rules VLAN Rules Port Statistics Port Copy SNR Advanced Config

Slot	Port	Circuit Identification	Device Type	Revision
2	10		AIM24000-48	1.00.00

Circuit Configuration Settings

Port Mode Setting: Fixed Adaptive Fixed Adaptive OFF

VPI/VCI Detect Setting: ON OFF

Filter IP Address Settings:

IP Range	IP Range 1	IP Range 2
IP Range 1	0.0.0.0	255.255.255.255
IP Range 2	0.0.0.0	0.0.0.0
IP Range 3	0.0.0.0	0.0.0.0
IP Range 4	0.0.0.0	0.0.0.0

Protocol Setting: All Select 0000 0000 0000 0000

Note: enter hex value, eg. 0800,00fe

DHCP Option 82 Setting: Enabled Disabled Identifying String: IPAddress:MI8II

Layer 2 Port Filter Settings: Layer 2 Port Filter Settings

Note: If port is loop bonded, only configure the lowest numbered port in the group.

MAC	MAC 1	MAC 2	MAC 3
MAC 1	00:00:00:00:00:00		
MAC 2	00:00:00:00:00:00		
MAC 3	00:00:00:00:00:00		

Unlimited # of MACs - or - Define # of MACs: 0

*Check the box to activate the port filters.

VPI VCI Frame Type Standard Mode

0	0	1483LLC	MULTIMODE
---	---	---------	-----------

submit

Port Status: Link Adaptive 1024 Kbps Up, 10720 Kbps Dn Actual Std Mode: G_DMT Actual VPI/VCI: 0/35 Actual SNR[up/dn]: 6dB/6dB Delay[up/dn]: 16ms/16ms Correction[up/dn]: 1ms/1ms Interleave Depth[up/dn]: 8/64 Las Update: 00:00:00:00

4.1.2.1 Verify Port Information

Ensure that the Slot and Port number specified correspond to that of the port you wish to configure. Device Type should specify AIM24000-48 or AIM24000-48B and the Revision should list the firmware version of the AIM24000. If you wish to configure a different port from that which is listed, use the Slot and Port pull-down menus to specify another port location.

Slot	Port	Circuit Identification	Device Type	Revision
2	10		AIM24000-48	1.00.00
1	1			
2	2			
3	3			
4	4			
5	5			
6	6			
7	7			
8	8			
9	9			
10	10			
11	11			
12	12			
	13			
	14			
	15			
	16			
	17			
	18			
	19			
	20			
	21			
	22			
	23			
	24			
	25			
	26			
	27			
	28			
	29			
	30			
	31			
	32			
	33			
	34			
	35			
	36			
	37			
	38			
	39			
	40			
	41			
	42			
	43			
	44			
	45			
	46			
	47			
	48			

4.1.2.2 Circuit Identification

User Defined: up to 15 alpha-numeric characters

Default: n/a

Slot	Port	Circuit Identification	Device Type	Revision
2	10		AIM24000-48	1.00.00

Circuit Identification
XXXXXXXXXXXXXXXXXX

4.1.2.3 Port Mode

Options: Fixed, Adaptive, Fixed Adaptive, Off

Default: Adaptive

Click to fill the circle of the configuration you wish to select.

Circuit Configuration Settings

Port Mode Setting
 Fixed Adaptive Fixed Adaptive OFF

VPI/VCI Detect Setting
 ON OFF

Filter IP Address Settings

IP Range 1	0.0.0.0	255.255.255.255
IP Range 2	0.0.0.0	0.0.0.0
IP Range 3	0.0.0.0	0.0.0.0
IP Range 4	0.0.0.0	0.0.0.0

Protocol Setting
 All Select
Note: enter hex value, eg. 0800,00fe

DHCP Option 82 Setting
 Enabled Disabled
 Identifying String:

Layer 2 Port Filter Settings
Note: If port is loop bonded, only configure the lowest numbered port in the group.
 MAC 1:
 MAC 2:
 MAC 3:
 Unlimited # of MACs
 - or -
 Define # of MACs:
*Check the box to activate the port filters.

Port Mode Setting
 Fixed Adaptive Fixed Adaptive OFF

If you select *Fixed* or *Fixed Adaptive* for the port mode, you will need to specify upstream and downstream parameters as well. Configuration fields for data rates will not appear until you *Submit* (Section 4.1.2.11) the *Fixed* or *Fixed Adaptive* port mode selection.

Port Mode Setting
 Fixed Adaptive Fixed Adaptive OFF

Circuit Configuration Settings

Port Mode Setting
 Fixed Adaptive Fixed Adaptive OFF

VPI/VCI Detect Setting
 ON OFF

Data Rate Setting
 Up: Dn:

Filter IP Address Settings

IP Range 1	0.0.0.0	255.255.255.255
IP Range 2	0.0.0.0	0.0.0.0
IP Range 3	0.0.0.0	0.0.0.0
IP Range 4	0.0.0.0	0.0.0.0

Protocol Setting
 All Select
Note: enter hex value, eg. 0800,00fe

DHCP Option 82 Setting
 Enabled Disabled
 Identifying String:

Layer 2 Port Filter Settings
Note: If port is loop bonded, only configure the lowest numbered port in the group.
 MAC 1:
 MAC 2:
 MAC 3:
 Unlimited # of MACs
 - or -
 Define # of MACs:
*Check the box to activate the port filters.

4.1.2.3.1 Fixed

Enter the desired upstream (Up) and downstream (Dn) rates (kbps) in the corresponding fields.

4.1.2.3.2 Fixed Adaptive

Enter the desired maximum boundaries, for both upstream (Up) and downstream (Dn) rates (kbps), in the corresponding fields.

Data Rate Setting	
Up <input type="text" value="1024"/>	Dn <input type="text" value="8064"/>

4.1.2.4 VPI/VCI Detect
Options: On or Off
Default: On

Click to fill the circle for either *On* or *Off*.

Circuit Configuration Settings	
Port Mode Setting	
<input type="radio"/> Fixed <input checked="" type="radio"/> Adaptive <input type="radio"/> Fixed Adaptive <input type="radio"/> OFF	
VPI/VCI Detect Setting <input checked="" type="radio"/> ON <input type="radio"/> OFF	
Filter IP Address Settings	Protocol Setting
IP Range 1: <input type="text" value="0.0.0.0"/> <input type="text" value="255.255.255.255"/> IP Range 2: <input type="text" value="0.0.0.0"/> <input type="text" value="0.0.0.0"/> IP Range 3: <input type="text" value="0.0.0.0"/> <input type="text" value="0.0.0.0"/> IP Range 4: <input type="text" value="0.0.0.0"/> <input type="text" value="0.0.0.0"/>	<input checked="" type="radio"/> All <input type="radio"/> Select <input type="text" value="0000"/> <input type="text" value="0000"/> <input type="text" value="0000"/> <input type="text" value="0000"/> <small>Note: enter hex value, eg. 0800,00fe</small>
DHCP Option 82 Setting	<input type="checkbox"/> Layer 2 Port Filter Settings
<input type="radio"/> Enabled <input type="text" value="Identifying String"/> <input checked="" type="radio"/> Disabled <input type="text" value="IPaddress.MIBII"/>	<small>Note: If port is loop bonded, only configure the lowest numbered port in the group.</small> MAC 1: <input type="text" value="00.00.00.00.00.00"/> MAC 2: <input type="text" value="00.00.00.00.00.00"/> MAC 3: <input type="text" value="00.00.00.00.00.00"/> <small>*Check the box to activate the port filters.</small>
	<input type="checkbox"/> Unlimited # of MACs - or - Define # of MACs: <input type="text" value="0"/>

VPI/VCI Detect Setting
<input checked="" type="radio"/> ON <input type="radio"/> OFF

4.1.2.4.1 Manual Configuration
VPI value range: 0 - 7
VCI value range: 0 - 255

If you wish to manually configure VPI and VCI values, you must first set VPI/VCI Detect to *Off*.

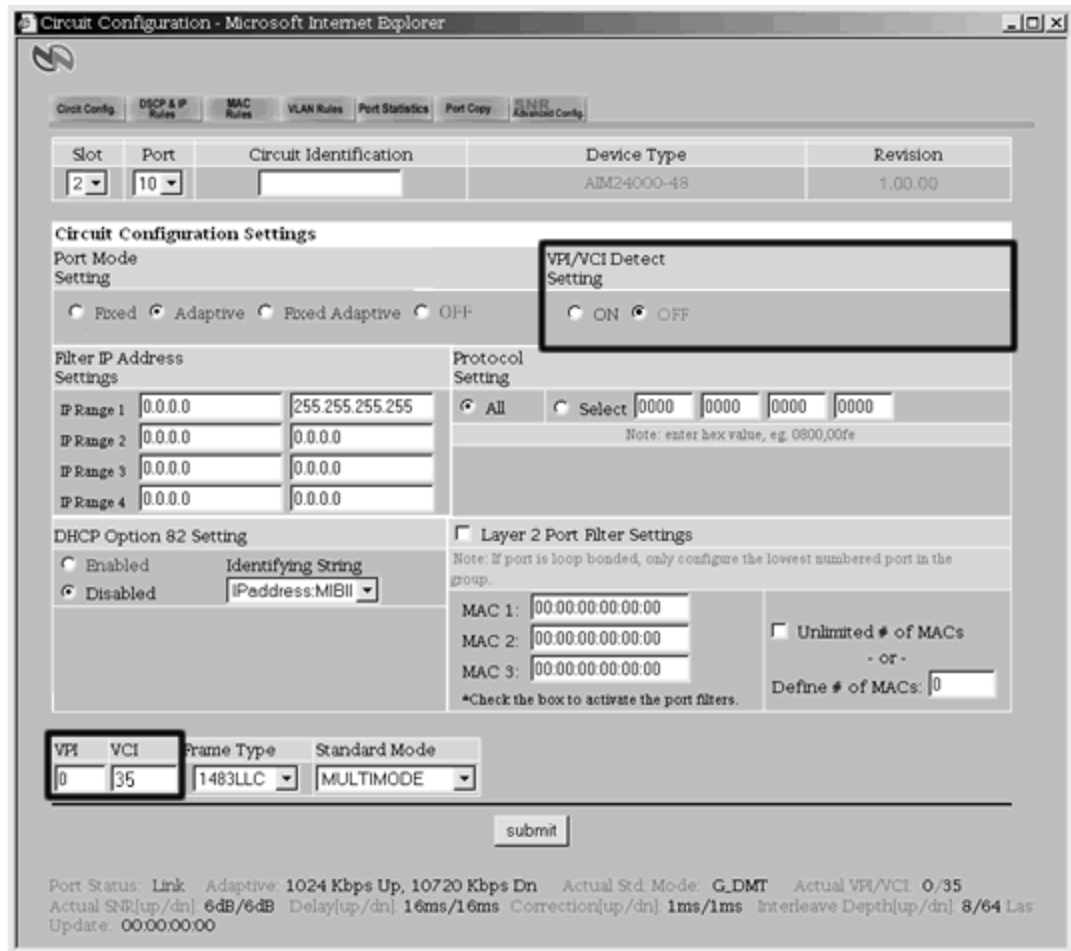

VPI	VCI
0	35

4.1.2.5 IP Range

Proper Syntax: xxx.xxx.xxx.xxx

Value Range: 0-255 for each triple-digit quadrant

Default: 0.0.0.0 - 255.255.255.255

Enter IP Range start and end parameters in the appropriate fields.

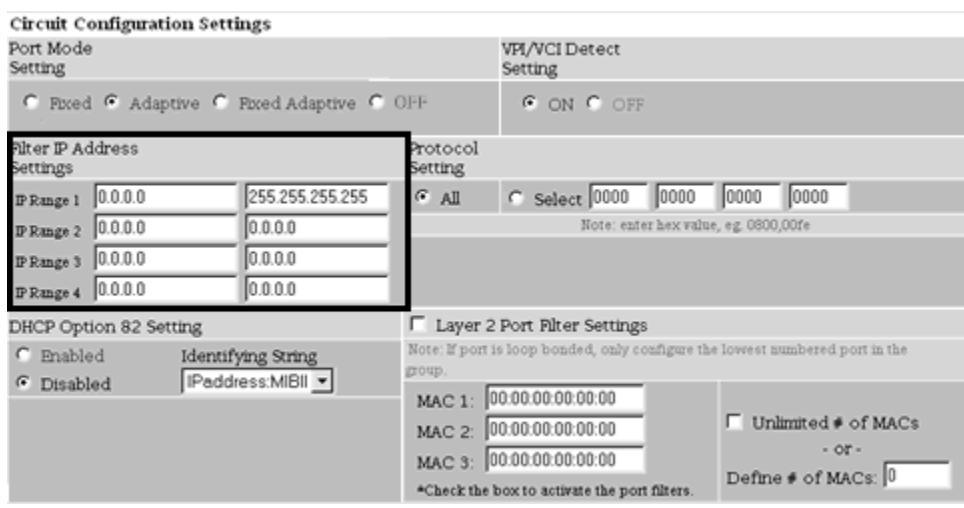

4.1.2.5.1 Single IP Address
Starting IP = Ending IP

Filter IP Address Settings		
IP Range 1	193.166.254.98	193.166.254.98
IP Range 2	0.0.0.0	0.0.0.0
IP Range 3	0.0.0.0	0.0.0.0
IP Range 4	0.0.0.0	0.0.0.0

4.1.2.5.2 IP Address Range
Starting IP < Ending IP

Filter IP Address Settings		
IP Range 1	193.166.254.98	193.166.254.254
IP Range 2	0.0.0.0	0.0.0.0
IP Range 3	0.0.0.0	0.0.0.0
IP Range 4	0.0.0.0	0.0.0.0

4.1.2.5.3 Full IP Address Range (default)
Starting IP = 0.0.0.0
Ending IP = 255.255.255.255

Filter IP Address Settings		
IP Range 1	0.0.0.0	255.255.255.255
IP Range 2	0.0.0.0	0.0.0.0
IP Range 3	0.0.0.0	0.0.0.0
IP Range 4	0.0.0.0	0.0.0.0

4.1.2.6 Protocol
Options: All or Select
Default: All

Click to fill the circle for either *All* or *Select*.

Circuit Configuration Settings													
Port Mode Setting <input type="radio"/> Fixed <input checked="" type="radio"/> Adaptive <input type="radio"/> Fixed Adaptive <input type="radio"/> Off	VPI/VCI Detect Setting <input checked="" type="radio"/> ON <input type="radio"/> OFF												
Filter IP Address Settings	Protocol Setting												
<table border="1"> <tbody> <tr> <td>IP Range 1</td> <td>0.0.0.0</td> <td>255.255.255.255</td> </tr> <tr> <td>IP Range 2</td> <td>0.0.0.0</td> <td>0.0.0.0</td> </tr> <tr> <td>IP Range 3</td> <td>0.0.0.0</td> <td>0.0.0.0</td> </tr> <tr> <td>IP Range 4</td> <td>0.0.0.0</td> <td>0.0.0.0</td> </tr> </tbody> </table>	IP Range 1	0.0.0.0	255.255.255.255	IP Range 2	0.0.0.0	0.0.0.0	IP Range 3	0.0.0.0	0.0.0.0	IP Range 4	0.0.0.0	0.0.0.0	<input checked="" type="radio"/> All <input type="radio"/> Select 0000 0000 0000 0000 <small>Note: enter hex value, eg. 0800,00fe</small>
IP Range 1	0.0.0.0	255.255.255.255											
IP Range 2	0.0.0.0	0.0.0.0											
IP Range 3	0.0.0.0	0.0.0.0											
IP Range 4	0.0.0.0	0.0.0.0											
DHCP Option 82 Setting <input type="radio"/> Enabled <input checked="" type="radio"/> Disabled Identifying String: iPaddress:MIbll	<input type="checkbox"/> Layer 2 Port Filter Settings <small>Note: If port is loop bonded, only configure the lowest numbered port in the group.</small> MAC 1: 00.00.00.00.00.00 MAC 2: 00.00.00.00.00.00 MAC 3: 00.00.00.00.00.00 <input type="checkbox"/> Unlimited # of MACs - or - Define # of MACs: 0 <small>*Check the box to activate the port filters.</small>												

Protocol Setting

All Select

Note: enter hex value, eg. 0800,00fe

Configuring AIM24000 port protocol as *Select* requires specification of desired Ethertypes (up to four [4]).

Protocol Setting

All Select

Note: enter hex value, eg. 0800,00fe

NOTE Not all IP DSLAM management modules provide the Protocol *Select* option in NMS. In these instances, you will be required to select between *All* or *IP*, where *IP* indicates that only Transmission Control Protocol (TCP), Internet Protocol (IP), and Address Resolution Protocol (ARP) traffic will be allowed to traverse the port.

4.1.2.7 DHCP Option 82
Options: Enabled or Disabled
Default: Disabled

Click to fill the circle for *Enabled* or *Disabled*.

NOTE Dynamic Host Configuration Protocol (DHCP) Option 82 is available for configuration in NMS only; it cannot yet be configured via CLI or SNMP.

DHCP Option 82 allows dynamic configuration of IP address(es) by adding an identifying string to packets (Option 82) that will enable your DHCP Server to recognize which IP DSLAM port an IP address request is coming from, thereby allowing the DHCP Server to limit the number of IP addresses assigned per port according to the DHCP Server configurations.

Circuit Configuration Settings

Port Mode Setting: Fixed Adaptive Fixed Adaptive Off

VPI/VCI Detect Setting: ON OFF

Filter IP Address Settings:

IP Range 1	<input type="text" value="0.0.0.0"/>	<input type="text" value="255.255.255.255"/>
IP Range 2	<input type="text" value="0.0.0.0"/>	<input type="text" value="0.0.0.0"/>
IP Range 3	<input type="text" value="0.0.0.0"/>	<input type="text" value="0.0.0.0"/>
IP Range 4	<input type="text" value="0.0.0.0"/>	<input type="text" value="0.0.0.0"/>

Protocol Setting: All Select

Note: enter hex value, eg. 0800,00fe

DHCP Option 82 Setting:

Enabled Identifying String:

Disabled

Layer 2 Port Filter Settings:

Note: If port is loop bonded, only configure the lowest numbered port in the group.

MAC 1:

MAC 2:

MAC 3:

Unlimited # of MACs - or - Define # of MACs:

*Check the box to activate the port filters.

4.1.2.7.1 Enabled

Option: IPAddress:MIBII or CircuitID

Default: IPAddress:MIBII

Use the pull-down menu to select the identifying string.

DHCP Option 82 Setting

Enabled Identifying String
 Disabled IPAddress:MIBII ▼
IPAddress:MIBII
Circuit ID

4.1.2.8 Layer 2 Port Filters

Options: Enabled or Disabled

Default: Disabled

NOTE Layer 2 Port Filters are available for configuration in NMS only; they cannot yet be configured via CLI or SNMP.

Circuit Configuration Settings

Port Mode Setting: Fixed Adaptive Fixed Adaptive OFF

VPI/VCI Detect Setting: ON OFF

Filter IP Address Settings:

IP Range 1	0.0.0.0	255.255.255.255
IP Range 2	0.0.0.0	0.0.0.0
IP Range 3	0.0.0.0	0.0.0.0
IP Range 4	0.0.0.0	0.0.0.0

Protocol Setting: All Select [0000] [0000] [0000] [0000]

Note: enter hex value, eg. 0800,00fe

DHCP Option 82 Setting: Enabled Disabled Identifying String: IPAddress:MIBII ▼

Layer 2 Port Filter Settings

Note: If port is loop bonded, only configure the lowest numbered port in the group.

MAC 1: 00:00:00:00:00:00
MAC 2: 00:00:00:00:00:00
MAC 3: 00:00:00:00:00:00

Unlimited # of MACs - or -
Define # of MACs: 0

*Check the box to activate the port filters.

Layer 2 Port Filter Settings

Note: If port is loop bonded, only configure the lowest numbered port in the group.

MAC 1: 00:00:00:00:00:00
MAC 2: 00:00:00:00:00:00
MAC 3: 00:00:00:00:00:00

Unlimited # of MACs - or -
Define # of MACs: 0

*Check the box to activate the port filters.

4.1.2.8.1 Static MAC Address(es)

Proper Syntax: xx:xx:xx:xx:xx:xx

Value Range: 0x00 - 0xFF (hexadecimal value) for each double-digit segment

Default: 00:00:00:00:00:00

Click the box to activate Layer 2 Port Filters, then specify up to three [3] MAC addresses. Packets containing a MAC Address that has been specified as a Layer 2 Filter for an AIM24000 port will not be allowed to enter any

OTHER interface module ports on the IP DSLAM (including other ports on the AIM24000).

→ Layer 2 Port Filter Settings

Note: If port is loop bonded, only configure the lowest numbered port in the group.

MAC 1:	<input type="text" value="00:50:CA:12:34:56"/>
MAC 2:	<input type="text" value="00:00:00:00:00:00"/>
MAC 3:	<input type="text" value="00:00:00:00:00:00"/>

Unlimited # of MACs
- or -
Define # of MACs:

*Check the box to activate the port filters.

4.1.2.8.2 Dynamic MAC Address(es)
Options: Unlimited or User-Defined
Default: 0

In addition to static MAC addresses, you may also choose to allow either an unlimited, or a defined, number of unspecified MAC addresses that will be allowed to traverse the AIM24000 port.

4.1.2.8.2.1 Unlimited
Options: Enabled or Disabled
Default: Disabled

Click the box so that a check mark appears to enable an unlimited number of MAC addresses.

Layer 2 Port Filter Settings

Note: If port is loop bonded, only configure the lowest numbered port in the group.

MAC 1:	<input type="text" value="00:50:CA:12:34:56"/>
MAC 2:	<input type="text" value="00:00:00:00:00:00"/>
MAC 3:	<input type="text" value="00:00:00:00:00:00"/>

Unlimited # of MACs
- or -
Define # of MACs:

*Check the box to activate the port filters.

NOTE If you have chosen to allow an unlimited number of MAC addresses, it is unnecessary to also configure static MAC addresses (Section 4.1.2.8.1) UNLESS you wish to tie those specific MAC addresses to the AIM24000 port such that no OTHER ports on the IP DSLAM will be allowed to receive packets containing said MAC addresses.

4.1.2.8.2.2 Defined
Options: User-Defined
Value Range: 0 - 16,384 (see note)
Default: 0

NOTE The AIM24000 supports a maximum of 16,384 MAC addresses for all 48 ports combined, which is an average of 341 MAC Addresses per port. However, the 16,384 maximum may be divided amongst the 48 ports as desired and need not be allocated equally.

Enter the number of unspecified MAC addresses you wish to be allowed to traverse the AIM24000 port.

Layer 2 Port Filter Settings

Note: If port is loop bonded, only configure the lowest numbered port in the group.

MAC 1:

MAC 2:

MAC 3:

Unlimited # of MACs
- or -
Define # of MACs:

*Check the box to activate the port filters.

4.1.2.9 Frame Type

Options: 1483LLC or 1483VCM

Default: 1483LLC

Use the pull-down menu to select either *1483LLC* or *1483VCM*.

The screenshot shows the 'Circuit Configuration' page in a Microsoft Internet Explorer browser. The 'Layer 2 Port Filter Settings' section is active, with the 'Layer 2 Port Filter Settings' checkbox checked. The 'Frame Type' dropdown menu is highlighted with a red box and set to '1483LLC'. Other visible settings include 'Port Mode Setting' (Adaptive), 'VPI/VCI Detect Setting' (ON), and 'DHCP Option 82 Setting' (Disabled). The 'submit' button is at the bottom of the configuration area.

Frame Type

1483LLC

1483VCM

4.1.2.10 Standard Mode

Options: Multimode, T1.413, G.lite, G.DMT, Alcatel, G.DMT.BIS, G.DMT.BISplus or READSL2

Default: Multimode

Use the pull-down menu to select the desired mode.

Circuit Configuration - Microsoft Internet Explorer

Circuit Config | DHCP & IP Rules | MAC Rules | VLAN Rules | Port Statistics | Port Copy | SNR Advanced Config

Slot	Port	Circuit Identification	Device Type	Revision
2	10		AIM24000-18	1.00.00

Circuit Configuration Settings

Port Mode Setting: Fixed Adaptive Fixed Adaptive OFF

VPI/VCI Detect Setting: ON OFF

Filter IP Address Settings:

IP Range	IP Range 1	IP Range 2
IP Range 1	0.0.0.0	255.255.255.255
IP Range 2	0.0.0.0	0.0.0.0
IP Range 3	0.0.0.0	0.0.0.0
IP Range 4	0.0.0.0	0.0.0.0

Protocol Setting: All Select [0000] [0000] [0000] [0000]
Note: enter hex value, eg. 0800,00fe

DHCP Option 82 Setting: Enabled Disabled
 Identifying String: [IPaddress.MIBII]

Layer 2 Port Filter Settings: Layer 2 Port Filter Settings
Note: If port is loop bonded, only configure the lowest numbered port in the group.

MAC 1:	00.00.00.00.00.00
MAC 2:	00.00.00.00.00.00
MAC 3:	00.00.00.00.00.00

Unlimited # of MACs
 - or -
 Define # of MACs: [0]
*Check the box to activate the port filters.

VPI: [0] VCI: [0] Frame Type: [1483LLC] Standard Mode: [MULTIMODE]

submit

Port Status: Link Adaptive 1024 Kbps Up, 10720 Kbps Dn Actual Std. Mode: G_DMT Actual VPI/VCI: 0/35
 Actual SNR[up/dn] 6dB/6dB Delay[up/dn] 16ms/16ms Correction[up/dn] 1ms/1ms Interleave Depth[up/dn] 8/64 Las
 Update: 00:00:00:00

Standard Mode

MULTIMODE

MULTIMODE

T1_413

G_LITE

G_DMT

ALCTL

G_DMT_BIS

G_DMT_BISplus

READSL2

4.1.2.11 Submit

Click the *submit* button at the bottom of the Circuit Configuration window.

The screenshot displays the 'Circuit Configuration' window. At the top, there are navigation tabs: 'Circuit Config', 'DSCP & IP Rules', 'MAC Rules', 'VLAN Rules', 'Port Statistics', 'Port Copy', and 'SNR Advanced Config'. Below these is a table with columns: Slot, Port, Circuit Identification, Device Type, and Revision. The 'Slot' is set to 2 and 'Port' to 10. The 'Device Type' is AIM24000-48 and 'Revision' is 1.00.00.

The main configuration area is titled 'Circuit Configuration Settings'. It includes:

- Port Mode Setting:** Radio buttons for Fixed, Adaptive (selected), Fixed Adaptive, and OFF. A 'VPI/VCI Detect Setting' section with radio buttons for ON (selected) and OFF.
- Filter IP Address Settings:** Four rows for IP Range 1-4, each with two input fields. Range 1 has values 0.0.0.0 and 255.255.255.255. A 'Protocol Setting' section with radio buttons for All (selected) and Select, followed by four input fields for protocol values (all 0000).
- DHCP Option 82 Setting:** Radio buttons for Enabled and Disabled (selected). An 'Identifying String' dropdown menu with 'IPAddress:MIPII' selected.
- Layer 2 Port Filter Settings:** A checkbox for 'Layer 2 Port Filter Settings' (unchecked). A note: 'Note: If port is loop bonded, only configure the lowest numbered port in the group.' Three MAC address input fields (MAC 1, 2, 3) all containing 00.00.00.00.00.00. A checkbox for 'Unlimited # of MACs' (unchecked) and a 'Define # of MACs' input field with '0'.

At the bottom, there are dropdowns for 'VPI' (0), 'VCI' (0), 'Frame Type' (1483LLC), and 'Standard Mode' (MULTIMODE). A 'submit' button is centered below these. At the very bottom, a 'Port Status' section shows: Link: Adaptive 1024 Kbps Up, 10720 Kbps Dn; Actual Std. Mode: G_DMT; Actual VPI/VCI: 0/35; Actual SNR[up/dn]: 6dB/6dB; Delay[up/dn]: 16ms/16ms; Correction[up/dn]: 1ms/1ms; Interleave Depth[up/dn]: 8/64; Last Update: 00:00:00:00.

NOTE If you exit the Circuit Configuration window without first clicking *submit*, you will lose all configuration changes made in the Circuit Configuration window and all circuit parameters will remain configured as they were prior to your changes.

4.1.3 VLAN Rules

VLAN, Backbone-VLAN, Priority and Flood are all configured in conjunction with the Quality of Service (QoS) Rules in NMS. QoS Rules include Differentiated Services (Diffserv) Rules, Internet Protocol (IP) Range Rules and Medium Access Control (MAC) Range Rules, in addition to Virtual Local Area Network (VLAN) Rules. Refer to Net to Net's QoS Management User Guide at <http://www.nettonet.com/support/docs/210-0000055> for complete configuration instructions.

4.2 Via CLI

Command Line Interface (CLI) is a method of AIM24000 management that utilizes a set of commands and sub-commands/qualifiers via a Terminal Emulator program.

NOTE AIM24000 Ports 25-48 cannot currently be managed via CLI; only Ports 1-24 can be managed via CLI at present.

If your IP DSLAM is newly installed and has not yet been initialized, you must configure the IP Address, Subnet Mask and Gateway via a direct PC to DSLAM connection before you will be able to access data or complete any other configurations. If your IP DSLAM has already been initialized, you can manage the AIM24000 via either a direct PC to DSLAM connection or remotely via Telnet. Refer to Net to Net's CLI Management User Guide at <http://www.nettonet.com/support/docs/210-0000052> for instructions.

4.2.1 Log In

Launch a Terminal Emulator program on your PC. The following information will appear on your Terminal Emulator screen, followed by a request for username. You must log in as a Superuser in order to configure an AIM24000 port.

```
Net to Net Technologies [IP DSLAM model name]
Copyright (C) [year]
[management module model name] Version [firmware version]
System Build Date: [month] [day] [year], [hours:minutes:seconds]
Username:_
```

Once your username has been entered, you will be prompted for a password.

```
Username: xxxxxx
Password:_
```

NOTE Net to Net's default Superuser username is "superuser" and the default Superuser password is "Password" (both are case sensitive).
--

4.2.2 Circuit Configuration

A command prompt will appear once you have logged in. The CLI command prompt is tied to a user-defined DSLAM system name. The default system name is the model name of the DSLAM management module into which you are logged.

```
[system name] ->_
```

4.2.2.1 Circuit Identification

User Defined: up to 15 alpha-numeric characters
Default: n/a

```
[system name] ->SET SLOT [slot number of the AIM24000] PORT [port number]
CIRCUIT_ID [xxxxxxxxxxxxxxxxxx]
```

Example: [system name] ->set slot 2 port 10 circuit_id smith54321

4.2.2.2 Standard Mode

Options: Multimode, G.DMT, G.lite, T1.413, Alcatel
Default: Multimode

```
[system name] ->SET SLOT [slot number of the AIM24000] PORT [ALL or port
number] ADSL_STANDARD [MULTIMODE, G.DMT, G.LITE, T1.413, ALCATEL]
```

Example: [system name] ->set slot 2 port 10 adsl_standard multimode

4.2.2.3 Port Mode

Options: On (see note), Off, Adaptive, Fixed Adaptive
Default: Adaptive

NOTE Port Mode <i>on</i> in CLI is equivalent to Port Mode <i>fixed</i> in NMS and SNMP.

```
[system name] ->SET SLOT [slot number of the AIM24000] PORT [ALL or port
number] ADSL_PORT_MODE [on, off, adaptive, fixed_adaptive]
```

Example: [system name] ->set slot 2 port 10 adsl_port_mode fixed_adaptive

4.2.2.4 Speed

Downstream = xxxx (kbps)

Upstream = yyyy (kbps)

Default: n/a (Adaptive Port Mode)

[system name] ->SET SLOT [slot number of the AIM24000] PORT [ALL or port number] SPEED [xxxx] [yyyy]

Example: [system name] ->set slot 2 port 10 speed 1024 8064

4.2.2.5 IP Range

Proper Syntax: xxx.xxx.xxx.xxx

Value Range: 0-255 for each triple-digit quadrant

Default: 0.0.0.0 - 255.255.255.255

4.2.2.5.1 Single IP Address

Starting IP = Ending IP

[system name] ->SET SLOT [slot number of the AIM24000] PORT [ALL or port number] IP_RANGE [1 or 2] [xxx.xxx.xxx.xxx] [xxx.xxx.xxx.xxx]

Example: [system name] ->set slot 2 port 10 ip_range 1 193.166.254.98
193.166.254.98

4.2.2.5.2 IP Address Range

Starting IP < Ending IP

[system name] ->SET SLOT [slot number of the AIM24000] PORT [ALL or port number] IP_RANGE [1 or 2] [xxx.xxx.xxx.xxx] [xxx.xxx.xxx.xxx]

Example: [system name] ->set slot 2 port 10 ip_range 1 193.166.254.98
193.166.254.254

4.2.2.5.3 Full IP Address Range

Starting IP = 0.0.0.0

Ending IP = 255.255.255.255

[system name] ->SET SLOT [slot number of the AIM24000] PORT [ALL or port number] IP_RANGE [1 or 2] [xxx.xxx.xxx.xxx] [xxx.xxx.xxx.xxx]

Example: [system name] ->set slot 2 port 10 ip_range 1 0.0.0.0
255.255.255.255

4.2.2.6 VLAN Range

Value Range: 0 - 4085

Default: 0 (off)

Up to 10 VLAN Ranges may be configured per port; both start and end tags must be entered for ALL configured ranges, including single VLAN and VLAN off.

4.2.2.6.1 VLAN Off

Start VLAN Tag = 0

End VLAN Tag = 0

Only packets without a designated VLAN tag will be allowed to traverse the port.

[system name] ->SET SLOT [slot number of the AIM24000] PORT [ALL or port number] VLAN_RANGE [1-10] [0-0]

Example: [system name] ->set slot 2 port 10 vlan_range 1 0-0

INGRESS PACKETS FROM	WITH	WILL BE
WAN	no VLAN tag	transmitted
	any VLAN tag	dropped
uplink	no VLAN tag	transmitted
	any VLAN tag	dropped

4.2.2.6.2 Single VLAN

Value Range: 1-4085

Start VLAN Tag = End VLAN Tag

Any port configured with a single VLAN tag will automatically be designated as an IEEE 802.1Q VLAN Access Port; only packets with the specified VLAN tag will be allowed to traverse the port.

[system name] ->SET SLOT [slot number of the AIM24000] PORT [ALL or port number] VLAN_RANGE [1-10] [(1-4085)-(1-4085)]

Example: [system name] ->set slot 2 port 10 vlan_range 1 100-100

INGRESS PACKETS FROM	WITH	WILL BE
WAN	no VLAN tag	transmitted after the configured VLAN tag has been automatically added to the packet*
	any VLAN tag	dropped
uplink	no VLAN tag	dropped
	specified VLAN tag	transmitted after the VLAN tag has been automatically removed from the packet
	any VLAN tag other than the specified VLAN tag	dropped

NOTE When VLAN tags are added to a packet, VLAN ID and VLAN Priority will automatically be added in accordance with current configurations and a CFI bit will automatically be added as zero.

4.2.2.6.3 VLAN Range

Value Range: 1 - 4085

Start VLAN Tag < End VLAN Tag

A port set with one or more specified VLAN ranges will automatically be designated as an IEEE 802.1Q VLAN Trunk Port; only packets tagged within the specified VLAN range(s) will be allowed to traverse the port.

[system name] ->SET SLOT [slot number of the AIM24000] PORT [ALL or port number] VLAN_RANGE [1-10] [(1-4085)-(1-4085)]

Example: [system name] ->set slot 2 port 10 vlan_range 1 100-250

INGRESS PACKETS FROM	WITH	WILL BE
WAN	no VLAN tag	dropped
	a VLAN tag within the specified range	transmitted
	a VLAN tag outside of the specified range	dropped
uplink	no VLAN tag	dropped
	a VLAN tag within the specified range	transmitted
	a VLAN tag outside of the specified range	dropped

4.2.2.6.4 Full VLAN Range
 Start VLAN Tag = 1
 End VLAN Tag = 4085

A packet with any VLAN tag will be allowed to traverse the port.

[system name] ->SET SLOT [slot number of the AIM24000] PORT [ALL or port number] VLAN_RANGE [1-10] [1-4085]

Example: [system name] ->set slot 2 port 10 vlan_range 1 1-4085

INGRESS PACKETS FROM	WITH	WILL BE
WAN	no VLAN tag	dropped
	any VLAN tag	transmitted
uplink	no VLAN tag	dropped
	any VLAN tag	transmitted

4.2.2.7 Backbone-VLAN

Value Range: 0 - 4085

Default: 0 (off)

[system name] ->SET SLOT [slot number of the AIM24000] PORT [ALL or port number] BACKBONE_VLAN [0-4085]

Example: [system name] ->set slot 2 port 10 backbone_vlan 100

INGRESS PACKETS FROM	WITH	WILL BE
WAN	both Backbone-VLAN & VLAN tags	dropped, regardless of whether the Backbone-VLAN tag is in accordance with current VLAN configurations.
	standard VLAN tags only	transmitted in accordance with current VLAN configurations. If the packet adheres to the VLAN rules and Backbone-VLAN is currently configured, then a Backbone-VLAN tag will be added prior to packet transmission.
uplink	both Backbone-VLAN & VLAN tags	dropped, if Backbone-VLAN is not currently configured or if Backbone-VLAN is configured but the packet's Backbone-VLAN tag does not match the Backbone-VLAN configuration. If the packet's Backbone-VLAN tag DOES match the current configuration, the packet will be transmitted in accordance with current VLAN configurations.
	standard VLAN tags only	dropped, if Backbone-VLAN is currently configured. If Backbone-VLAN is NOT currently configured, then the packet will be transmitted in accordance with current VLAN configurations.

4.2.2.8 VLAN Priority

Value Range: 0 - 7

Default: 0 (no priority)

[system name] ->SET SLOT [slot number of the AIM24000] PORT [ALL or port number] PRIORITY [0-7]

Example: [system name] ->set slot 2 port 10 priority 3

IF PORT VLAN CONFIGURATION IS	THEN
VLAN 0	the priority configuration is irrelevant; the packet does not have VLAN tags.
Single VLAN	the configured priority will automatically be added to the VLAN tag (and Backbone-VLAN tag, if utilized).
VLAN Range	the existing priority in the VLAN tag (and Backbone-VLAN tag, if utilized) will automatically be replaced with the configured priority.

4.2.2.9 Protocol

Options: ALL or IP

Default: ALL

[system name] ->SET SLOT [slot number of the AIM24000] PORT [ALL or port number] Protocol [All or IP]

Example: [system name] ->set slot 2 port 10 protocol all

4.2.2.10 Flood

Options: Uplink (upl) or VLAN (vln)

Default: Uplink

[system name] ->SET SLOT [slot number of the AIM24000] PORT [ALL or port number] FLOOD [upl or vln]

Example: [system name] ->set slot 2 port 10 flood upl

4.2.2.11 Frame Type

Options: 1483LLC or 1483VCM

Default: 1483LLC

[system name] ->SET SLOT [slot number of the AIM24000] PORT [ALL or port number] ADSL_ENCAPSULATION [RFC1483-LLC or RFC1483-VCMUX]

Example: [system name] ->set slot 2 port 10 adsl_encapsulation rfc1483-llc

4.2.2.12 VPI/VCI Detect

Options: On or Off

Default: On

[system name] ->SET SLOT [slot number of the AIM24000] PORT [ALL or port number] ADSL_VPI_VCI_DETECT [ON or OFF]

Example: [system name] ->set slot 2 port 10 adsl_vpi_vci_detect on

4.2.2.12.1 VPI/VCI Manual Configuration

If you wish to manually configure VPI and VCI values, you must first configure VPI/VCI Detect to *off*.

4.2.2.12.1.1 VPI

Value Range: 0 - 7

[system name] ->SET SLOT [slot number of the AIM24000] PORT [ALL or port number] ADSL_VPI [0-255]

Example: [system name] ->set slot 2 port 10 adsl_vpi 0

4.2.2.12.1.2 VCI

Value Range: 0 - 255

[system name] ->SET SLOT [slot number of the AIM24000] PORT [ALL or port number] ADSL_VCI [0-65535]

Example: [system name] ->set slot 2 port 10 adsl_vci 35

4.3 Via SNMP

Simple Network Management Protocol (SNMP) is the standard for management of Transmission Control Protocol/Internet Protocol (TCP/IP) networks and network devices. SNMP management of an AIM24000 is accomplished with a Management Information Base (MIB) browser via a set of Object Identifiers (OIDs). OIDs are strings of numbers that specify various configuration commands and requests for data. If you have not yet downloaded the supported MIB-II OIDs from the Internet Engineering Task Force (IETF) web site and the enterprise MIB OIDs from Net to Net's website, you must do so before the AIM24000 (or any other interface modules in your IP DSLAM) will be configurable via SNMP. Once downloaded, the OIDs must then be compiled into your MIB browser. Usage and entry of OIDs and other qualifying data varies between MIB browser models; refer to your MIB browser user manual for compilation and usage instructions.

NOTE AIM24000 Ports 25-48 cannot currently be managed via CLI; only Ports 1-24 can be managed via CLI at present.

If your IP DSLAM is newly installed and has not yet been initialized, you must configure the IP Address, Subnet Mask and Gateway via either NMS or CLI before you will be able to utilize SNMP. See the NMS Management User Guide at <http://www.nettonet.com/support/docs/210-0000048> or the CLI Management User Guide at <http://www.nettonet.com/support/docs/210-0000052> for initialization instructions.

4.3.1 Contact your IP DSLAM

Open a MIB Browser on your PC, enter your IP DSLAM's IP address (as the remote SNMP agent) and *contact* the DSLAM.

4.3.2 Circuit Configuration

Net to Net's Access Module Configuration MIBs define the SNMP Application Programming Interface for parameter configuration of individual ports on the AIM24000. Select the OID correlating to the parameter you wish to configure, enter the *instance* to which you wish to apply the OID, and then *set* the OID. X, y and z define the *instances* for OIDs as specified in the table below.

NOTE The OID base for ALL Net to Net MIBs is 1.3.6.1.4.1.8059.

PARAMETER	OID (1.3.6.1.4.1.8059.+)	INPUT/RETURN VALUES	SYNTAX	ADDITIONAL INFORMATION
SLOT INDEX ifCfgSlotIndex	1.2.1.1.1.2.1.1.1.x.y	x=1-12 (Slot) y=1-48 (Port)	32-bit Integer	Input x and y; returns x
PORT INDEX ifCfgPortIndex	1.2.1.1.1.2.1.1.2.x.y	x=1-12 (Slot) y=1-48 (Port)	32-bit Integer	Input x and y; returns y
CIRCUIT ID ifCfgPortCircuitID	1.2.1.1.1.2.1.1.3.x.y	User Defined	0-15 Octet String	
START IP RANGE 1 ifCfgPortFltrIP1Start	1.2.1.1.1.2.1.1.4.x.y	User Defined	IP Address: -----	Default: 0.0.0.0 Value range for each triple-digit quadrant: 0-255

PARAMETER	OID (1.3.6.1.4.1.8059.+)	INPUT/RETURN VALUES	SYNTAX	ADDITIONAL INFORMATION
END IP RANGE 1 ifCfgPortFltrIP1End	1.2.1.1.1.2.1.1.5.x.y	User Defined	IP Address: -----	Default: 255.255.255.255 Value range for each triple-digit quadrant: 0-255
START IP RANGE 2 ifCfgPortFltrIP2Start	1.2.1.1.1.2.1.1.6.x.y	User Defined	IP Address: -----	Default: 0.0.0.0 Value range for each triple-digit quadrant: 0-255
END IP RANGE 2 ifCfgPortFltrIP2End	1.2.1.1.1.2.1.1.7.x.y	User Defined	IP Address: -----	Default: 0.0.0.0 Value range for each triple-digit quadrant: 0-255
BACKBONE-VLAN ifCfgPortBackboneVlan	1.2.1.1.1.2.1.1.8.x.y	0-4085	32-bit Integer	0=OFF (Default) Refer to Section 4.2.2.7 for configuration application details.
VLAN PRIORITY ifCfgPortVlanPriority	1.2.1.1.1.2.1.1.9.x.y	0-7	32-bit Integer	0=No Priority (Default) 1=Lowest Priority 7=Highest Priority Refer to Section 4.2.2.8 for configuration application details.
FLOOD ifCfgPortFloodMde	1.2.1.1.1.2.1.1.10.x.y	1, 2	32-bit Integer	1=Uplink (Default) 2=VLAN
PROTOCOL ifCfgPortIpFltProtocol	1.2.1.1.1.2.1.1.11.x.y	1, 2	32-bit Integer	1=ALL Traffic (Default) 2=TCP/IP/ARP traffic only
VLAN SLOT INDEX ifCfgIfSlotIndex	1.2.1.1.1.2.2.1.1.x.y.z	x=1-12 (Slot) y=1-48 (Port) z=1-10 (VLAN)	32-bit Integer	Input x,y and z; returns x
VLAN PORT INDEX ifCfgIfPortIndex	1.2.1.1.1.2.2.1.2.x.y.z	x=1-12 (Slot) y=1-48 (Port) z=1-10 (VLAN)	32-bit Integer	Input x,y and z; returns y
VLAN RANGE INDEX ifCfgVlanIndex	1.2.1.1.1.2.2.1.3.x.y.z	x=1-12 (Slot) y=1-48 (Port) z=1-10 (VLAN)	32-bit Integer	Input x,y and z; returns z Up to 10 VLAN Ranges may be specified per port.
VLAN START TAG ifCfgVlanIdStart	1.2.1.1.1.2.2.1.4.x.y.z	0-4085	32-bit Integer	Default=0 Refer to Section 4.2.2.6 for configuration application details.
VLAN END TAG ifCfgVlanIdEnd	1.2.1.1.1.2.2.1.5.x.y.z	0-4085	32-bit Integer	Default=0 Refer to Section 4.2.2.6 for configuration application details.
ADSL SLOT INDEX ifCfgAdslSlotIndex	1.2.1.1.1.2.3.1.1.x.y	x=1-12 (Slot) y=1-48 (Port)	32-bit Integer	Input x and y; returns x
ADSL PORT INDEX ifCfgAdslPortIndex	1.2.1.1.1.2.3.1.2.x.y	x=1-12 (Slot) y=1-48 (Port)	32-bit Integer	Input x and y; returns y
PORT MODE ifCfgAdslPortMode	1.2.1.1.1.2.3.1.3.x.y	1-3	32-bit Integer	1=Fixed 2=OFF 3=Adaptive (Default) An AIM24000 Port configured with Port Mode Fixed requires the additional configuration of upstream (ifCfgAdslTxRate) and downstream (ifCfgAdslRxRate) speeds.
VPI/VCI DETECT ifCfgAdslVpiVciDetect	1.2.1.1.1.2.3.1.4.x.y	1, 2	32-bit Integer	1=ON (Default) 2=OFF An AIM24000 port configured with VPI/VCI Detect OFF requires the configuration of VPI (ifCfgAdslVpi) and VCI (ifCfgAdslVci) values.
RX RATE ifCfgAdslRxRate	1.2.1.1.1.2.3.1.5.x.y	1-32	32-bit Integer	Upstream Speed = [1-32] x 32kbps = 32kbps - 1024kbps NOTE: A zero [0] returned via a GET command indicates that the port is in Adaptive Mode and is experiencing link-down.

PARAMETER	OID (1.3.6.1.4.1.8059.+)	INPUT/RETURN VALUES	SYNTAX	ADDITIONAL INFORMATION
TX RATE ifCfgAdslTxRate	1.2.1.1.1.2.3.1.6.x.y	1-252	32-bit Integer	Downstream Speed = [1-252] x 32kbps = 32kbps - 8064kbps NOTE: A zero [0] returned via a GET command indicates that the port is in Adaptive Mode and is experiencing link-down.
FRAME TYPE ifCfgAdslFrameType	1.2.1.1.1.2.3.1.7.x.y	1, 2	32-bit Integer	1=1438LLC (Default) 2=1438VCM
VPI ifCfgAdslVpi	1.2.1.1.1.2.3.1.8.x.y	0-7	32-bit Integer	Default=0
VCI ifCfgAdslVci	1.2.1.1.1.2.3.1.9.x.y	0-255	32-bit Integer	Default=35
STANDARD MODE ifCfgAdslStandardMode	1.2.1.1.1.2.3.1.10.x.y	1-5, 255	32-bit Integer	1=T1.413 2=G.lite 3=G.DMT 4=Multimode (Default) 5=Alcatel 255=No Link

5.0 ADDITIONAL INFORMATION

5.1 LED Indications

LED	STATE	INDICATION	ADDITIONAL INFORMATION
PWR (Power)	solid green	AIM24000 is receiving power	If the Power LED is not illuminated, it is unlikely the AIM24000 is receiving power, in which case none of the LEDs will be illuminated.
ADSL LK (Link)	solid green	ADSL connection is established	The ADSL link is operational.
	no illumination	no ADSL connection	The ADSL Rx and Tx LEDs will remain unlit by default.
ADSL Rx (Receiving)	flashing amber	ADSL activity	The port is receiving data from the remote ADSL modem.
	solid amber	heavy Rx traffic	The port is receiving large amounts of data from the remote ADSL modem.
	no illumination	no activity	A link may exist but the port is not receiving any data from the remote ADSL modem.
ADSL Tx (Transmitting)	flashing amber	ADSL activity	The port is transmitting data to the remote ADSL modem.
	solid amber	heavy Tx traffic	The port is transmitting large amounts of data to the remote ADSL modem.
	no illumination	no activity	A link may exist but the port is not transmitting any data to the remote ADSL modem.

5.2 DATA STORAGE

Configuration backup is inherent in the AIM24000. Upon initial power up of the host IP DSLAM, default parameters of the AIM24000 will remain in place unless changed through NMS, CLI or SNMP.

5.2.1 Memory

AIM24000 parameter configurations are automatically recorded in both the Random Access Memory (RAM) of the AIM24000 and the Non-Volatile Random Access Memory (NVRAM) of the IP DSLAM's management module.

5.2.1.1 RAM

Statistical data stored only in AIM24000 RAM, such as traffic statistics and link up/down time, will be erased if the module is removed from the IP DSLAM or the IP DSLAM loses power.

5.2.1.2 NVRAM

AIM24000 data stored in the IP DSLAM's management module NVRAM, such as port parameter configurations, will remain intact (even if the IP DSLAM loses power) unless deliberately cleared or reconfigured.

5.2.2 Local Files

5.2.2.1 Uploading a Port Template

AIM24000 port configurations can be flash uploaded from your IP DSLAM management module TO a file on your PC or local network via a Trivial File Transfer Protocol (TFTP) tool and a *get* command. A port template file contains all of a selected port's configurations EXCEPT Circuit ID.

ITEM	DATA NEEDED FOR BACKUP	EXAMPLE
Host Name	DSLAM IP Address (xxx.xxx.xxx.xxx)	193.166.254.98
Remote Filename	Nvr_PortCfg.Bin."Superuser password".[slot][port]	nvr_portcfg.bin.Password.[2][10]
Local Filename	User Preference	Adsl_ServiceLevel_4_template.bin

5.2.2.2 Downloading a Port Template

AIM24000 configuration files can also be flash downloaded FROM a local file TO your IP DSLAM's management module via a TFTP tool, simply replace the *get* command with a *put* command. A previously saved port configuration file can be applied to multiple ports on your AIM24000 simultaneously, via your IP DSLAM management module, by entering the port value [*ports*] as follows:

METHOD OF ENTRY	EXAMPLE: nvr_portcfg.bin.Password.[slot][ports]
comma-separated list	nvr_portcfg.bin.Password.[2][10,12,20,45,]
dash-indicated range	nvr_portcfg.bin.Password.[2][10-45]
keyword "all"	nvr_portcfg.bin.Password.[2][all]

NOTE Refer to your TFTP user manual for further instruction.

5.3 Firmware Upgrades

NOTE Net to Net strongly recommends creating an IP DSLAM back-up file prior to downloading any new firmware revisions. Refer to Net to Net's Firmware Upgrade Procedure at <http://www.nettonet.com/support/docs/230-0000032> for instructions.

All customers registered with Net to Net's website (<http://www.nettonet.com/register>) will automatically receive notification of new firmware versions and accompanying documentation. New firmware versions can be downloaded from

<http://www.nettonet.com/support/downloads> via a Trivial File Transfer Protocol (TFTP) tool. Refer to Net to Net's Firmware Upgrade Procedure at <http://www.nettonet.com/support/docs/230-0000032> for instructions.

5.4 Regulatory Compliance for Class A Equipment

NOTE The following regulatory information applies to the AIM24000 as installed in a Net to Net IP DSLAM.

NEBS: GR-63-CORE, GR-1089-CORE

EMC: FCC Part 15; CSA/C108.8; EN55022, EN55024

SAFETY: UL 60950-1 1st Edition, UL Marking; CSA 22.2 No. 60950-1-03; EN60950-1:2001, CE Marking

TELECOM: ACTA968 (Part68); ICCS-03; TBR12 and TBR13

5.4.1 US Federal Communications Commission (FCC)

Note: This equipment has been tested and found to comply with the limits for a Class A digital device, pursuant to part 15 of the FCC Rules. These limits are designed to provide reasonable protection against harmful interference when the equipment is operated in a commercial environment. This equipment generates, uses and can radiate radio frequency energy and, if not installed and used in accordance with the instruction manual, may cause harmful interference to radio communications. Operation of this equipment in a residential area is likely to cause harmful interference in which case the user will be required to correct the interference at his own expense.

Caution: Changes or modifications not expressly approved by the manufacturer could void the user's authority to operate the equipment.

5.4.2 Industry Canada

This Class A digital apparatus complies with Canadian ICES-003.

Cet appareil numérique de la Classe A est conforme à la norme NMB-003 du Canada.

5.4.3 Europe

This Class A product complies with European Norm EN55022.

Warning: In a domestic environment this product may cause radio interference in which case the user may be required to take adequate measures to correct the situation.

© Copyright 2004 Net to Net Technologies, Inc.

™ The Net to Net Logo is a trademark of Net to Net Technologies, Inc.

Worldwide Headquarters

Net to Net Technologies
112 Corporate Drive
Portsmouth, NH 03801
USA
+1 877-638-2638
support@nettonet.com

<http://www.NetToNet.com/>

EMEA Headquarters

Net to Net Technologies
Victoria House 19 Park Way
Newbury Berkshire RG14 1EE
UK
+44 (0) 1635 570950
support-emea@nettonet.com